

# Housing - HC-B 24-TMB-100/O1STM32S-EUA - 1604557

Please be informed that the data shown in this PDF Document is generated from our Online Catalog. Please find the complete data in the user's documentation. Our General Terms of Use for Downloads are valid (<http://download.phoenixcontact.com>)



HEAVYCON ADVANCE for increased environmental requirements, sleeve housing B24, with bayonet locking, height 100 mm, with 1xM32 thread, lateral cable outlet



## Key commercial data

package_quantity	10
GTIN	4017918948238

## Technical data

### Dimensions

Height	100 mm
Width	57 mm
Length	152 mm
Length of the assembly cutout	112 mm
Width of the assembly cutout	35 mm

### Ambient conditions

Degree of protection for housing	IP65
Degree of protection for housing	IP67
Ambient temperature (operation)	-40 °C ... 200 °C

### General

Note	For contact inserts HC-B24, BB46, D64, DD108, HV10/16, M
Design	B24
Housing type	Sleeve housings
Locking type	Bayonet locking
No. of cable exits	1
Cable exit	Lateral
Screw connection	None
Type of the screw connection	1x M32
Housing material	Die-cast aluminum, salt water resistant
Housing surface material	Powder-coated, black
Seal material	Viton

# Housing - HC-B 24-TMB-100/O1STM32S-EUA - 1604557

## Technical data

### General

<b>Material lock</b>	High-grade steel
<b>Material grip body interlock</b>	PA-GF
<b>Assembly instructions</b>	In order to guarantee that the ground conductor contact functions even when plugged in at an angle, the two panel mounting flanges must have sufficient electrical contact with the metal mounting panel.

## classifications

### eCl@ss

<b>eCl@ss 4.0</b>	272607xx
<b>eCl@ss 4.1</b>	27260701
<b>eCl@ss 5.0</b>	27143424
<b>eCl@ss 5.1</b>	27143424
<b>eCl@ss 6.0</b>	27371205
<b>eCl@ss 7.0</b>	27371205
<b>eCl@ss 8.0</b>	27371205

### ETIM

<b>ETIM 2.0</b>	EC000437
<b>ETIM 3.0</b>	EC000437
<b>ETIM 4.0</b>	EC000437
<b>ETIM 5.0</b>	EC000437

### UNSPSC

<b>UNSPSC 6.01</b>	31261502
<b>UNSPSC 7.0901</b>	31261502
<b>UNSPSC 11</b>	31261502
<b>UNSPSC 12.01</b>	31261502
<b>UNSPSC 13.2</b>	31261502

## accessories

### Panel mounting flange

HC-B-BF - 1604641



# Housing - HC-B 24-TMB-100/O1STM32S-EUA - 1604557

## accessories

HC-B-BF-SET - 1604654



---

## Protective cover

HC-B 24-TMB-SD-IP65 - 1690969



---

## Full screw connection

HC-K-KV-M32(15-21) - 1690642



---

HC-M-KV-M32(14-21) - 1690587



---

HC-M-KV-M32(19-27) - 1646010



---

## Drawings

# Housing - HC-B 24-TMB-100/O1STM32S-EUA - 1604557

Dimensioned drawing

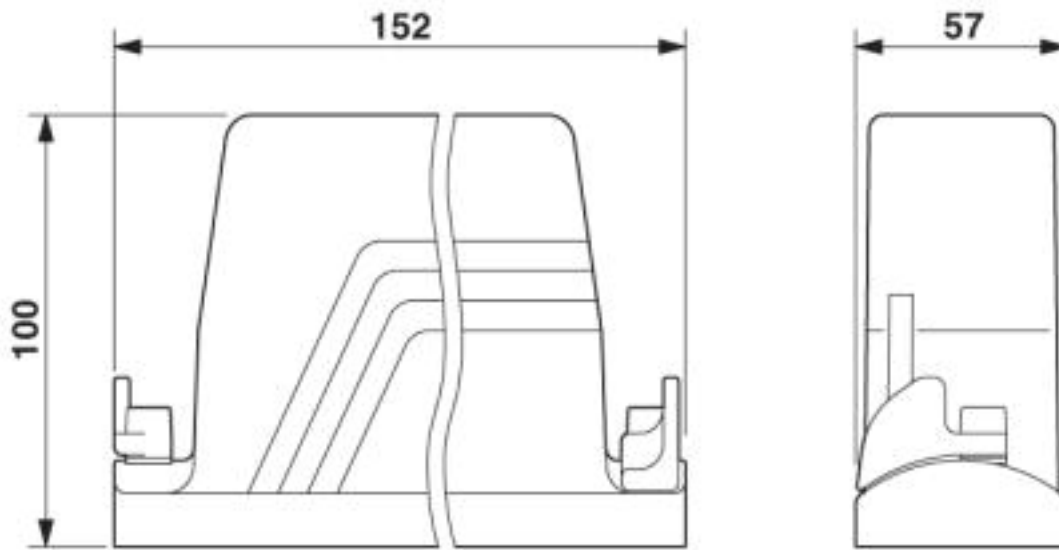

Dimensioned drawing

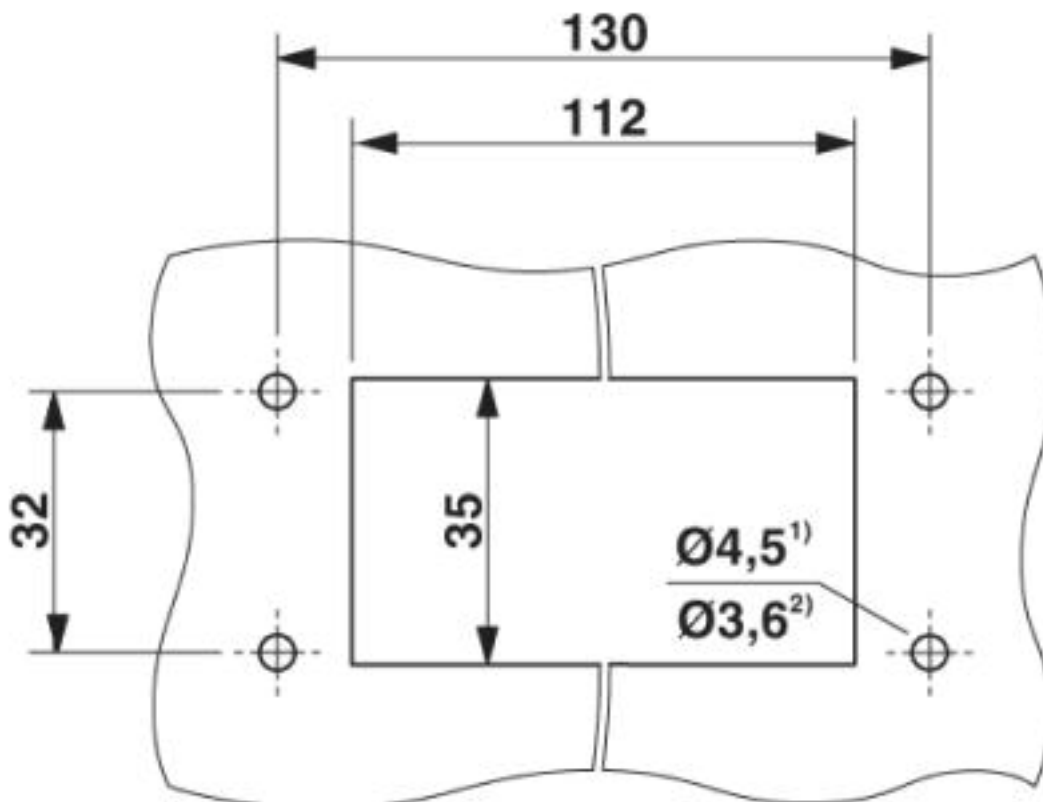

Panel cutout<sup>2)</sup> When self-tapping screws are used (Torx® 20, M4)

