

Interface module - FLKM-D37 SUB/B/LA - 2281704

Please be informed that the data shown in this PDF Document is generated from our Online Catalog. Please find the complete data in the user's documentation. Our General Terms of Use for Downloads are valid (<http://download.phoenixcontact.com>)



VARIOFACE module, with screw connection and D-Subminiature socket strip, for mounting on NS 35/7.5 or NS 32, with light indicator, 37-pos.



Key commercial data

package_quantity	1
GTIN	4017918054953

Technical data

Dimensions

Width	112.5 mm
Height	77 mm
Depth	58.5 mm

Ambient conditions

Ambient temperature (operation)	-20 °C ... 50 °C
Ambient temperature (storage/transport)	-20 °C ... 70 °C

General

Nominal voltage U_N	24 V DC
Max. current carrying capacity per branch	2.5 A
Number of positions	37
Status display	LED
Test voltage	500 V (50 Hz, 1 min.)
Mounting position	Any
Standards/regulations	IEC 60664
Standards/regulations	DIN EN 50178
Standards/regulations	IEC 62103
Pollution degree	2
Surge voltage category	II

Connection data for connection 1

Connection name	PCB connection
Connection in acc. with standard	IEC / EN

Interface module - FLKM-D37 SUB/B/LA - 2281704

Technical data

Connection data for connection 1

Connection method	Screw connection
Conductor cross section solid min.	0.2 mm ²
Conductor cross section solid max.	4 mm ²
Conductor cross section stranded min.	0.2 mm ²
Conductor cross section stranded max.	2.5 mm ²
Conductor cross section AWG/kcmil min.	24
Conductor cross section AWG/kcmil max	12
Stripping length	8 mm
Screw thread	M3

classifications

eCl@ss

eCl@ss 4.0	27250313
eCl@ss 4.1	27250313
eCl@ss 5.0	27250313
eCl@ss 5.1	27250313
eCl@ss 6.0	27242608
eCl@ss 7.0	27141152
eCl@ss 8.0	27141152

ETIM

ETIM 2.0	EC001434
ETIM 3.0	EC001604
ETIM 4.0	EC001604
ETIM 5.0	EC002780

UNSPSC

UNSPSC 6.01	30211824
UNSPSC 7.0901	39121421
UNSPSC 11	39121421
UNSPSC 12.01	39121421
UNSPSC 13.2	39121421

approvals

GOST /

Approval details



Interface module - FLKM-D37 SUB/B/LA - 2281704

accessories

System cable

CABLE-D37SUB/B/S/ 50/KONFEK/S - 2302191



CABLE-D37SUB/B/S/100/KONFEK/S - 2302201



CABLE-D37SUB/B/S/150/KONFEK/S - 2302214



CABLE-D37SUB/B/S/200/KONFEK/S - 2302227



CABLE-D37SUB/B/S/300/KONFEK/S - 2302230



Interface module - FLKM-D37 SUB/B/LA - 2281704

accessories

CABLE-D37SUB/B/S/400/KONFEK/S - 2302243



CABLE-D37SUB/B/S/600/KONFEK/S - 2302256



CABLE D-SUB-S/.../.../... - 2302340



CABLE D-SUB-S-S-S/.../.../... - 2302434



CABLE-D-37SUB/M/OE/0,25/S/0,5M - 2926577



CABLE-D-37SUB/M/OE/0,25/S/1,0M - 2926580



Interface module - FLKM-D37 SUB/B/LA - 2281704

accessories

CABLE-D-37SUB/M/OE/0,25/S/1,5M - 2926593



CABLE-D-37SUB/M/OE/0,25/S/2,0M - 2926603



CABLE-D-37SUB/M/OE/0,25/S/3,0M - 2926616



CABLE-D-37SUB/M/OE/0,25/S/4,0M - 2926629



CABLE-D-37SUB/M/OE/0,25/S/6,0M - 2926632



Interface module - FLKM-D37 SUB/B/LA - 2281704

accessories

CABLE-D-37SUB-M-OE-0,25-S/... - 2900912



Drawings

Circuit diagram

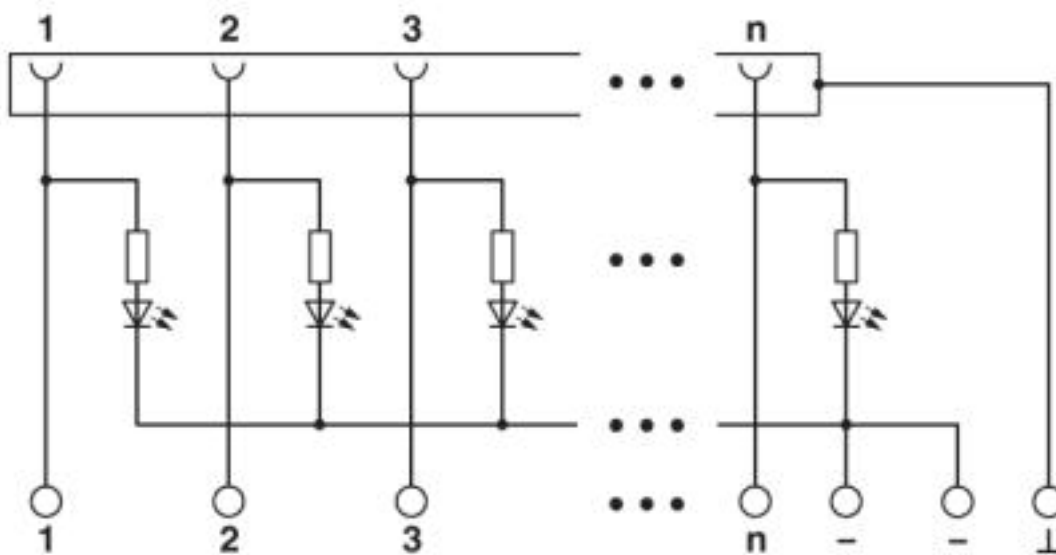

Interface module - FLKM-D37 SUB/B/LA - 2281704

Schematic diagram

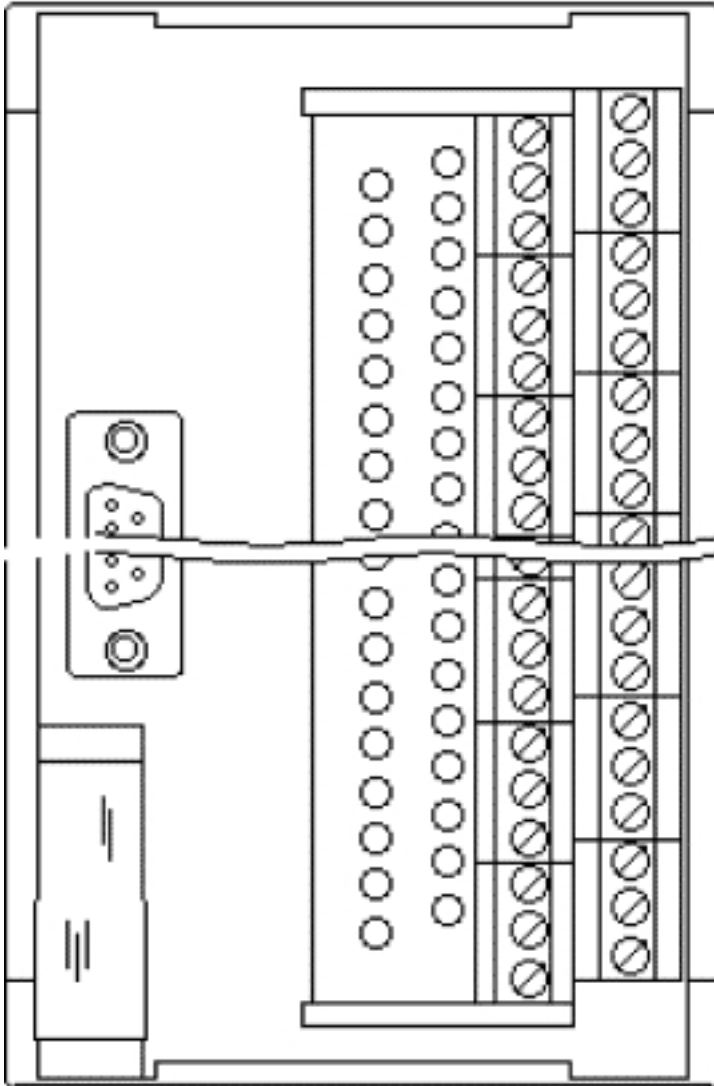

© Phoenix Contact 2013 - all rights reserved
<http://www.phoenixcontact.com>