

D-SUB sleeve housings - VS-09-T-2M16 - 1688353

Please be informed that the data shown in this PDF Document is generated from our Online Catalog. Please find the complete data in the user's documentation. Our General Terms of Use for Downloads are valid (<http://download.phoenixcontact.com>)



D-SUB sleeve housing, shell size 1, IP67 degree of protection

Key commercial data

| | |
|-------------------------|---------------|
| package_quantity | 5 |
| GTIN | 4017918817503 |

Technical data

Mechanical characteristics

| | |
|------------------------------------|---------------|
| Insertion/withdrawal cycles | ≥ 1000 |
| External cable diameter | 3 mm ... 9 mm |
| Cable exit | Angled |
| Color | gray |

Ambient conditions

| | |
|--|------------------|
| Ambient temperature (operation) | -40 °C ... 80 °C |
| Degree of protection | IP67 |

Material data

| | |
|--|----|
| Inflammability class according to UL 94 | V0 |
| Housing material | PA |

classifications

eCl@ss

| | |
|-------------------|----------|
| eCl@ss 4.0 | 27140816 |
| eCl@ss 4.1 | 27260701 |
| eCl@ss 5.0 | 27260701 |
| eCl@ss 5.1 | 27260701 |
| eCl@ss 6.0 | 27261203 |
| eCl@ss 7.0 | 27440202 |
| eCl@ss 8.0 | 27440202 |

ETIM

| | |
|-----------------|----------|
| ETIM 2.0 | EC000437 |
| ETIM 3.0 | EC000437 |

D-SUB sleeve housings - VS-09-T-2M16 - 1688353

classifications

ETIM

| | |
|----------|----------|
| ETIM 4.0 | EC000437 |
| ETIM 5.0 | EC000437 |

UNSPSC

| | |
|---------------|----------|
| UNSPSC 6.01 | 31261501 |
| UNSPSC 7.0901 | 31261501 |
| UNSPSC 11 | 31261501 |
| UNSPSC 12.01 | 31261501 |
| UNSPSC 13.2 | 31261501 |

accessories

Pressure nut

VS-M16 (3-6) - 1688450



VS-M16 (5-9) - 1688447



Protective cap

Q-PROT 9/11 - 1670235



Data plug

D-SUB sleeve housings - VS-09-T-2M16 - 1688353

accessories

VS-09-TI-2EMV - 1688476



Coding element

CP-HCC 4 - 1600027



Device marking

ZBN 18:UNBEDRUCKT - 2809128



Drawings

D-SUB sleeve housings - VS-09-T-2M16 - 1688353

Dimensioned drawing

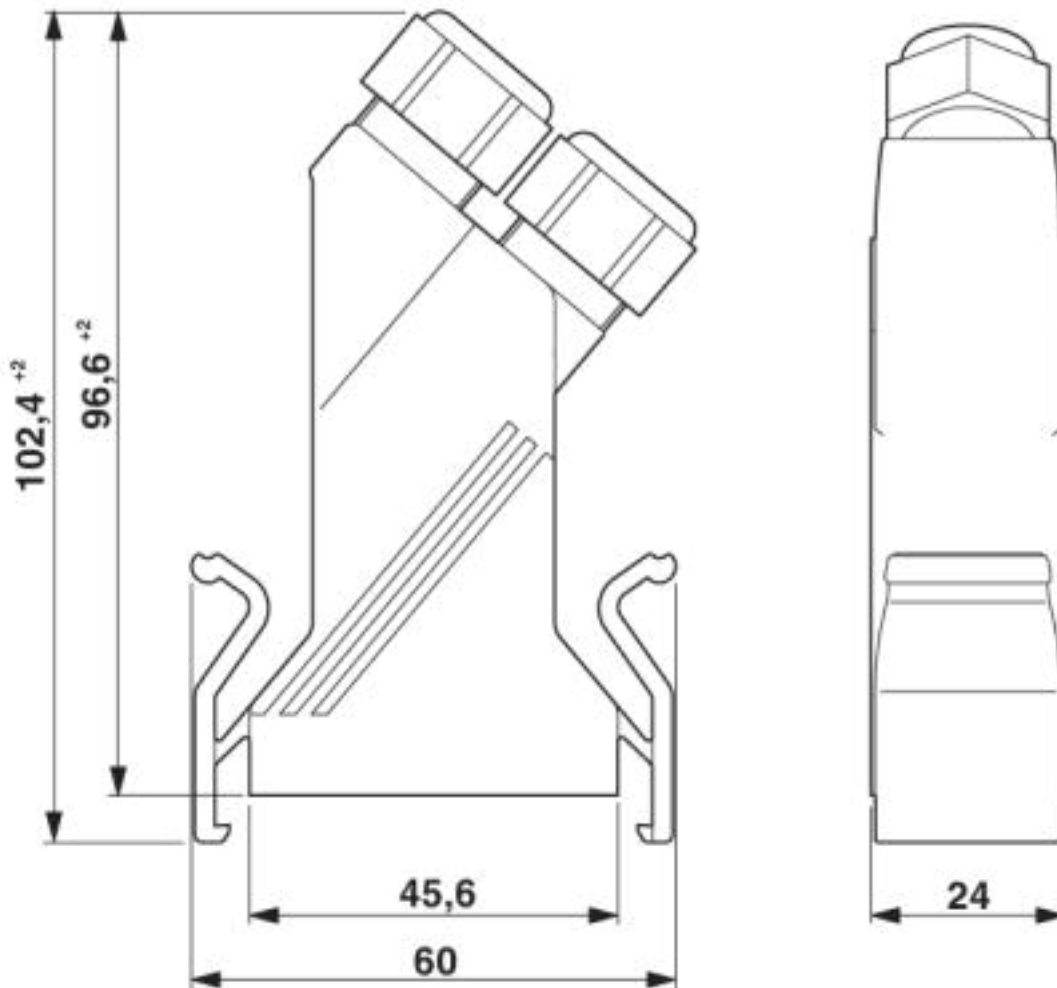

D-SUB sleeve housings

© Phoenix Contact 2013 - all rights reserved
<http://www.phoenixcontact.com>