

EMC housing - HC-B 16-TMB-100/O1STM40G-EMV - 1604450

Please be informed that the data shown in this PDF Document is generated from our Online Catalog. Please find the complete data in the user's documentation. Our General Terms of Use for Downloads are valid (<http://download.phoenixcontact.com>)



HEAVYCON ADVANCE EMV sleeve housing B16, with bayonet locking, height 100 mm, with 1x M40 thread, straight cable outlet

Key commercial data

package_quantity	10
GTIN	4017918948139

Technical data

Dimensions

Height	100 mm
Width	57 mm
Length	126 mm
Length of the assembly cutout	86 mm
Width of the assembly cutout	35 mm

Ambient conditions

Degree of protection for housing	IP65
Degree of protection for housing	IP67
Ambient temperature (operation)	-40 °C ... 125 °C

General

Note	For contact inserts HC-B16, BB32, D40, DD72, HS6, HV6, M, K
Design	B16
Housing type	Sleeve housings
Locking type	Bayonet locking
Cable exit	Straight
Screw connection	None
Type of the screw connection	1x M40
Housing material	Aluminum die-cast
Housing surface material	EMC coating, silver
Seal material	NBR, conductive
Material lock	High-grade steel
Material grip body interlock	PA-GF
Assembly instructions	In order to guarantee that the ground conductor contact functions even when plugged in at an angle, the two panel mounting flanges

EMC housing - HC-B 16-TMB-100/O1STM40G-EMV - 1604450

Technical data

General

	must have sufficient electrical contact with the metal mounting panel.
Connection	If insulating powder coating is present on the control cabinet panel, it should be removed from the profile gasket area in order to ensure optimum shielding.

classifications

eCl@ss

eCl@ss 4.0	272607xx
eCl@ss 4.1	27260701
eCl@ss 5.0	27143424
eCl@ss 5.1	27143424
eCl@ss 6.0	27371205
eCl@ss 7.0	27371205
eCl@ss 8.0	27371205

ETIM

ETIM 2.0	EC000437
ETIM 3.0	EC000437
ETIM 4.0	EC000437
ETIM 5.0	EC000437

UNSPSC

UNSPSC 6.01	31261502
UNSPSC 7.0901	31261502
UNSPSC 11	31261502
UNSPSC 12.01	31261502
UNSPSC 13.2	31261502

accessories

Panel mounting flange

HC-B-BF - 1604641



EMC housing - HC-B 16-TMB-100/O1STM40G-EMV - 1604450

accessories

HC-B-BF-SET - 1604654



Protective cover

HC-B 16-TMB-SD-IP65 - 1690956



Full screw connection

HC-EMV-KV-M40(19-28) - 1690545



Drawings

EMC housing - HC-B 16-TMB-100/O1STM40G-EMV - 1604450

Dimensioned drawing

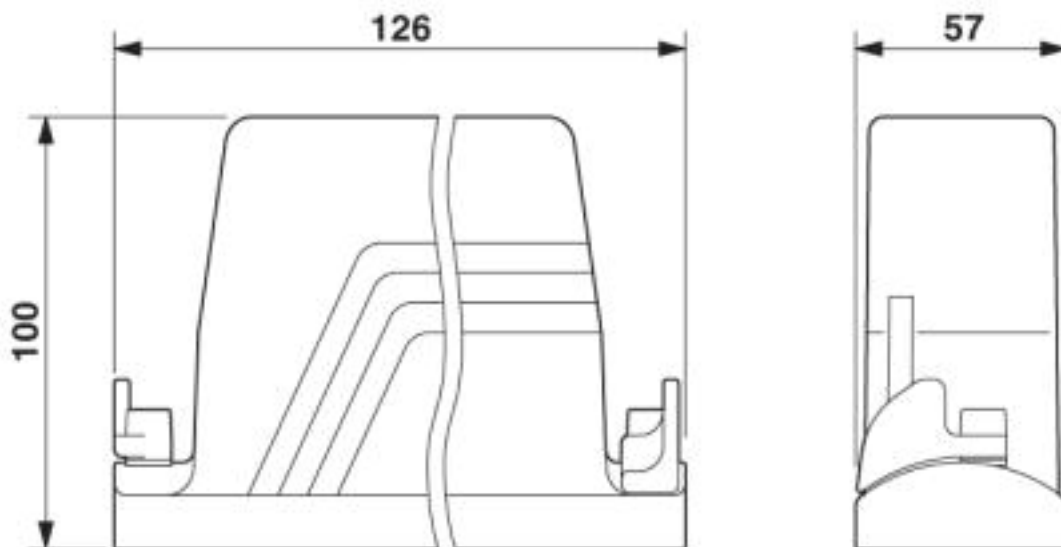

Dimensioned drawing

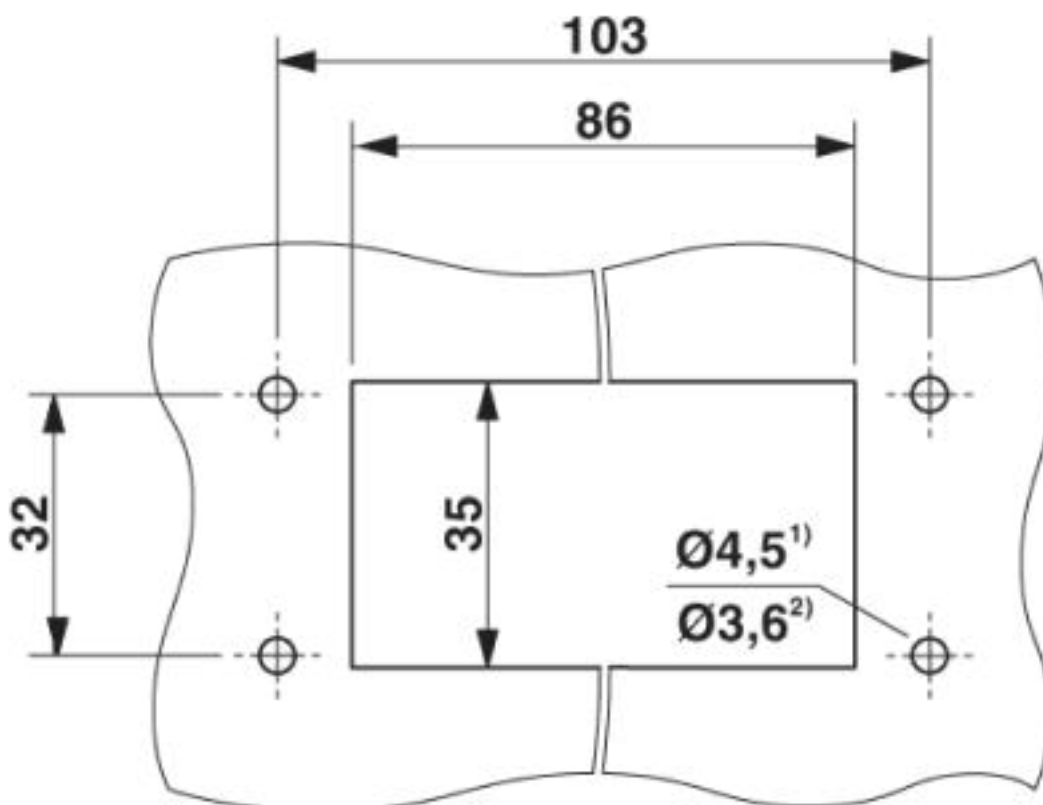

Panel cutout²⁾ When self-tapping screws are used (Torx® 20, M4)

