

Electronic housing - EG 45-G/ABS GN - 2764140

Please be informed that the data shown in this PDF Document is generated from our Online Catalog. Please find the complete data in the user's documentation. Our General Terms of Use for Downloads are valid (<http://download.phoenixcontact.com>)



Lower housing part, with snap-on foot

Illustration shows a fully mounted version of the electronic housing

Product Features

- Tool-free mounting
- Practical and easy-to-wire conductor connection using extra finely stranded sturdy screw terminal blocks up to 2.5 mm²
- Date of manufacture and material and part identification embossed on the housing (recyclability)
- Fast snap-on mounting on symmetrical DIN rails according to EN 60715
- Optimum accommodation of electronic components with graded pitches with a design width of 22.5 mm, 45 mm, 67.5 mm, and 90 mm
- Functional and industry-oriented housing technology
- Shock and contamination-proof accommodation of electronic components (IP40 housing, IP20 terminal blocks)

Key commercial data

| | |
|-------------------------|---------------|
| package_quantity | 10 |
| GTIN | 4017918065850 |

Technical data

General

| | |
|-------------------------|-------------------------------|
| Housing type | Component housing |
| Housing material | Acryl butadiene styrene (ABS) |
| Color | green |

Ambient conditions

| | |
|--|------------------|
| Ambient temperature (operation) | -40 °C ... 80 °C |
|--|------------------|

Dimensions

| | |
|------------------------------|----------|
| Length | 75 mm |
| Constructional height | 107.5 mm |
| Width | 45 mm |

Technical data

| | |
|--|-------------|
| Inflammability class according to UL 94 | HB |
| Power dissipation at 20°C in the horizontal mounting position | 3.4 W 6.1 W |
| Number of positions | 16 |

Electronic housing - EG 45-G/ABS GN - 2764140

classifications

eCl@ss

| | |
|------------|----------|
| eCl@ss 4.0 | 27180401 |
| eCl@ss 4.1 | 27180401 |
| eCl@ss 5.0 | 27180506 |
| eCl@ss 5.1 | 27180506 |
| eCl@ss 6.0 | 27180802 |
| eCl@ss 7.0 | 27182702 |
| eCl@ss 8.0 | 27182702 |

ETIM

| | |
|----------|----------|
| ETIM 2.0 | EC001031 |
| ETIM 3.0 | EC001031 |
| ETIM 4.0 | EC001031 |
| ETIM 5.0 | EC001031 |

UNSPSC

| | |
|---------------|----------|
| UNSPSC 6.01 | 31261501 |
| UNSPSC 7.0901 | 31261501 |
| UNSPSC 11 | 31261501 |
| UNSPSC 12.01 | 31261501 |
| UNSPSC 13.2 | 31261501 |

approvals

UL Recognized /

Approval details



accessories

Coding element

CR-MSTB - 1734401



Electronic housing - EG 45-G/ABS GN - 2764140

accessories

CP-MSTB - 1734634



CR-MSTB - 1734401



CP-MSTB - 1734634



Printed circuit board housing

MSTBO 2,5/ 8-GL-5,08 - 1850495



PCB plug

MVSTBW 2,5/ 8-ST - 1792582



Electronic housing - EG 45-G/ABS GN - 2764140

accessories

MVSTBW 2,5/ 8-ST-5,08 - 1792812



MVSTBW 2,5/ 8-STEH - 1784309

FKCT 2,5/ 8-ST - 1909278



FKCT 2,5/ 8-ST-5,08 - 1902178



Printed circuit board terminal

MKKDSH 3/ 2 - 1721045



Electronic housing - EG 45-G/ABS GN - 2764140

accessories

MKKDSH 3/ 3 - 1721346



MKKDSH 3/ 8 - 1703283

Drawings

Electronic housing - EG 45-G/ABS GN - 2764140

Explosion drawing

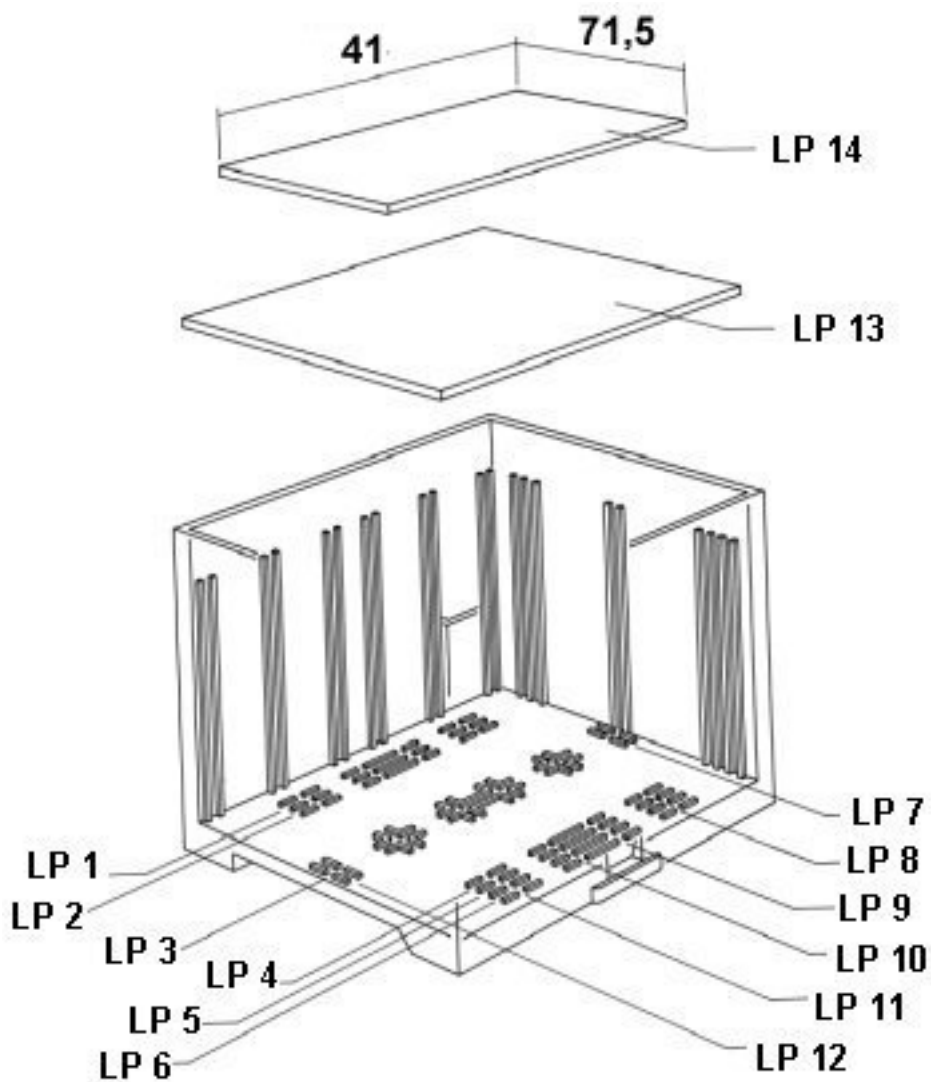

valid for PCB 13

Electronic housing - EG 45-G/ABS GN - 2764140

Explosion drawing

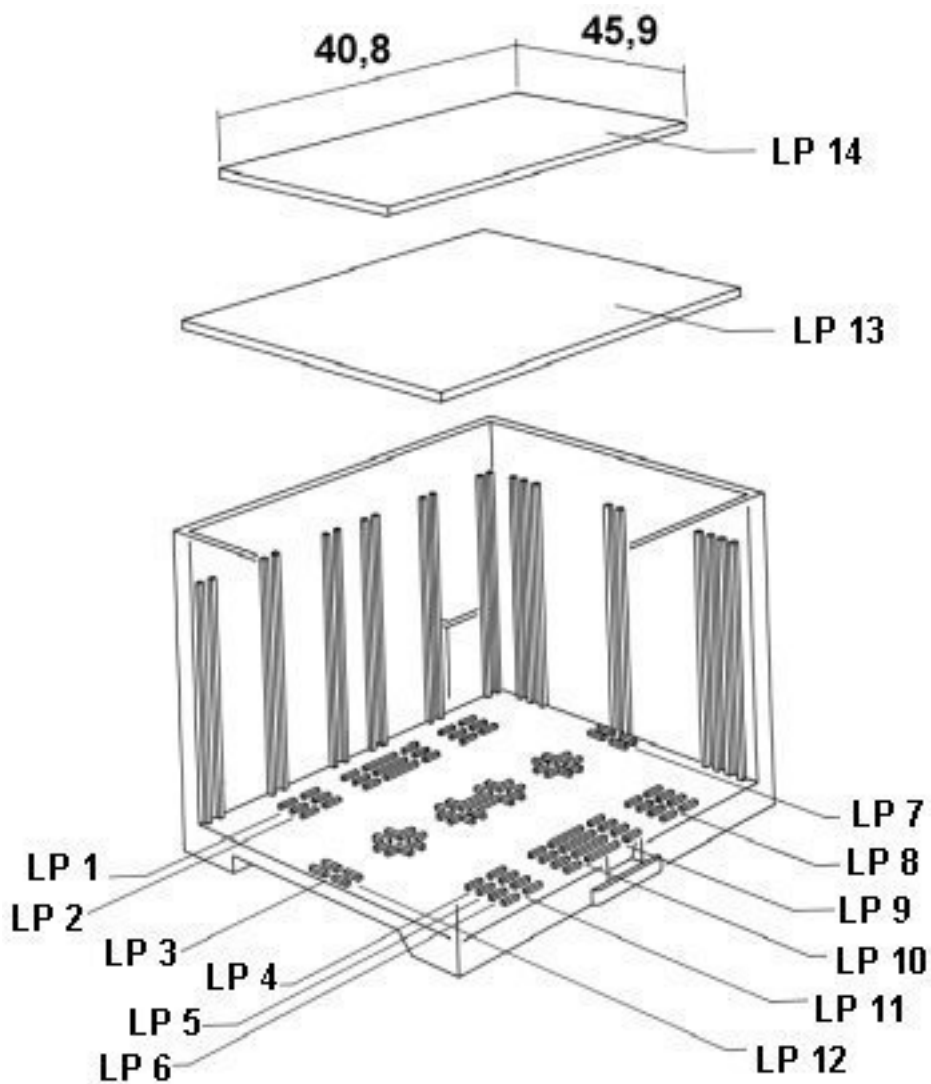

valid for PCB 14

Electronic housing - EG 45-G/ABS GN - 2764140

Dimensioned drawing

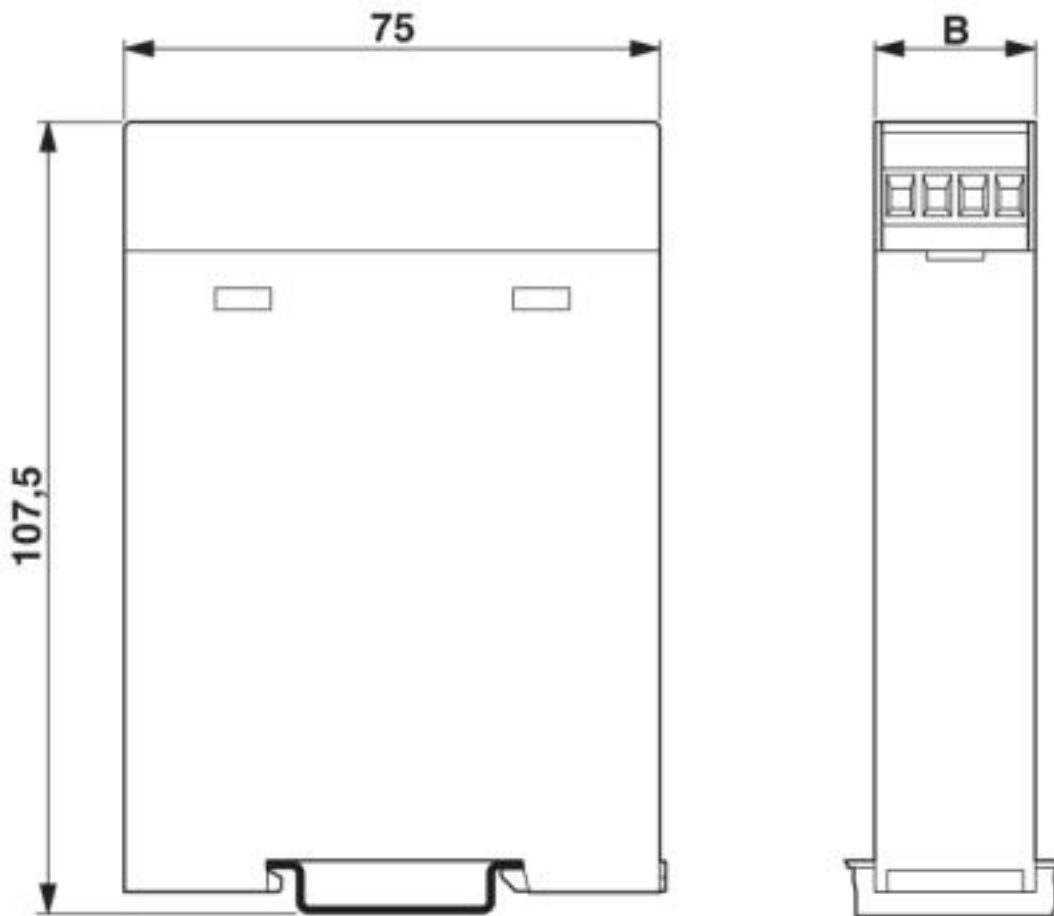

Electronic housing - EG 45-G/ABS GN - 2764140

Dimensioned drawing

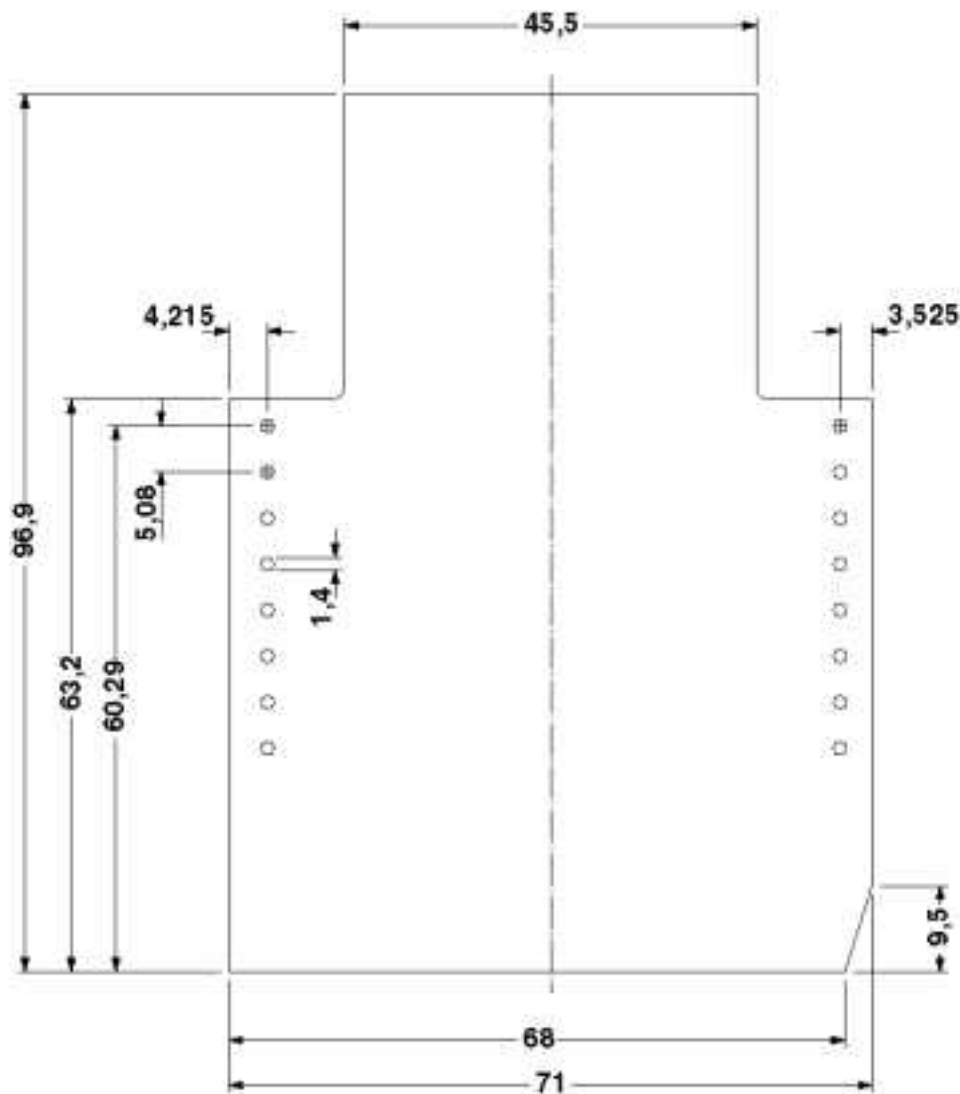

Component mounting side, if the double-level upper part is used

Electronic housing - EG 45-G/ABS GN - 2764140

Dimensioned drawing

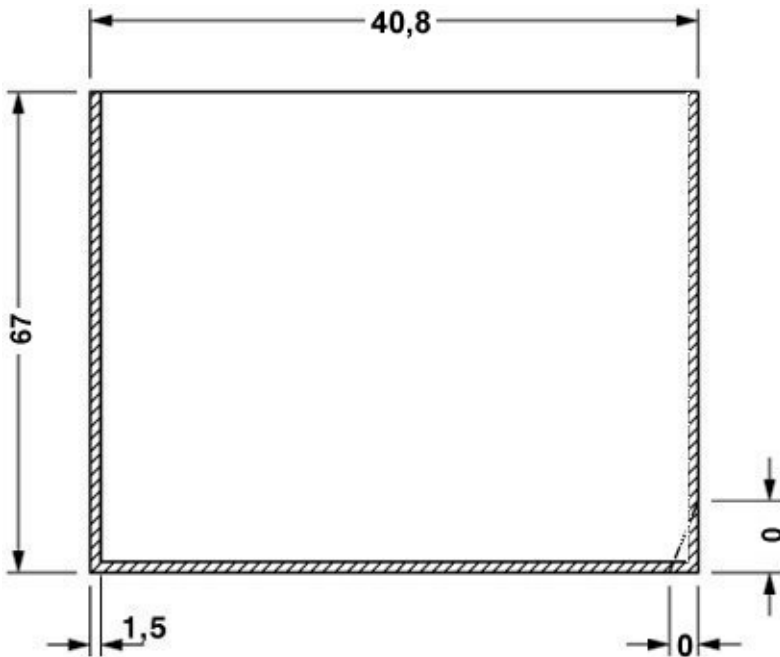

valid for PCB 1; 3; 5 and 6, see explosion drawing

Dimensioned drawing

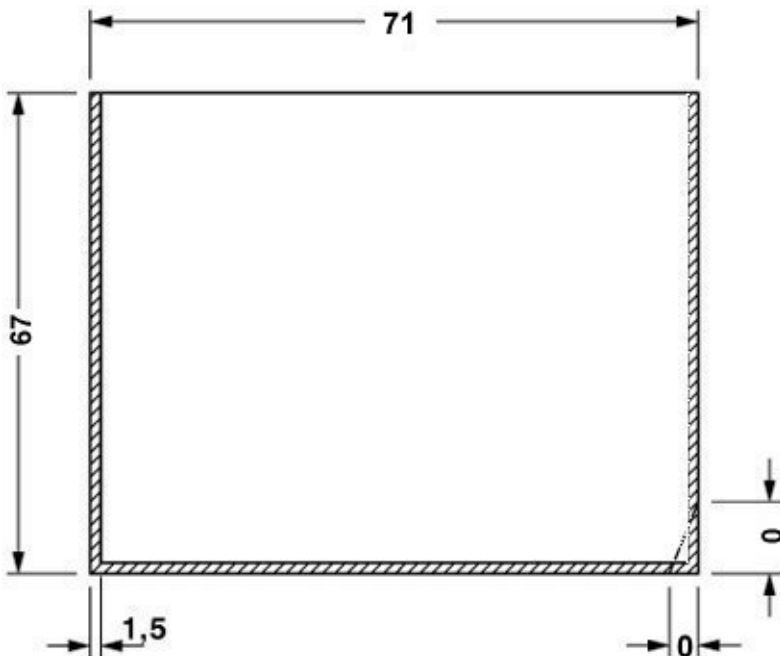

valid for PCB 7 and 12, see explosion drawing

Electronic housing - EG 45-G/ABS GN - 2764140

Dimensioned drawing

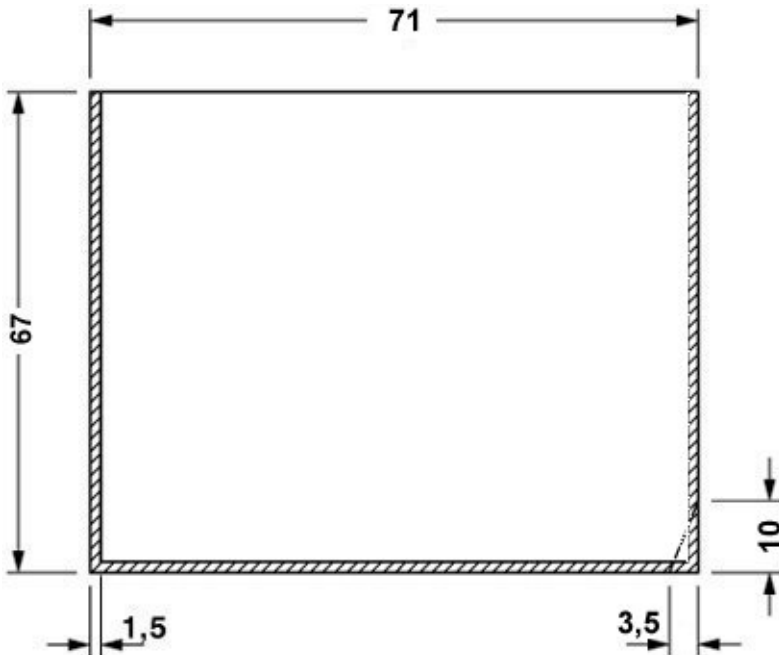

valid for PCB 10, see explosion drawing

© Phoenix Contact 2013 - all rights reserved
<http://www.phoenixcontact.com>