

ASSEMBLY INSTRUCTIONS:

1. PREPARE CABLE AS REQUIRED TO ASSEMBLE TO THE CONNECTOR
2. CHOOSE THE STRAIN RELIEF HALVES THAT MOST CLOSELY MATCH THE CABLE DIAMETER. THEY DO NOT NEED TO BE MATCHING HALVES.
3. IF USING SHIELD WIRE - PLACE THE SHIELD WIRE THROUGH THE HOLE IN ONE SIDE OF STRAIN RELIEF HALF (FIG.1). APPLY THE OTHER STRAIN RELIEF HALF ON TOP OF CABLE JACKET AND WRAP THE SHIELD WIRE AROUND BOTH STRAIN RELIEF HALVES AS SHOWN IN FIG.2
4. IF USING BRAID SHIELD - PIGTAIL THE SHIELD AND POSITION IN STRAIN RELIEF AS SHOWN IN FIG. 3. TRIM EXCESS BRAID.
5. PLACE THE STRAIN RELIEF/SHIELD SUPPORT INTO THE APPROPRIATE RECESS IN ONE HALF OF THE HOOD CAPTURING THE SHIELD BETWEEN THE STRAIN RELIEF AND THE BOTTOM HALF OF THE HOOD (FIG.4).
6. SNAP THE JACKSCREWS INTO POSITION AND POSITION CONNECTOR INTO THE BOTTOM HOOD HALF.
7. PLACE THE OTHER HALF OF THE HOOD INTO PLACE AND TIGHTEN TOGETHER WITH THE ASSEMBLY SCREWS.

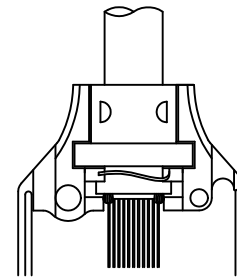
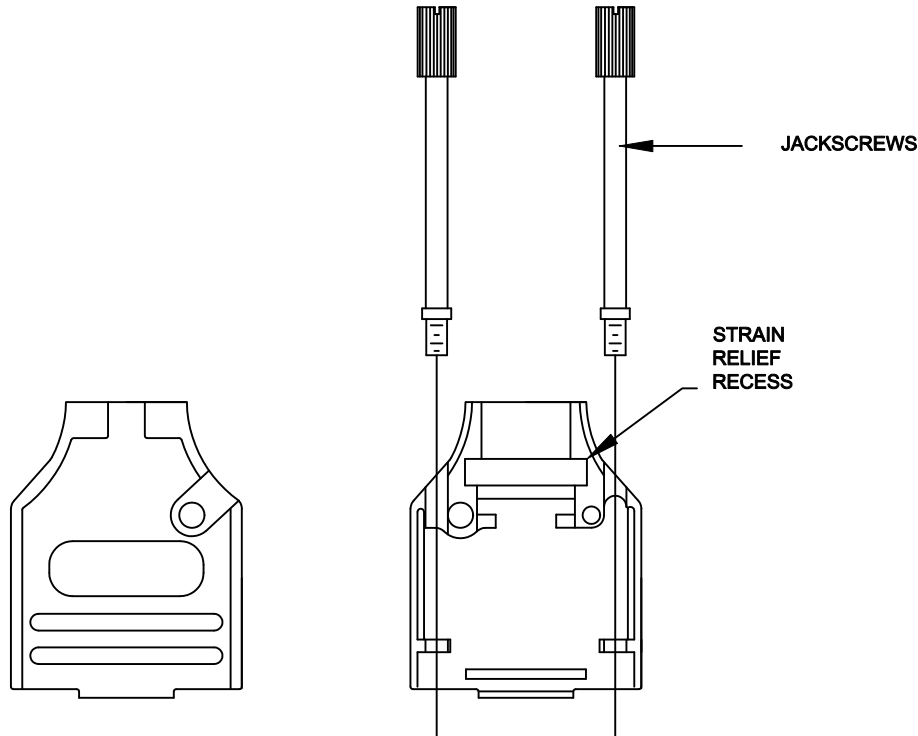

FIG. 4

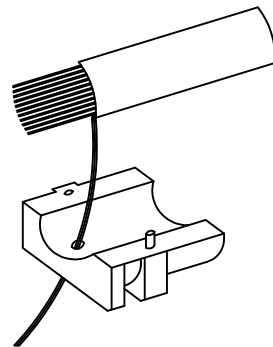

FIG. 1

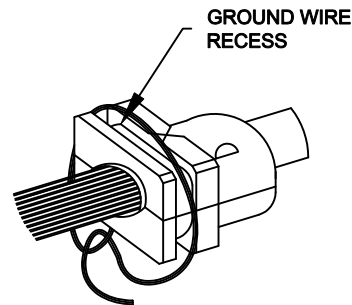

FIG. 2

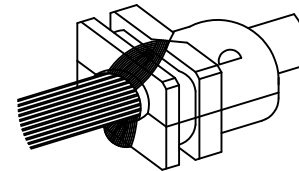

FIG. 3

METALIZED PLASTIC

THESE DRAWINGS AND SPECIFICATIONS ARE THE PROPERTY OF MH CONNECTORS LTD. AND SHALL NOT BE REPRODUCED, COPIED OR USED AS THE BASIS FOR THE MANUFACTURE OR SALE OF APPARATUS WITHOUT WRITTEN PERMISSION.

DRAWN P. JENKINS	DATE 03-23-12
APPROVED D. CROFT	DATE 03-23-12



MH CONNECTORS LTD.

SCALE NTS	SHEET OF 1 OF 1	REV: A
DRAWING No MHDTPK ASSEMBLY		