

PROPER USE GUIDELINES

Cumulative Trauma Disorders can result from the prolonged use of manually powered hand tools. Hand tools are intended for occasional use and low volume applications. A wide selection of powered application equipment for extended-use, production operations is available.

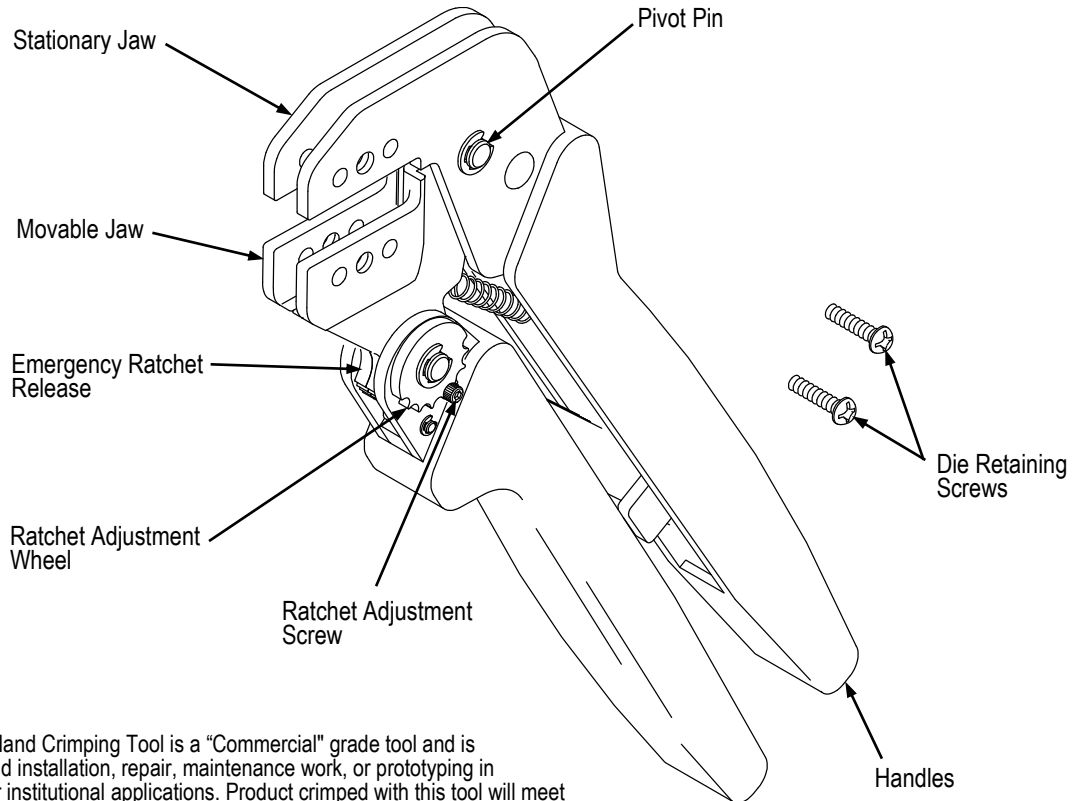

The PRO-CRIMPER III Hand Crimping Tool is a "Commercial" grade tool and is designed primarily for field installation, repair, maintenance work, or prototyping in industrial, commercial, or institutional applications. Product crimped with this tool will meet the crimp height requirement for hand tools in the appropriate Application Specification (114-series), but may not comply with other feature parameters of the specification. TE Connectivity offers a variety of tools to satisfy your performance requirements. For additional information, contact PRODUCT INFORMATION at 1-800-522-6752.

Figure 1

1. INTRODUCTION

This instruction sheet provides application and maintenance procedures for PRO-CRIMPER III Hand Crimping Tool Frame Assembly 354940-1, shown in Figure 1. The tool is designed to accept interchangeable die assemblies for crimping various types of products.



NOTE

In most cases, the tool frame assembly is provided with a specific set of dies and is considered a component part of a crimping assembly. Refer to the appropriate instruction sheet packaged with the hand tool and die assembly or with the separate die assembly for information regarding crimping procedures, crimp height inspection, and die gaging.

Read these instructions thoroughly before installing dies and using the tool frame.

Reasons for reissue of this instruction sheet are provided in Section 7, REVISION SUMMARY.

2. DESCRIPTION

The tool frame consists of two crimping jaws, an adjustable ratchet, spring-actuated handles, two die retaining screws, and an emergency ratchet release. The slotted design of the tool jaws permits easy installation and removal of dies. The adjustable ratchet allows handle pressure to be set for optimum die performance.

3. DIE INSTALLATION AND REMOVAL

Select the desired die assembly, remove the die retention screws from the tool jaws, and proceed as follows:

3.1. Shouldered Dies (See Figure 2)

1. Place the upper die in the stationary jaw of the tool frame.
2. Insert a die retention screw through the jaw and die, and tighten the screw so that the die is held in place, but that the screw is not completely tightened at this point.



NOTE

Install die assemblies with center contact crimping chamber with the center contact crimp chamber toward the front of the tool jaws as shown in Figure 2. If indicated otherwise in another document, follow the specific die requirements demonstrated in that document.

3. Place the lower die in the moving jaw of the tool frame. Install a die retention screw through the jaw and die, and tighten the screw so that the die is held in place, but that the screw is not completely tightened at this point.
4. Slowly close the tool handles, allowing the dies to mate and/or align. Continue closing the tool handles until the ratchet makes the seventh "click," then tighten both die retention screws until snug.



NOTE

The tool ratchet has detents that are audible in eight "clicks" as the handles are closed. The ratchet releases on the eighth "click".

5. To remove the die assembly, close the tool handles until the ratchet releases, and allow the handles to open fully. Loosen and remove the die retention screws and slide the dies out of the tool jaws.

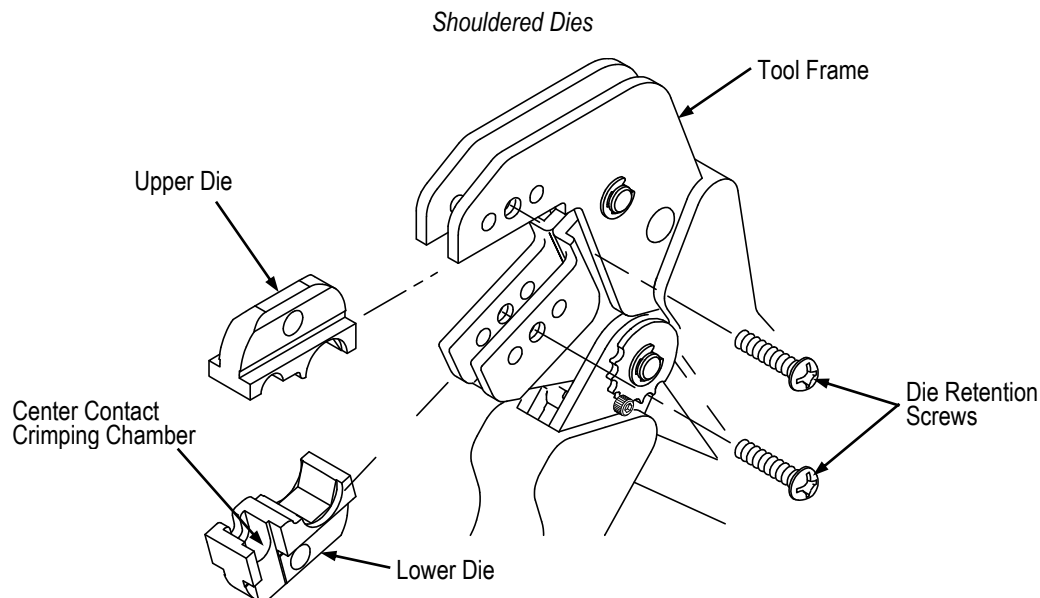

Figure 2

3.2. Pinned Dies (See Figure 3)

1. Install the wire and insulation anvil dies with the chamfers facing the front of the tool and the die markings facing outward into the movable jaw of the tool frame.
2. Insert the die retaining pins and the short die retention screw. Do not tighten the screw completely.
3. Install the wire and insulation crimper dies with the chamfers facing the front of the tool and the die markings facing outward into the stationary jaw of the tool frame.
4. Insert the die retaining pins and the long die retention screw. Do not tighten the screw completely.

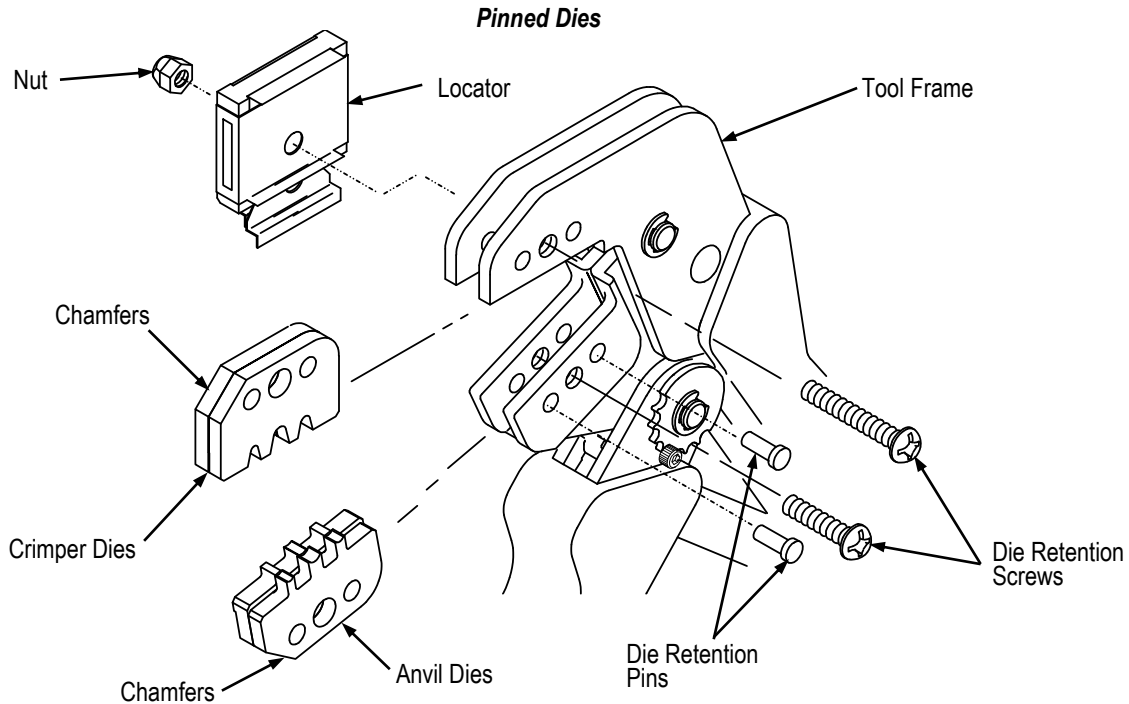

Figure 3

5. Slowly close the tool handles, allowing the dies to mate and/or align. Continue closing the tool handles until the ratchet makes the seventh “click”, then tighten both die retention screws until snug.

NOTE

The tool ratchet has detents that are audible in eight “clicks” as the handles are closed. The ratchet releases on the eighth “click”.

6. Install the locator assembly and tighten the hex nut.
7. Reverse these steps to remove the die assembly.

4. CRIMP HEIGHT ADJUSTMENT

The tool frame features a ratchet mechanism and adjustment wheel with a range of settings. The ratchet mechanism ensures that the tool has completed the cycle. The adjustment wheel controls the amount of handle pressure exerted on the jaws and dies during the crimping procedure. Although the ratchet is preset prior to shipment, it is important that the crimp height be verified. Also, general use and subsequent wear may cause the tool to go out of adjustment.

It is recommended that the crimp height be inspected and adjusted, if necessary, on a regular basis by quality control personnel.

NOTE

This is a general explanation of the adjustment. For specific information, refer to the instruction sheet packaged with the die assembly.

1. Crimp a connector onto a properly-prepared wire of correct size.
2. If the crimp height is greater than recommended, remove the ratchet wheel adjustment screw and rotate the adjustment wheel COUNTERCLOCKWISE to a higher setting. Repeat as required.
If the crimp height is less than recommended, remove the ratchet wheel adjustment screw and rotate the adjustment wheel CLOCKWISE to a lower setting. Repeat as required.
If the crimp cannot be made to conform to the dimensions provided in the applicable product application specification, the tool and/or dies are defective and must be replaced.

5. MAINTENANCE AND INSPECTION

5.1. Initial Inspection

PRO-CRIMPER III Hand Crimping Tool Frame Assembly 354940-1 is inspected prior to shipment. It is recommended that it be inspected upon arrival to ensure that it has not become damaged during shipping.

5.2. Daily Maintenance

It is recommended that operators of the tool be made aware of, and responsible for, the following steps of daily maintenance:

1. Remove dust, moisture, and any other contaminants from the tool with a clean, soft brush, or a clean, soft, lint-free cloth. Do NOT use hard or abrasive objects that could damage the tool.
2. Make certain that the pivot pins are in place and that they are secured with retaining rings.
3. All pins, pivot points, and bearing surfaces should be protected with a thin coat of any good SAE 20 motor oil. Do not oil excessively.
4. When the tool is not in use, keep handles closed to prevent objects from becoming lodged in the jaws. Store the tool in a clean, dry area.

5.3. Periodic Inspection

Regular inspections of the tool should be performed by quality control personnel. A record of scheduled inspections should remain with the tool or be supplied to personnel responsible for the tool. Inspection frequency should be based upon amount of use, working conditions, operator training and skill, and established company standards.

1. Remove all lubrication and accumulated film by immersing the tool (handles partially closed) in a suitable commercial degreaser that will not affect paint or plastic material.
2. Make certain that all pivot pins are in place and secured with retaining rings.
3. Close the tool handles until the ratchet releases and then allow them to open freely. If they do not open quickly and fully, the spring is defective and must be replaced. See Paragraph 6, REPLACEMENT AND REPAIR.
4. Inspect the tool frame for wear or damage, paying particular attention to the jaws and pivot points. If damage is evident, refer to Paragraph 6, REPLACEMENT AND REPAIR. If tool is acceptable, lubricate it, and return it to service.

6. REPLACEMENT AND REPAIR

Order a new tool frame or die assembly through your TE Representative, or call 1-800-526-5142, or send a facsimile of your purchase order to 717-986-7605, or write to:

CUSTOMER SERVICE (038-035)
TYCO ELECTRONICS CORPORATION
PO BOX 3608
HARRISBURG PA 17105-3608

7. REVISION SUMMARY

- Updated document to corporate requirements
- Changed amount of “clicks” in Paragraphs 3.1.4 and 3.2.5 and NOTES in Paragraphs 3.1.4 and 3.2.5.