

Photovoltaic connector - PV-FT-CM-C-2,5-130-RD - 1805148

Please be informed that the data shown in this PDF Document is generated from our Online Catalog. Please find the complete data in the user's documentation. Our General Terms of Use for Downloads are valid (<http://download.phoenixcontact.com>)



Photovoltaic connector, Nominal current: 27 A, Nom. voltage: 1500 V, Connection type: Crimp, Color: black, Can only be released using a tool

Key commercial data

package_quantity	50
GTIN	4046356671439

Technical data

Dimensions

Fixed cable length	130 mm
External cable diameter	4.25 mm ±0.15

Ambient conditions

Degree of protection (when plugged in)	IP66 / IP68 (2m / 24h)
Degree of protection (not plugged in)	IP65
Ambient temperature (operation)	-40 °C ... 85 °C
Ambient temperature (assembly)	-25 °C ... 50 °C

General

Design	Male connector
Tightening torque nut	1.8 Nm ±0.1 N
Insertion force	45 N ±10 N
Disconnect force	250 N ±50 N
Pull-out force of cable >= disconnect force	> 80 N

General

Rated voltage	1500 V
Rated current (2.5 mm²)	27 A
Nominal cross section	2.5 mm²
Protection class	II

Material

Color	black
Insulating material	mPPE
Contact material	Cu
Contact surface material	Ag

Photovoltaic connector - PV-FT-CM-C-2,5-130-RD - 1805148

Technical data

Material

Inflammability class according to UL 94	V0
---	----

Connection data

Connection method	Crimp
Connection capacity	2.5 mm ²
Contact resistance with connected conductor	0.45 mΩ
Cable type	S01

Conductor

Outer sheath, material	PE-X
External sheath, color	red
Smallest bending radius, fixed installation	21.25 mm
Smallest bending radius, movable installation	42.5 mm

classifications

eCl@ss

eCl@ss 4.0	272607xx
eCl@ss 4.1	27260701
eCl@ss 5.0	27260701
eCl@ss 5.1	27141190
eCl@ss 6.0	27260704
eCl@ss 7.0	27440402
eCl@ss 8.0	27440402

ETIM

ETIM 3.0	EC001121
ETIM 4.0	EC001753
ETIM 5.0	EC002641

UNSPSC

UNSPSC 6.01	30211810
UNSPSC 7.0901	39121409
UNSPSC 11	39121409
UNSPSC 12.01	39121409
UNSPSC 13.2	39121409

approvals

VDE Zeichengenehmigung /

Approval details

Photovoltaic connector - PV-FT-CM-C-2,5-130-RD - 1805148

approvals

VDE Zeichengenehmigung	
Nominal voltage UN	1500 V
Nominal current IN	27 A
mm ² /AWG/kcmil	2.5

accessories

Flat nut

PV-FT-C NUT BK - 1775880



Protective cap

PV-C PROTECTION CAP - 1785430



Drawings

Photovoltaic connector - PV-FT-CM-C-2,5-130-RD - 1805148

Dimensioned drawing

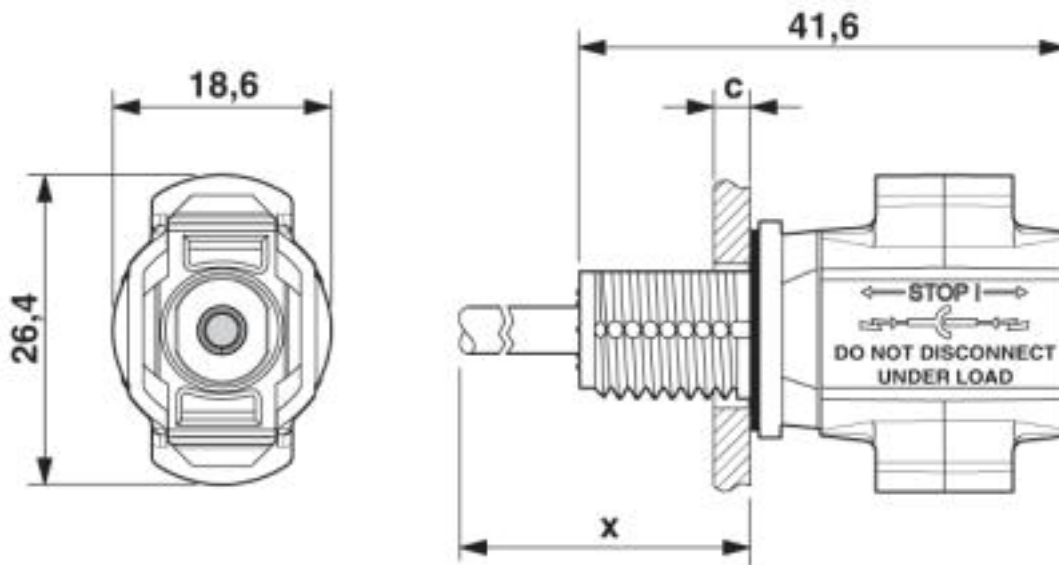

Dimension x = cable length: panel thickness - plastic: 2 - 6 mm; metal:
2 - 5 mm

Photovoltaic connector - PV-FT-CM-C-2,5-130-RD - 1805148

Dimensioned drawing

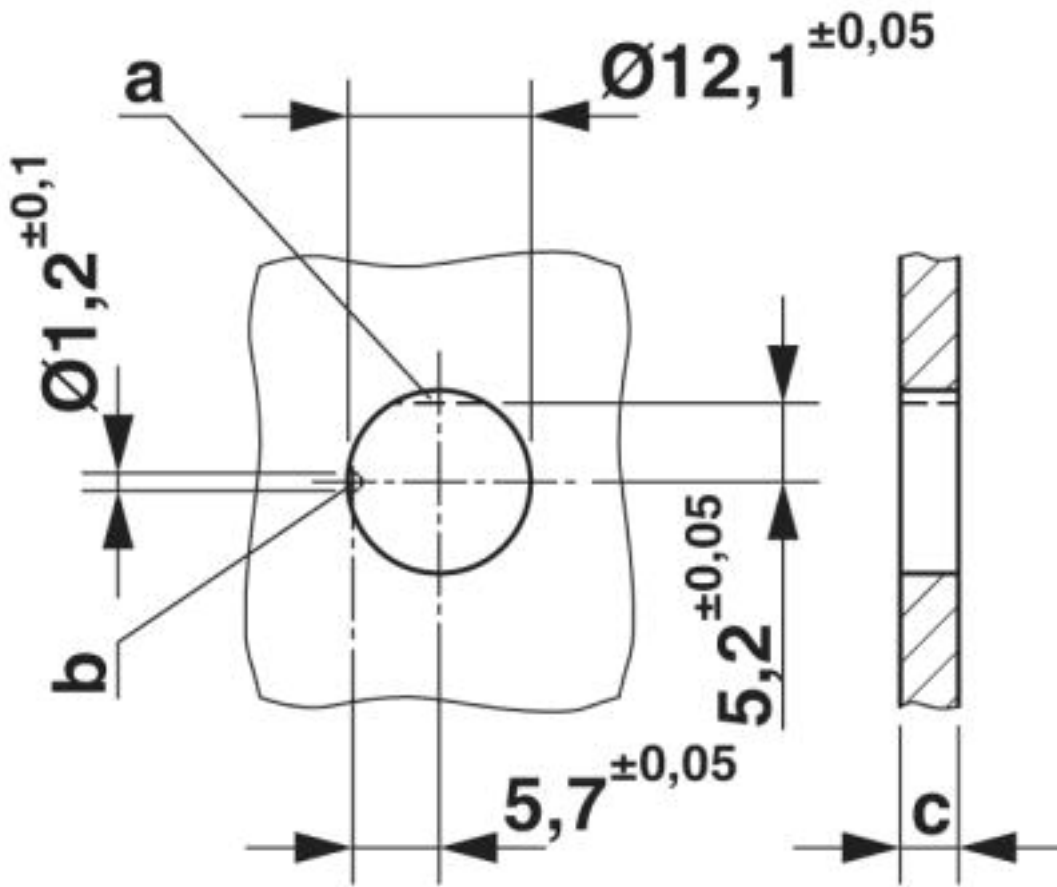

© Phoenix Contact 2013 - all rights reserved
<http://www.phoenixcontact.com>