



Mini Clamp Wiremount Plug Connector

COMPATIBLE OBJECT

1. Compatible connectors

3M Brand : 372XX-62X3-00X XX :Mini-Clamp board mount socket connector.

3M Brand : 3730X-XXXX-0X0 XX :Mini-Clamp wire mount socket connector.

2. Compatible cable

Conductor cross sectional area AWG20 26 0.14 0.5mm²

Conductor material Tin plating annealed copper wire, High strength copper alloy wire, Copper alloy wire

Conductor structure Stranded wire, Tin overcoat wire, Solid wire

Conductor construction

AWG20(0.5sq) 19/0.20 20/0.18 21/0.18

AWG22(0.3sq) 1/0.643 7/0.254 12/0.18 17/0.16 3/20/0.08 60/0.08

AWG24(0.2sq) 7/0.20 11/0.16 40/0.08

AWG25(0.18sq) 7/0.18 36/0.08 37/0.08 7/13/0.05

AWG26(0.14sq) 7/0.16 30/0.08 7/11/0.05

Isolation material Heat-resistant vinyl, Half rigid vinyl, Cure PE, ETFE,

Isolation outside diameter 0.8 2.0

- Above adaptation electric wire is an extract from evaluation electric wire and doesnot evaluate all combinations. Detailed information please ask the sales person incharge.
- This connector recommend electric wire witch is stranded wire of pitch equal to orless than 20 times of conductor outside diameter prescribed with section A4-2-4-3in “Insulated conductors for power-operated electronic devices” by CSA standardC22.2No.16-1980 There is the thing which even pitch more than this conforms to.Detailed information please ask the sales person in charge.
- On flat cable, IDC is possible by tearing it up if it is welding cable. In addition, with flat cable of pushing out molding, IDC is possible by dividing quality ofinsulation with cutters equally. Not being shown electric wire.
- If it is electric wire of seven twisting on AWG 28, it is almost meets. Detailed information please ask the sales person in charge.
- Please ask the sales person in charge on junction of shielding wire.

3. Recommendation tool

IDC by prier

To use base plate (10986, 3771) together in 3M hand press machine (10985, 3640, 3335), and platen (3442-1A),Can make IDC which height adjusts for 3 with height gauge (3436-1A).

4. An instruction manual

ER-077 Mini-Clamp connector IDC sequence of operation book

5. Caution of operation

Please use it for do not add force to IDC part (don't pull electric wire).

Demolition at having pulled electric wire changes by thickness of electric wire.

Please install it so that connected load more than 10 N is not added per wire.

Please don't IDC without jig (for example, dukes / finger).

Note A breaking strength ability value at having pulled it to the direction that electric wire passed through. Above numeric value is changed by combination of connector and electric wire. It mentions typical numeric value example here.

Example 1) At the time of combination with UL1723, AWG22 (1/0.643), finish contour f 1.36, FEP isolation outer bark electric wire made in Showa Electric Wire & Cable Co.,Ltd. and 37104-2165-000 FL made in 3M

An average of 84.7 N (the fewest 78.5N)



Mini Clamp Wiremount Plug Connector

Example 2) At the time of combination with UL1007, AWG24 (11/0.16), finish contour f 1.49, Heat-resistant vinyl isolation outer bark electric wire made in Showa Electric Wire & Cable Co.,Ltd. and 37104-3163-000 FL made in 3M
An average of 46.6 N (the fewest 35.9N).

Example 3) At the time of combination with IR-1, 0.14SQ (7/0.16), finish contour f 1.34, Cure PE isolation outer bark electric wire made in Showa Electric Wire & Cable Co.,Ltd. and 37104-3163-000 FL made in 3M
An average of 23.0N (the fewest 18.8N).

Quality Performance

Unit Characteristics

TEST DESCRIPTION	REQUIREMENT	TEST CONDITION	RELATED STD. □Reference□
Dielectric with-standing voltage	No appearance of arcing and break down. Leak current : 1mA MAX	Impressed voltage is AC 1000V rms between two adjacent contacts for 1 minutes.	MIL-202F-301
Insulation Resistance	1000M□MIN	Impressed voltage is DC500V between two adjacent contacts for 1minutes.	MIL-202F-302

Mating characteristic

It depends on combination with the Mini-Clamp connector series 372XX & 37304 series

TEST DESCRIPTION	REQUIREMENT	TEST CONDITION	RELATED STD. □Reference□
Insertion & Withdrawal Force (Initial)	Insertion□2N/pin MAX. Withdrawal□0.5N/pin MIN.	Tensile speed : 5mm/min. Spec. value is estimated by one contact pin.	
Retention Force of Latch	58.8N MIN.	Tensile speed: 25mm/min.	
Vibration	Electrical properties shall be stable after test. Discontinuity 1□sec. Max.	Tested during vibration test together (See table 1)	MIL-202F-201 A
Shock	Electrical properties shall be stable after test. Discontinuity 1□sec. Max.	50G , 11 m sec , 3 cycles, 3 directions (X,Y,Z)	MIL-202F-213 B

Electrical Specifications

TEST DESCRIPTION	REQUIREMENT	TEST CONDITION	RELATED STD. □Reference□
Electrical Continuity	Electrical properties shall be state under test. Discontinuity 1□sec MAX.	Tested during Vibration test together	Refer TABLE-2
Contact Resistance	The initial readings are in milli-ohms. 20m□MAX.	The low-signal level contact resistance shall be tested with circuit current of 1mA and open circuit voltage of 20 mV maximum. The termination resistance includes bulk resistance of contact, and resistance of solder joints of connectors to circuit boards.	



Mini Clamp Wiremount Plug Connector

Electrical Specifications

Contact Resistance	After evaluation tests readings are the change in resistance from the initial reading in milli-ohms. $\pm 25m$ <input type="checkbox"/> MAX.	FL type - 3M SEQUENCE 1 <input type="checkbox"/> Mating(50 cycles) <input type="checkbox"/> Moisture <input type="checkbox"/> Salt splay - 3M SEQUENCE 2 <input type="checkbox"/> Thermal shock <input type="checkbox"/> Humidity <input type="checkbox"/> Vibration - 3M SEQUENCE 3 <input type="checkbox"/> Temperature life - H2S GAS SEQUENCE <input type="checkbox"/> Mating (50 cycles) <input type="checkbox"/> H2S gas - Durability <input type="checkbox"/> Mating (500 cycles)	Refer TABLE-2
--------------------	--	---	---------------

Environmental Tests

ITEM	TEST CONDITION	RELATED STD. <input type="checkbox"/> Reference <input type="checkbox"/>
Moisture	-10 to 65°C , 95%RH / 10 cycles	MIL-202F-106 E
Salt spray	Salt solution : 5% (NaCl) Temperature : 35 <input type="checkbox"/> Duration: 48 hours	MIL-202F-101 D
Thermal shock	- 55°C => 25°C => 85°C => 25°C / 5 cycles	MIL-202F-107 G
Humidity (Steady state <input type="checkbox"/>	Temperature range : 40 <input type="checkbox"/> Relative humidity : 95%RH Duration: 96 hours	MIL-202F-103 B
Temperature Life	Temperature : 85°C Current : 1A Duration: 1000 hours	MIL-202F-108 A
H ₂ S gas	H ₂ S gas : 3 \pm <input type="checkbox"/> PPM Temperature : 40 <input type="checkbox"/> Humidity: 70~80%RH Duration: 96 hours	JEIDA-34-1984
Vibration	Sweep freq.: 10~55Hz, amplitude: 1.52mm (or 10G) Sweep cycle: 1 min, sweep time: 2 hours Sweep directions: X, Y, Z	MIL-202F-213 B

STORAGE CONCITION

-22 degrees to 55 degrees,
Relative humidity 5-95%,
Without dewdrop and a drop of water.

PACKAGE & IDENTIFICATION

It puts it in plastic tray, and this article is shipped with form packed with carton more. Carton box is identified of 1) part number, 2) quantity, and 3) maker name and 4) lot number.



Mini Clamp Wiremount Plug Connector

Wiremount Plug 3 position

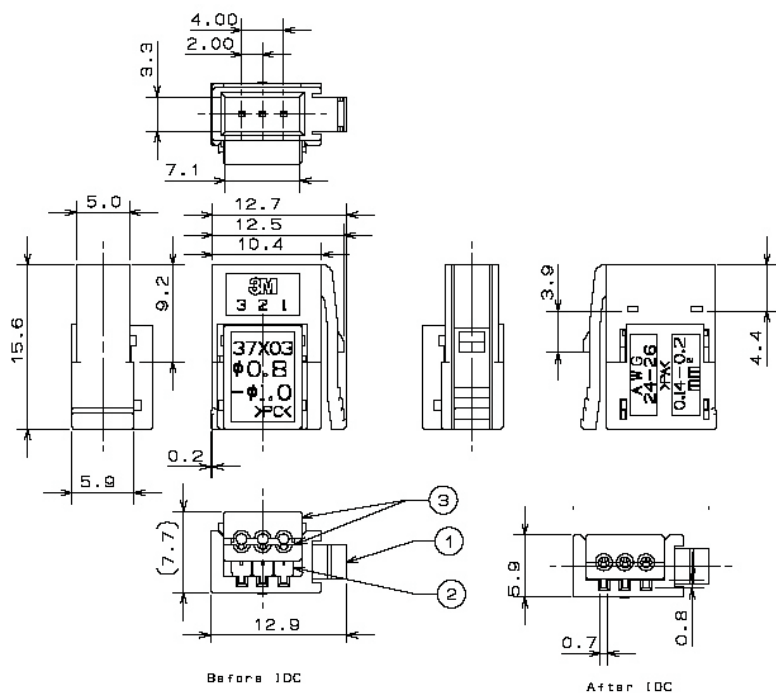

37103-3101-000 FL	rot
37103-3122-000 FL	Gelb
37103-3163-000 FL	Orange
37103-2124-000 FL	grün
37103-2165-000 FL	Blau
37103-2206-000 FL	grau

Wiremount Plug 4 position

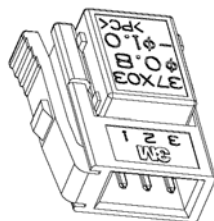



Mini Clamp Wiremount Plug Connector

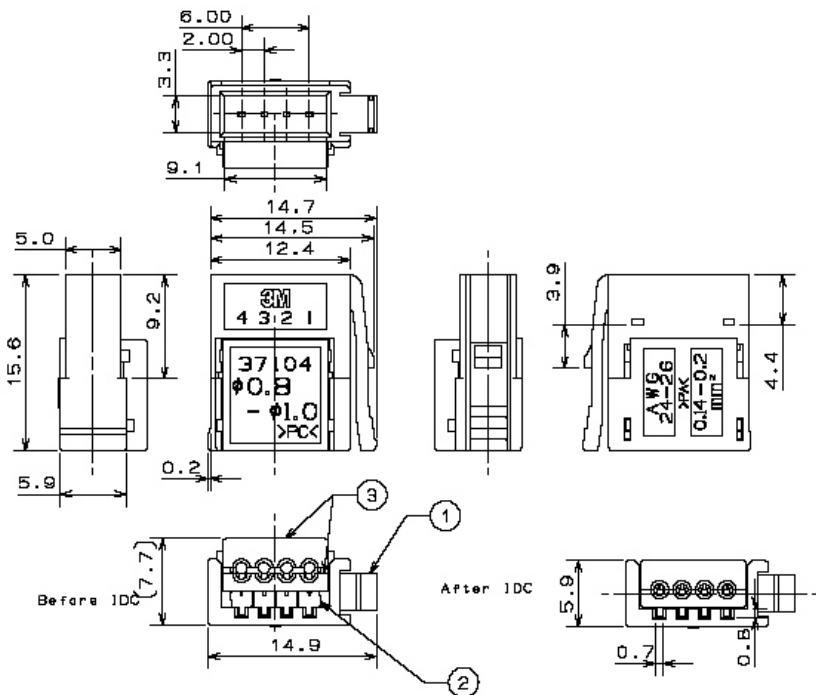

37104-3101-000 FL	rot
37104-3122-000 FL	Gelb
37104-3163-000 FL	Orange
37104-2124-000 FL	grün
37104-2165-000 FL	Blau
37104-2206-000 FL	grau

