

LOC	DIST	REVISIONS					
A1	-	P	LTR	DESCRIPTION	DATE	DWN	APVD
		A		new drawing	11FEB2002	-	-
		A1		ECR-06-024201	13.10.06	MD	LB

Kontakt Contact	DGB (mm ²) Wire Range	Drahtcrimp/Wirecrimp		Isocrimp	Iso.-∅ Ins. Range	Dichtung Seal	Betriebsanl. Instr. Sheet
		Hoehe/Height	Breite/Width	Breite/Width			
183035 / 183036	0.35-0.5	1.00	2.03	4.06	1.4-1.7	281934-4	411-18228
183024 / 183025	0.75	1.29	2.29		1.8-3.3	281934-2	
	1.0	1.37					
	1.5	1.53					

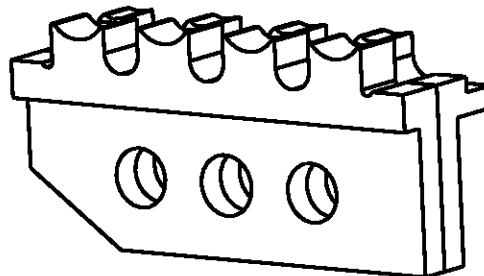
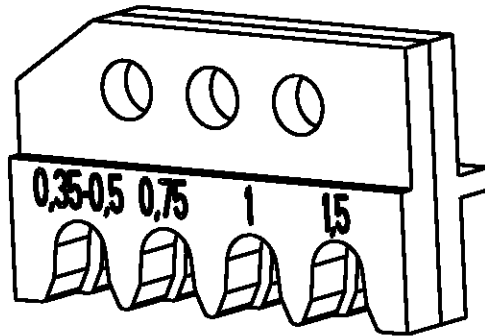

539773-2	1	2-539787-1	locator ass.	Positioniereinheit	A
	1	1-519151-3	screw M4x25	Schraube M4x25	A
	1	0-519151-9	screw M4x10	Schraube M4x10	A
	1	0-519024-2	hex nut M4	Mutter M4 DIN 985	A
	QTY Stck	PN	Description	Benennung	REV

RELEASED FOR PUBLICATION 19

THIS DRAWING IS UNPUBLISHED.

COPYRIGHT 19 BY TYCO ELECTRONICS CORPORATION. ALL RIGHTS RESERVED.

DIMENSIONS: mm-DIN 7168-m		DWN M.Weberdoerfer 30NOV99	MATERIAL -	FINISH -
TOLERANCES UNLESS OTHERWISE SPECIFIED:		CHK U.Reuter 30NOV99	tyco Electronics AMP GmbH D - 64625 Bensheim	
0 PLC ± 1 PLC ± 2 PLC ± 3 PLC ± 4 PLC ± ANGLES ±		APVD -		
		PRODUCT SPEC -	NAME ERGOCRIMP Die Set for Mini Mic Rec. and Tab	
		APPLICATION SPEC -	SIZE A4	CAGE CODE 00779
WEIGHT -		RESTRICTED TO -		
CUSTOMER DRAWING			SCALE 2:1	SHEET 1 OF 1
			REV A1	