

Passive module - UM 45-FLK14/ 8IM/PLC - 2962887

Please be informed that the data shown in this PDF Document is generated from our Online Catalog. Please find the complete data in the user's documentation. Our General Terms of Use for Downloads are valid (<http://download.phoenixcontact.com>)



VARIOFACE COMPACT LINE, sensor module for the connection of 8 p-n-p sensors, for assembly on DIN rail NS 35/7.5, screw connection



Key commercial data

package_quantity	1
GTIN	4017918087487

Technical data

Dimensions

Width	75 mm
Height	45 mm
Depth	51 mm

Ambient conditions

Ambient temperature (operation)	-20 °C ... 50 °C
Ambient temperature (storage/transport)	-20 °C ... 70 °C

General

Nominal voltage U_N	< 50 V AC
Nominal voltage U_N	60 V DC
Max. current carrying capacity per branch	1 A
Max. total current of voltage supply	3 A
Number of positions	14
Test voltage	500 V (50 Hz, 1 min.)
Mounting position	Any
Standards/regulations	IEC 60664
Standards/regulations	DIN VDE 110
Pollution degree	2
Surge voltage category	II

Connection data for connection 1

Connection name	Field level
Connection method	Screw connection

Passive module - UM 45-FLK14/ 8IM/PLC - 2962887

Technical data

Connection data for connection 1

Conductor cross section solid min.	0.14 mm ²
Conductor cross section solid max.	1.5 mm ²
Conductor cross section stranded min.	0.14 mm ²
Conductor cross section stranded max.	1.5 mm ²
Conductor cross section AWG/kcmil min.	26
Conductor cross section AWG/kcmil max	14
Stripping length	6 mm
Screw thread	M3

classifications

eCl@ss

eCl@ss 4.0	27250313
eCl@ss 4.1	27250313
eCl@ss 5.0	27250313
eCl@ss 5.1	27250313
eCl@ss 6.0	27371601
eCl@ss 7.0	27371601
eCl@ss 8.0	27371601

ETIM

ETIM 2.0	EC001437
ETIM 3.0	EC001437
ETIM 4.0	EC001437
ETIM 5.0	EC001437

UNSPSC

UNSPSC 6.01	30211824
UNSPSC 7.0901	39121421
UNSPSC 11	39121421
UNSPSC 12.01	39121421
UNSPSC 13.2	39121421

approvals

GOST /

Approval details



Passive module - UM 45-FLK14/ 8IM/PLC - 2962887

Drawings

Circuit diagram

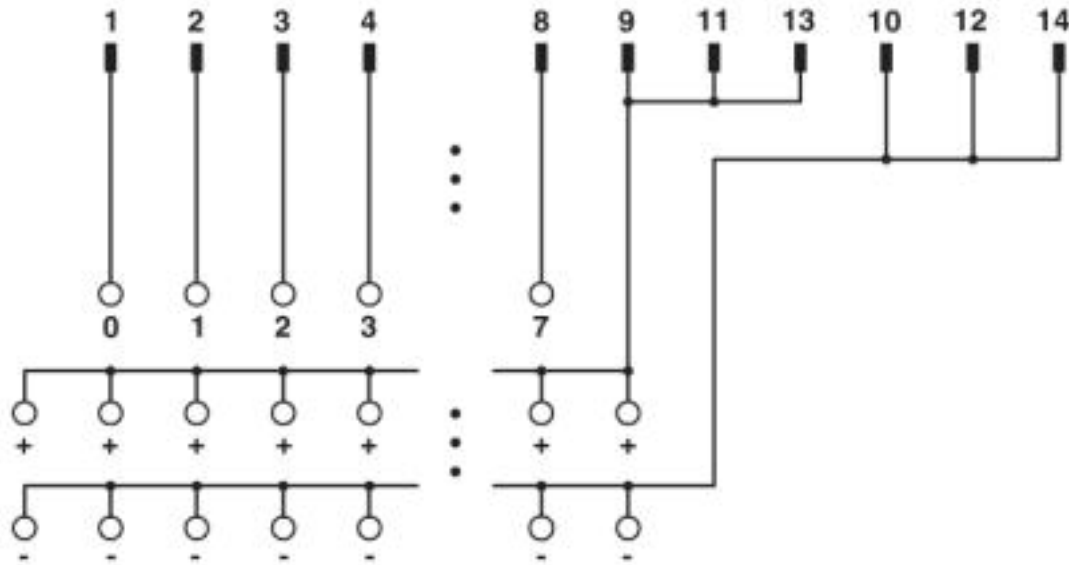

UM 45-FLK14/8IM/PLC connection scheme

© Phoenix Contact 2013 - all rights reserved
<http://www.phoenixcontact.com>