

D-SUB panel mounting frames - VS-09-A-GC-ST/ST - 1689705

Please be informed that the data shown in this PDF Document is generated from our Online Catalog. Please find the complete data in the user's documentation. Our General Terms of Use for Downloads are valid (<http://download.phoenixcontact.com>)



D-SUB panel mounting frame, shell size 1, with nine signal contacts, pin, gender changer, shielded, IP67 degree of protection



Key commercial data

| | |
|------------------|---------------|
| package_quantity | 5 |
| GTIN | 4017918929053 |

Technical data

Mechanical characteristics

| | |
|-----------------------------|-------|
| Number of positions | 9 |
| Insertion/withdrawal cycles | ≥ 200 |
| Color | gray |

Ambient conditions

| | |
|---------------------------------|------------------|
| Ambient temperature (operation) | -40 °C ... 80 °C |
| Degree of protection | IP67 |

Material data

| | |
|---|--|
| Inflammability class according to UL 94 | V0 |
| Housing material | PA |
| Contact carrier material | Polyester GF |
| Contact material | Copper alloy |
| Contact surface material | Hard gold-plated over nickel |
| Material | Plastic |
| Sealing material | Flat gasket: NBR; profile gasket: EPDM |
| Seal material | Flat gasket: NBR; profile gasket: EPDM |

Electrical characteristics

| | |
|-----------------------|-------|
| Rated voltage (III/3) | 125 V |
| Rated current | 5 A |

D-SUB panel mounting frames - VS-09-A-GC-ST/ST - 1689705

classifications

eCl@ss

| | |
|------------|----------|
| eCl@ss 4.0 | 27140816 |
| eCl@ss 4.1 | 27260701 |
| eCl@ss 5.0 | 27260701 |
| eCl@ss 5.1 | 27260701 |
| eCl@ss 6.0 | 27261203 |
| eCl@ss 7.0 | 27440202 |
| eCl@ss 8.0 | 27440202 |

ETIM

| | |
|----------|----------|
| ETIM 2.0 | EC000437 |
| ETIM 3.0 | EC000437 |
| ETIM 4.0 | EC000437 |
| ETIM 5.0 | EC002310 |

UNSPSC

| | |
|---------------|----------|
| UNSPSC 6.01 | 31261501 |
| UNSPSC 7.0901 | 31261501 |
| UNSPSC 11 | 31261501 |
| UNSPSC 12.01 | 31261501 |
| UNSPSC 13.2 | 31261501 |

accessories

Protective cover

VS-09-SD - 1887086



Drawings

D-SUB panel mounting frames - VS-09-A-GC-ST/ST - 1689705

Dimensioned drawing

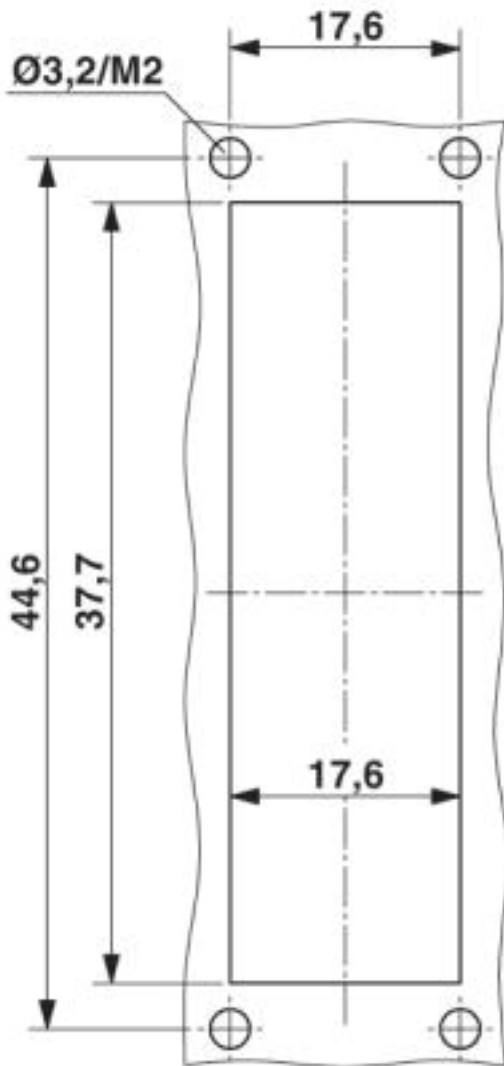

Mounting cutout: VS-09-A...

D-SUB panel mounting frames - VS-09-A-GC-ST/ST - 1689705

Dimensioned drawing

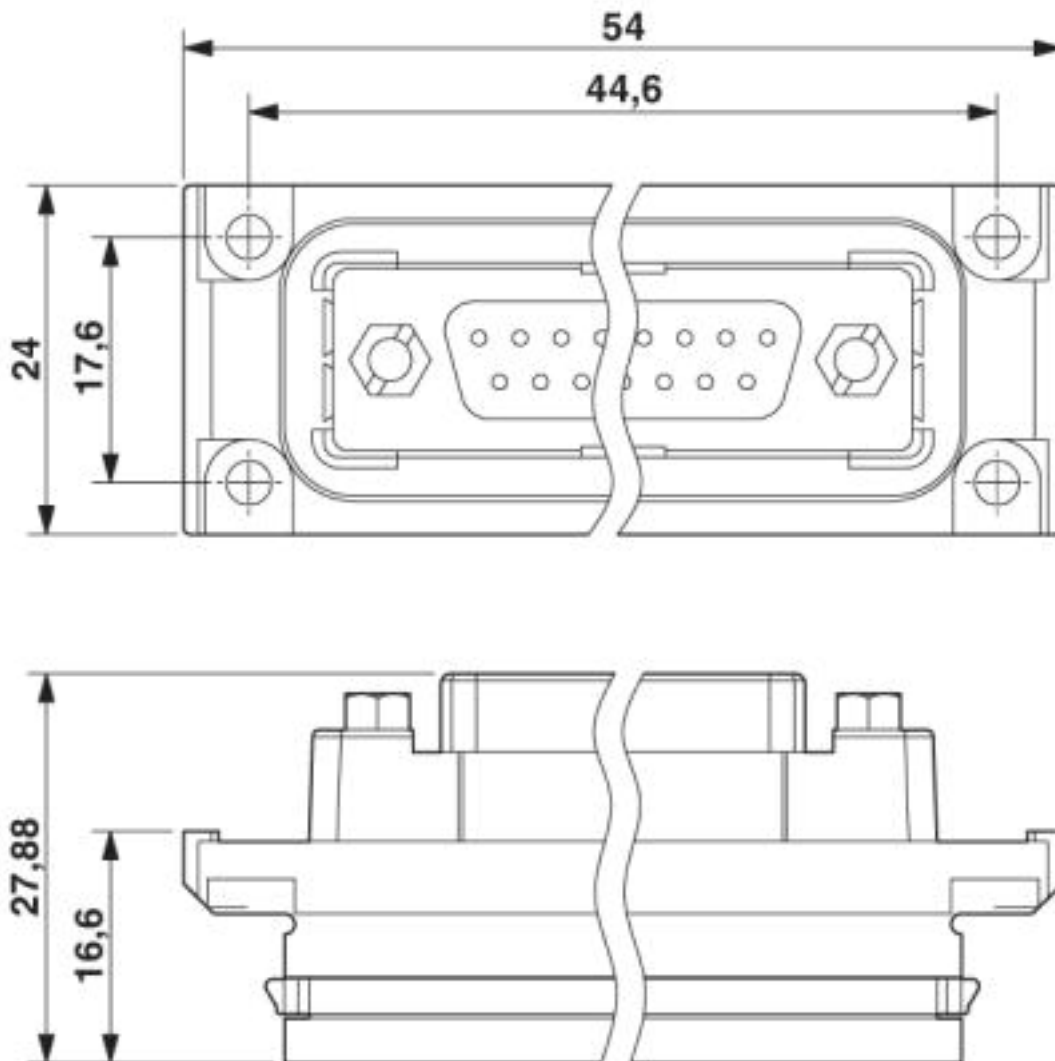

D-SUB panel mounting frame

© Phoenix Contact 2013 - all rights reserved
<http://www.phoenixcontact.com>