

D-SUB sleeve housings - VS-15-T-2PG11 - 1688052

Please be informed that the data shown in this PDF Document is generated from our Online Catalog. Please find the complete data in the user's documentation. Our General Terms of Use for Downloads are valid (<http://download.phoenixcontact.com>)



D-SUB sleeve housing, shell size 2, IP67 degree of protection

Key commercial data

package_quantity	5
GTIN	4017918179687

Technical data

Dimensions

Height	24 mm
Width	68.4 mm
Length	89 mm
External cable diameter	3 mm ... 10 mm

Ambient conditions

Ambient temperature (operation)	-40 °C ... 80 °C
--	------------------

General

Design	D-SUB 15
Color	gray
No. of cable exits	2
Cable exit	Angled
Type of the screw connection	Pg11
Housing material	PA
Inflammability class according to UL 94	V0

classifications

eCl@ss

eCl@ss 4.0	27140816
eCl@ss 4.1	27260701
eCl@ss 5.0	27260701
eCl@ss 5.1	27260701
eCl@ss 6.0	27261203
eCl@ss 7.0	27440290

D-SUB sleeve housings - VS-15-T-2PG11 - 1688052

classifications

eCl@ss

eCl@ss 8.0	27440290
------------	----------

ETIM

ETIM 2.0	EC000437
ETIM 3.0	EC000437
ETIM 4.0	EC000437
ETIM 5.0	EC000437

UNSPSC

UNSPSC 6.01	31261501
UNSPSC 7.0901	31261501
UNSPSC 11	31261501
UNSPSC 12.01	31261501
UNSPSC 13.2	31261501

accessories

Pressure nut

VS-PG11 (3- 7) - 1688117



VS-PG11 (5-10) - 1688104



Protective cap

Q-PROT 9/11 - 1670235



D-SUB sleeve housings - VS-15-T-2PG11 - 1688052

accessories

Data plug

VS-15-TI-2EMV - 1688065



Coding element

CP-HCC 4 - 1600027



Device marking

ZBN 18:UNBEDRUCKT - 2809128



Drawings

D-SUB sleeve housings - VS-15-T-2PG11 - 1688052

Dimensioned drawing

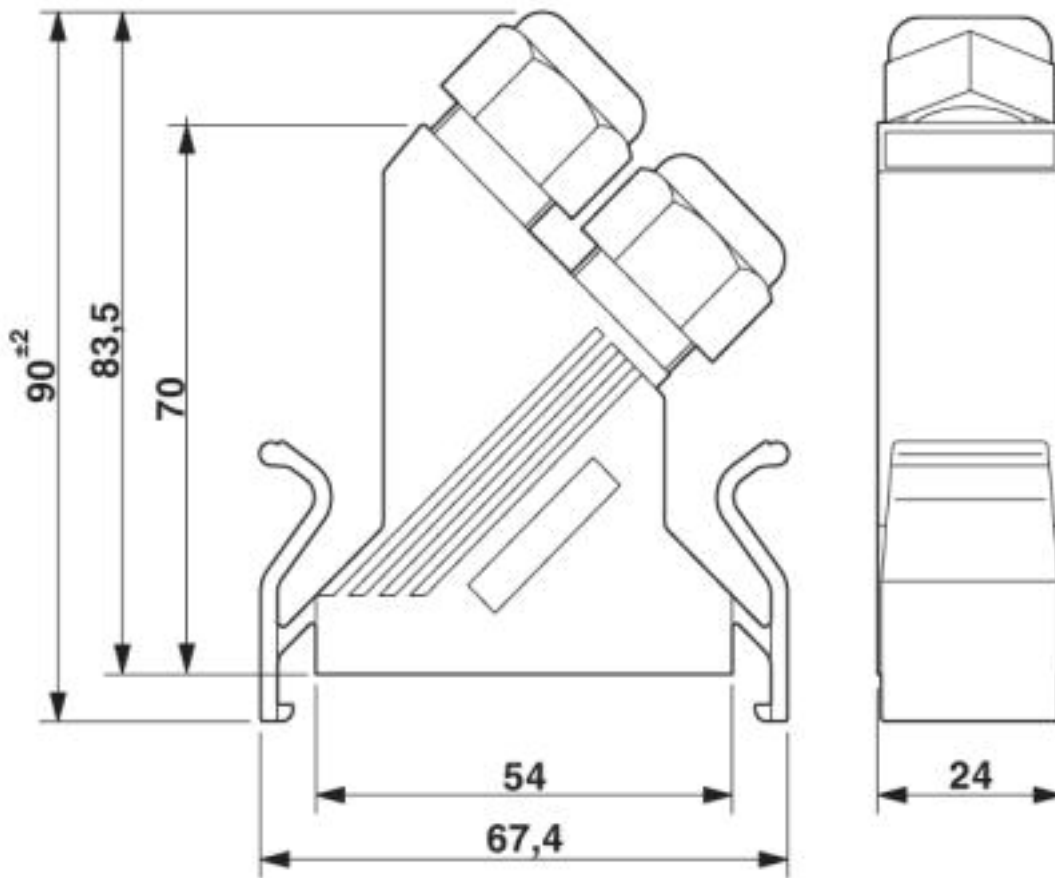

D-SUB sleeve housings

© Phoenix Contact 2013 - all rights reserved
<http://www.phoenixcontact.com>