

**PROPER USE GUIDELINES**

Cumulative Trauma Disorders can result from the prolonged use of manually powered hand tools. Hand tools are intended for occasional use and low volume applications. A wide selection of powered application equipment for extended-use, production operations is available.

ORIGINAL INSTRUCTIONS

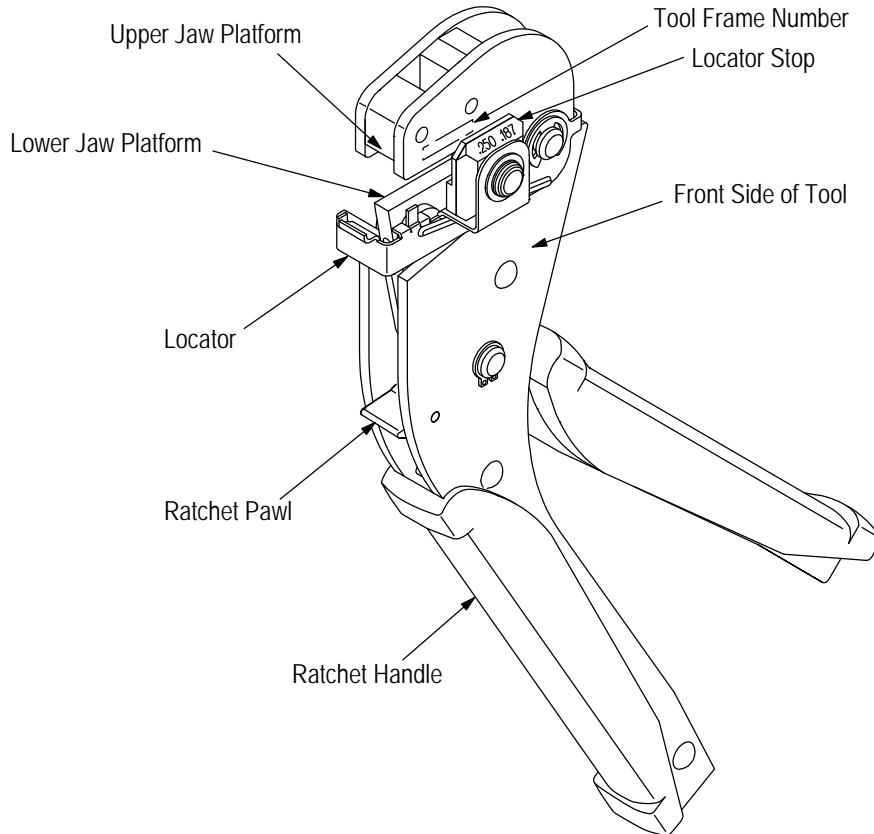

CRIMPING DIE ASSEMBLY			TERMINAL TYPE	WIRE SIZE	CRIMP DOT CODE
PART NUMBER	INSTRUCTION SHEET	COLOR DOT CODE			
58052-3	408-9277	Violet	Ultra-Fast Fully Insulated FASTON*	26-22	3
58079-3	408-9278	Red	Ultra-Fast Plus Fully Insulated FASTON	22-18	N/A
58080-3		Blue		16-14	N/A
90390-3	408-9279	Red	Ultra-Fast Fully Insulated FASTON	22-18	1
90391-3		Blue		16-14	2

Figure 1

**1. INTRODUCTION**

Hand Crimping Tool Frame 58078-3 accepts crimping die assemblies, listed in Figure 1, designed to crimp Ultra-Fast and Ultra-Fast Plus FASTON terminals onto wire sizes No. 26 through 14 AWG. Catalogs 82042 and 82004 provide guidance for wire-to-terminal selection. For wire sizes and terminals not referenced in the catalog, contact TE Connectivity for recommendations. Read these instructions thoroughly before using the tool frame.

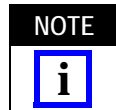

*Measurements are in metric units [with U.S. customary units in brackets]. Figures and illustrations are for reference only and are not drawn to scale.*

Reasons for reissue are provided in Section 7, REVISION SUMMARY.

**2. DESCRIPTION**

Each tool frame features a lower jaw platform, an upper jaw platform, a spring-loaded locator assembly

with an adjustable locator stop, and a ratchet handle with a ratchet pawl. The tool frame number is marked on the FRONT side of the tool frame. See Figure 1.

The upper jaw platform has a mounting hole and the lower jaw platform has a socket head setscrew for securing the die assembly. The locator assembly aids in positioning the terminal between the crimping dies and the locator stop adjusts for the various series size of terminals. The ratchet handle assures full crimping. Once engaged, the ratchet will not release until the tool frame handles have been FULLY closed, unless the ratchet pawl is depressed to manually release the ratchet. Use the manual release only when a terminal is improperly positioned.

**CAUTION** *The crimping dies bottom before the ratchet releases. This is a design feature that assures maximum electrical and tensile performance of the crimp. Do NOT re-adjust the ratchet.*

### 3. DIE ASSEMBLY INSTALLATION

The crimping die assembly consists of a lower die and an upper die, each marked with a color dot code that must match the color-coded terminal. The crimp dot code that will appear on the crimped terminal indicates the correct die assembly used. Refer to Figure 1. When closed, the die assembly forms two crimping chambers, each marked with the wire size range.

#### 3.1. Installing Lower Die

1. Close tool frame handles until ratchet releases, then allow handles to open FULLY.
2. Slide lower die onto lower jaw platform of tool frame. Make sure that the hole on the side of the lower die aligns with the socket head setscrew on the platform. See Figure 2.

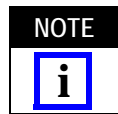

*If lower die will not position properly, use hex wrench provided with die assembly to turn socket head setscrew either in or out until lower die positions properly.*

3. Using hex wrench, turn socket head setscrew CLOCKWISE until snug. Do NOT overtighten.

#### 3.2. Installing Upper Die

1. Remove die retention screw from upper die.
2. Slide upper die onto upper jaw platform of tool frame. Make sure the color dot code on upper die is on the same side as the color dot code on lower die. See Figure 2.
3. Insert die retention screw through mounting hole in top of tool frame and thread, but do not tighten, the screw.
4. Carefully close the tool handles, making sure that the dies align properly.
5. Tighten the die retention screw until secure.

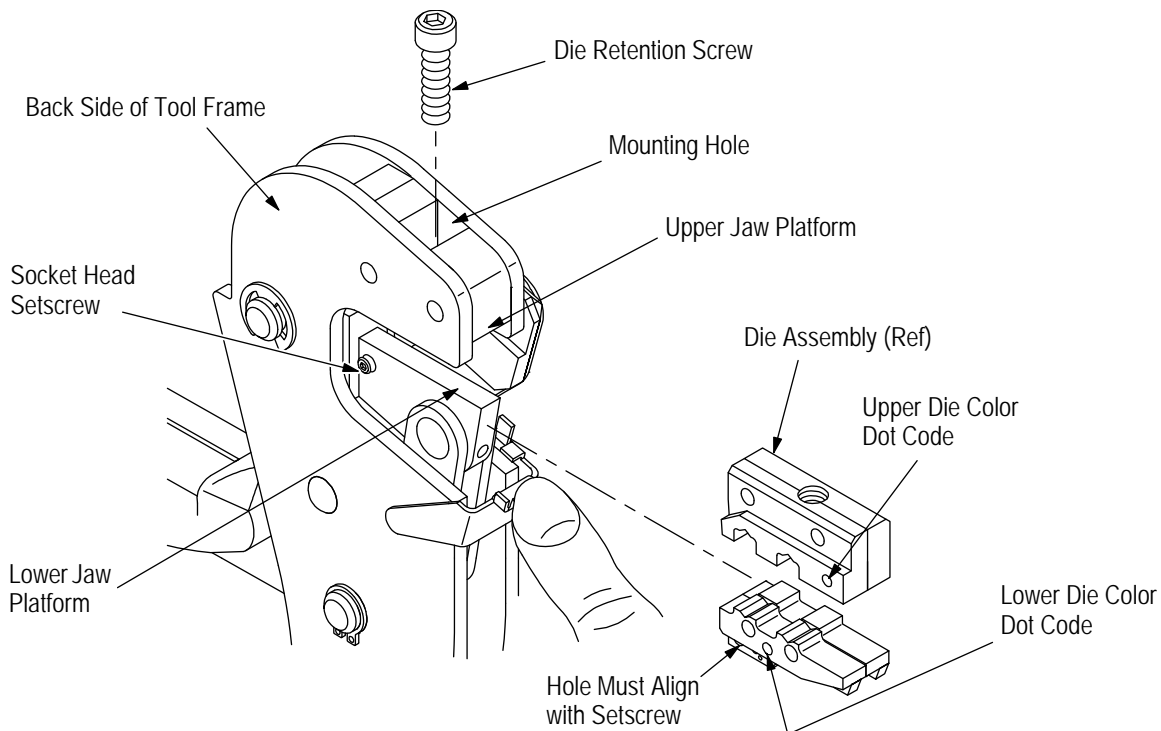
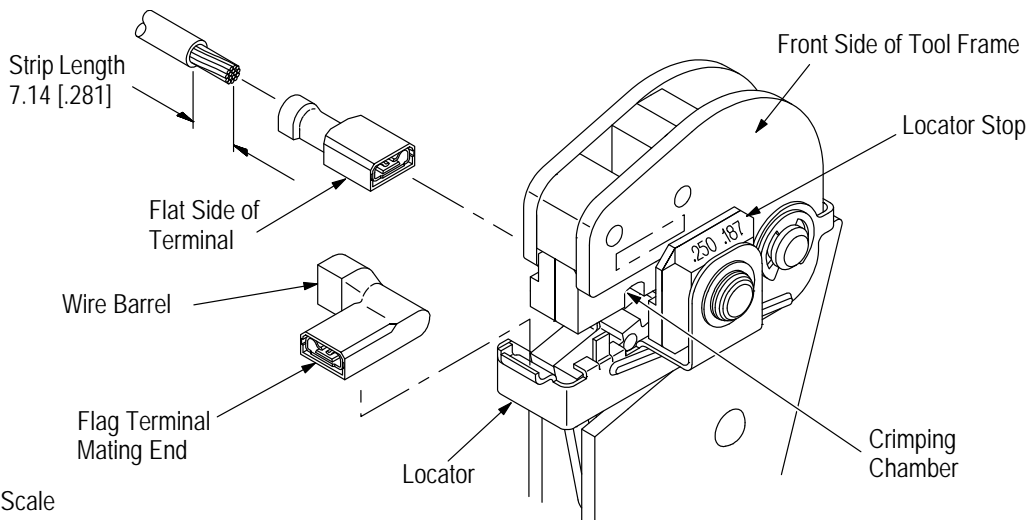

Figure 2



NOTE: Not to Scale

Figure 3

#### 4. CRIMPING PROCEDURE

Select the appropriate wire size and terminal for the die assembly. The wire size and insulation diameter must be within a specified range for the terminal. Strip the wire to the appropriate length shown in Figure 3. Do NOT cut or nick the wire strands. Then, proceed as follows:

1. Open crimping dies by squeezing tool frame handles together until ratchet releases.
2. Hold tool frame so that the FRONT side is facing you.
3. The locator stop must be adjusted to accommodate the terminal series size, which is marked on the terminal insulation (.110, .187, or .250). Rotate the blue plastic locator stop until the series size number, appearing in the uppermost position, matches the terminal series size. Refer to Figure 3.

**NOTE** *If crimping a flag terminal, the locator stop does NOT need to be adjusted.*



4. Push the locator assembly away from the upper crimping die slightly and hold.
5. Insert terminal mating end, flat side facing locator, in the BACK side of the tool frame; center on the appropriate crimping chamber on the lower crimping die. Allow terminal to butt against locator stop. See Figure 3.

**NOTE** *For a flag terminal, flat side of wire barrel must face outward and mating end must seat on locator.*



6. Holding terminal in position, release locator assembly. Insert stripped wire into wire barrel until wire bottoms.

7. Hold wire in position and maintain light pressure. Then, squeeze tool frame handles together until ratchet releases.
8. Allow tool frame handles to open FULLY. Holding locator assembly in position, remove crimped terminal.
9. Check crimped terminal to ensure that the appropriate crimp dot code appears on the terminal (refer to Figure 1 for code listing). See Figure 4 for a properly crimped terminal with a crimp dot code.

**NOTE** *Flat terminals will not have a crimp dot code.*

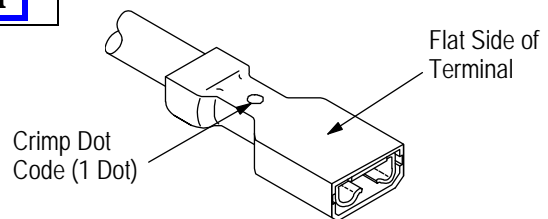

Figure 4

#### 5. MAINTENANCE AND INSPECTION PROCEDURE

TE recommends that a maintenance and inspection program be performed periodically to ensure dependable and uniform terminations. Though recommendations call for at least one inspection a month, frequency of inspection depends on:

1. The care, amount of use, and handling of the tool frame.
2. The presence of abnormal amounts of dust and dirt.
3. The degree of operator skill.
4. Your own established standards.

The tool frame is inspected before being shipped; however, TE recommends that the tool frame be inspected immediately upon arrival to ensure that it has not been damaged during shipment.

### 5.1. Daily Maintenance

1. Tool frame should be immersed (handles partially closed) in a reliable commercial degreasing compound to remove accumulated dirt, grease, and foreign matter. When degreasing compound is not available, tool frame may be wiped clean with a soft, lint-free cloth. Do NOT use hard or abrasive objects that could damage the tool frame.
2. Make certain that the retaining pins are in place and that they are secured with retaining rings.
3. All pins, pivot points, and bearing surfaces should be protected with a THIN coat of any good SAE 20 motor oil. Do not oil excessively.
4. When the tool frame is not in use, keep handles closed and store in a clean, dry area.

### 5.2. Periodic Inspection

#### A. Lubrication

Lubricate all pins, pivot points, and bearing surfaces with SAE 20 motor oil as follows:

- Tool frames used in daily production-lubricate daily
- Tool frames used daily (occasional)-lubricate weekly
- Tool frames used weekly-lubricate monthly

Wipe excess oil from tool frame. Oil transferred onto certain terminations may affect the electrical characteristics of an application.

#### B. Visual Inspection

1. Close tool frame handles until ratchet releases and then allow them to open freely. If they do not open quickly and fully, the spring is defective and must be replaced. See Section 6, REPLACEMENT AND REPAIR.
2. Inspect jaw platforms for worn, cracked, or broken areas. If damage is evident, return the tool frame to TE for evaluation and repair. See Section 6, REPLACEMENT AND REPAIR.

#### C. Ratchet Inspection

The ratchet feature on tool frames should be checked to ensure that the ratchet does not release prematurely, allowing the dies to open before they have fully bottomed.

1. Squeeze tool frame handles together and count the number of ratchet stops. Five stops, including the release position, should be indicated by the movement of the ratchet pawl and the clicking sound associated with its movement.
2. If fewer positions are indicated, the ratchet handle and ratchet pawl must be replaced. Refer to Section 6, REPLACEMENT AND REPAIR.
3. Recheck the ratchet. If second inspection reveals a continuing defect, return the tool frame to TE for evaluation and repair. Refer to Section 6, REPLACEMENT AND REPAIR.

When tool frame passes ratchet inspection, lubricate it with a THIN coat of any good SAE 20 motor oil.

### 6. REPLACEMENT AND REPAIR

The parts listed in Figure 5 are customer- replaceable. A complete inventory can be stocked and controlled to prevent lost time when replacement of parts is necessary. Parts other than those listed should be replaced by TE to ensure quality and reliability of the tool frame.

Order replacement parts through your TE Representative, or call 1-800-526-5142, or send a facsimile of your purchase order to 717-986-7605, or write to:

CUSTOMER SERVICE (038-035)  
TYCO ELECTRONICS CORPORATION  
PO BOX 3608  
HARRISBURG PA 17105-3608

Tools may also be returned to TE for evaluation and repair. For tool repair service, contact a TE Representative at: 1-800-526-5136.

### 7. REVISION SUMMARY

- Updated document to corporate requirements
- Changed ratchet pawl in Figures 1 and 5
- Changed information in table in Figure 5

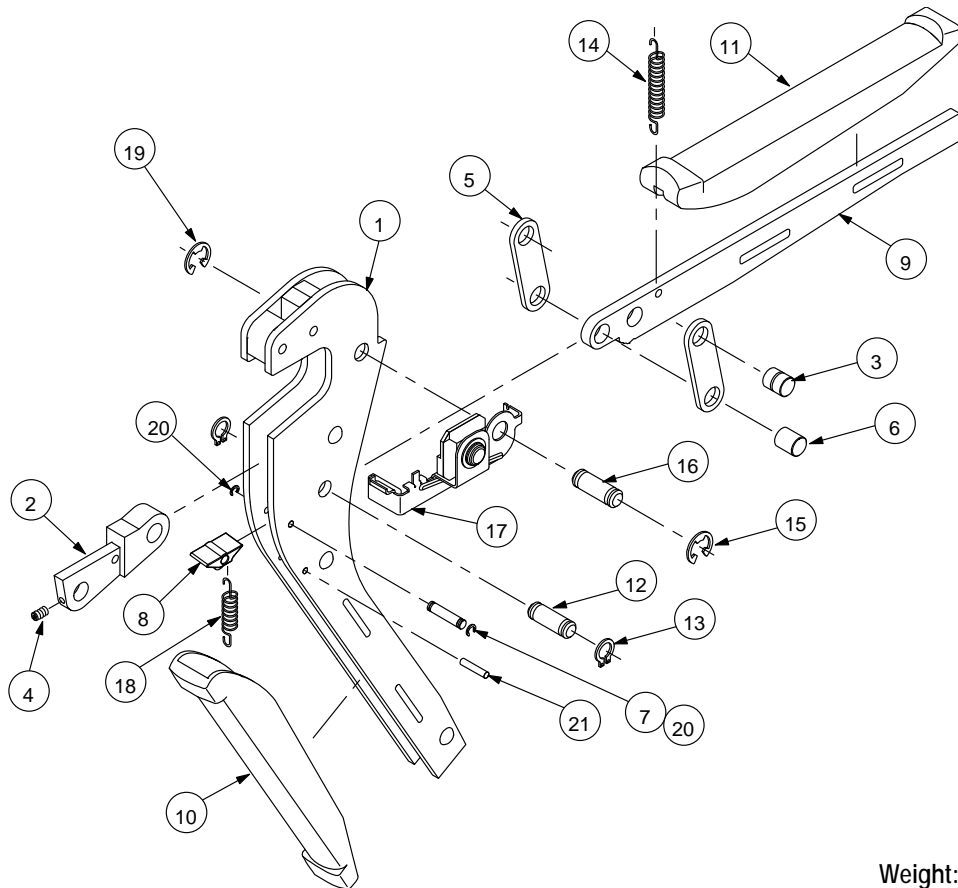

Weight: 595 g [1 lb, 5 oz.]

ITEM	PART NUMBER	DESCRIPTION	QTY PER ASSY
1	354098-4	FRAME, Handle	1
2	310952-2	JAW, Platform	1
3	310577-1	PIN, Toggle Link	1
4	21061-1	SETSCREW, Socket Head	2
5	310578-1	TOGGLE, Link	2
6	313033-2	PIN	1
7	9-59558-0	PIN, Grooved	1
8	1583388-1	PAWL, Ratchet	1
9	310582-1	HANDLE, Ratchet	1
10	354256-1	HANDLE, Plastic	1
11	310575-1	HANDLE, Plastic	1
12	7-59558-8	PIN, Handle, Pivot	1
13	1-21116-0	RING, Retaining	2
14	354266-1	SPRING, Extension	1
15	18202-1	E-RING, Bowed	1
16	7-59558-9	PIN, Pivot	1
17	312388-1	LOCATOR, Assembly	1
18	310690-1	SPRING, Extension	1
19	1-21113-6	E-RING, External	1
20	21045-1	RING, Retaining	2
21	3-21028-8	PIN, Slotted, .094D x .063 L	1

Figure 5