

UNIVAL[®] FUSE BLADE TYPE

BASIC TECHNICAL DATA

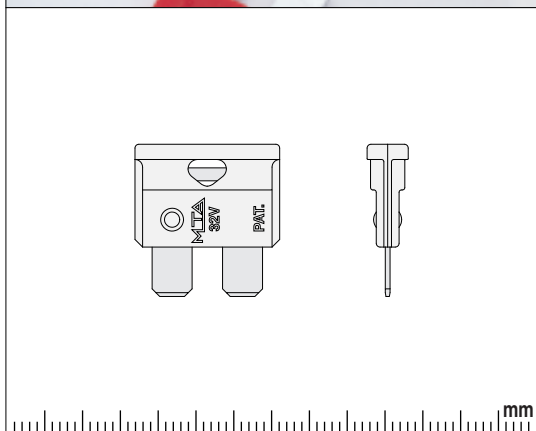

ISO 8820

DESCRIPTION

MTA **UNIVAL**[®] is the final result of the study and the tests performed by our technical department in order to obtain a high quality protection device for automotive application.

This fuse is designed to interrupt electrical short circuits or prescribed overload current. The correspondence between current intensity and time complies with international standard reference (see the curves for details).

This fuse device presents very good characteristics of reliability, mounting and substitution in maintenance operations and the production process guarantees high level in standard performances of the product.

Owing to these characteristics the **UNIVAL**[®] fuses are used by the most important car builders in the world.

USE

The blade fuse is designed to protect electrical and electronic circuits of vehicles and other devices fed with DC voltage, with mounting in fuseholders, mainboxes or other application boxes.

The object performs correct protection with a maximum voltage of 32 Vdc.

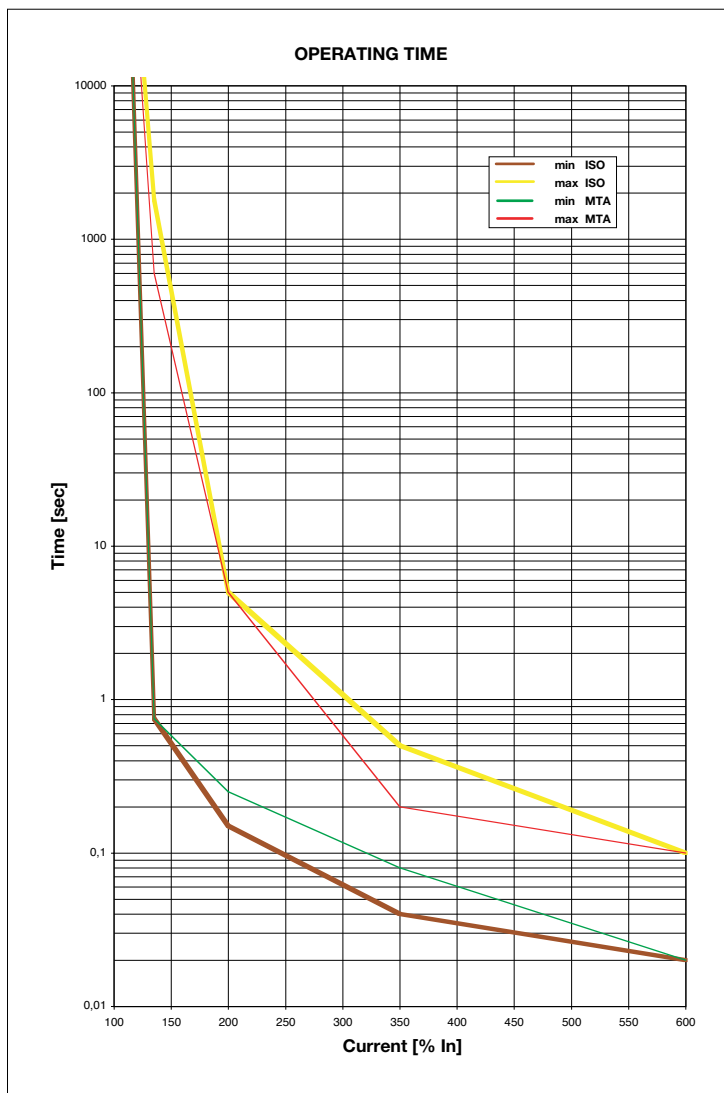

Rated current I_n [A]	Case colors	Max voltage drop c.d.t. * [mV]	Overload $I = 110\% I_n$ ** [h]	Residual resistance after blow $V_I = 500 V_{cc}$ ** [Mohm]
2		200	> 100	> 1
3		175	> 100	> 1
4		175	> 100	> 1
5		150	> 100	> 1
7,5		150	> 100	> 1
10		125	> 100	> 1
15		125	> 100	> 1
20		100	> 100	> 1
25		100	> 100	> 1
30		95	> 100	> 1

* Carry out after 15', ambient temperature

** ambient temperature: 23 ±5 °C

UNIVAL[®] FUSE BLADE TYPE

BASIC TECHNICAL DATA

DERATING CURVE

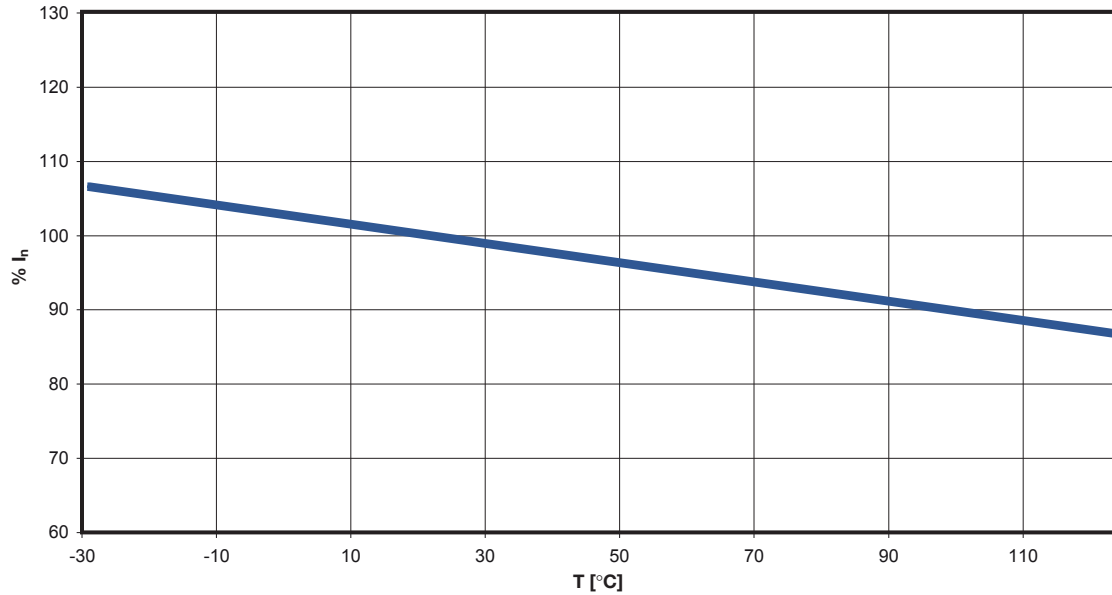

EXPECTED MELTING TIME VS CURRENT CURVES
AMBIENT TEMPERATURE 23°C

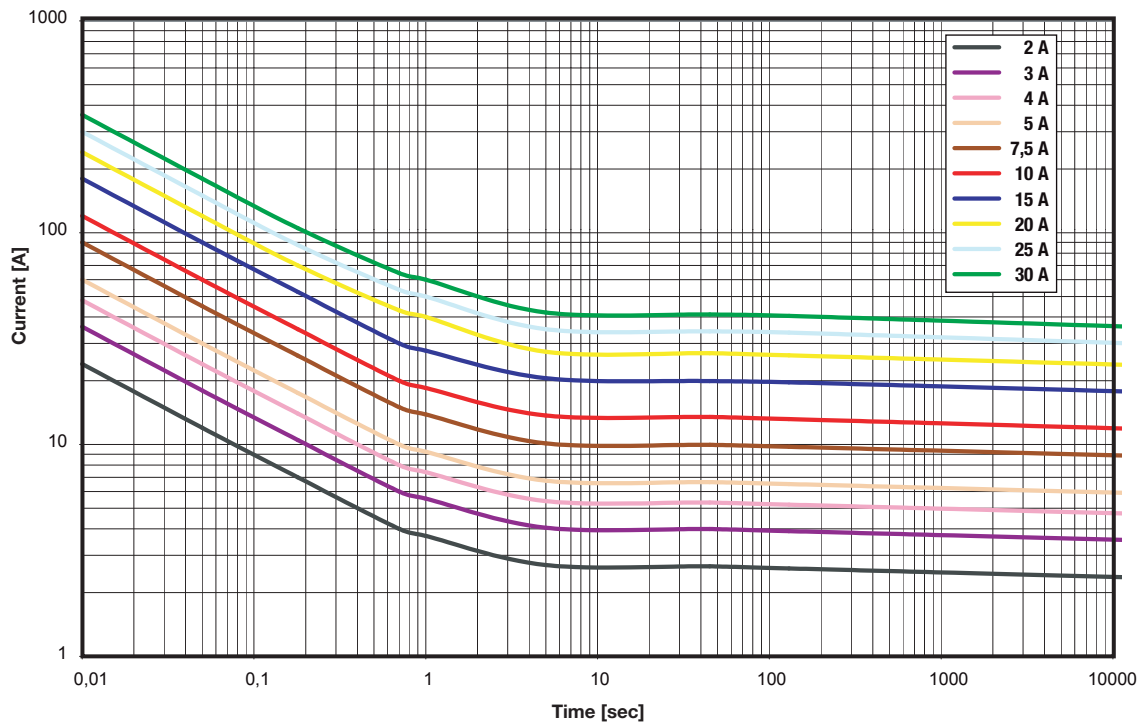

DRAWINGS, SPECIFICATIONS AND REFERENCE NUMBERS MAY BE MODIFIED AND CHANGED. MTA S.p.A. RESERVES ITSELF THE RIGHT, TO MAKE CHANGES FOR TECHNICAL OR QUALITY IMPROVEMENTS, WITHOUT ANY NOTICE.

COMPANY WITH QUALITY SYSTEM
CERTIFIED BY DNV
ISO 9001/QS 9000

COMPANY WITH ENVIRONMENTAL MANAGEMENT
SYSTEM CERTIFIED BY DNV
ISO 14001