

# Ammeter

842052

1

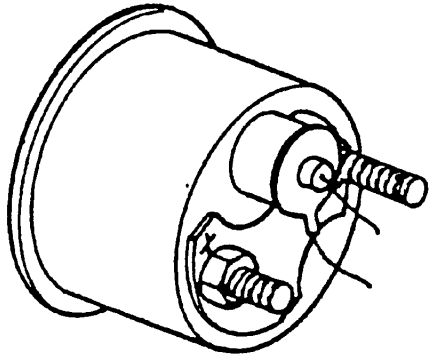

2

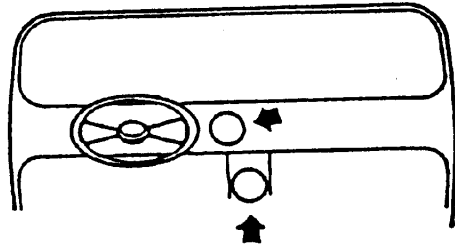

3

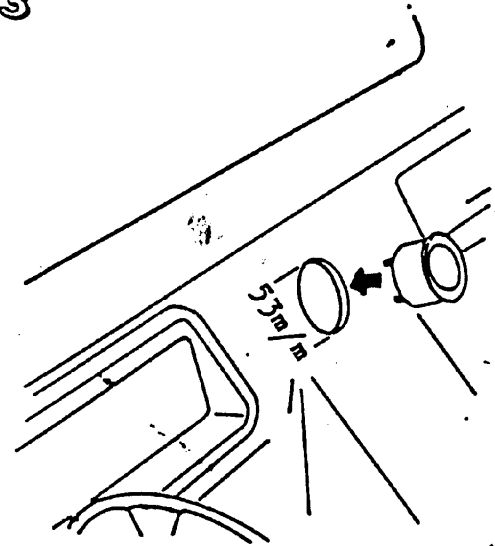

4

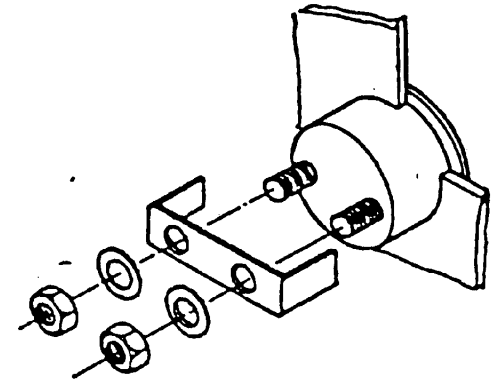

5

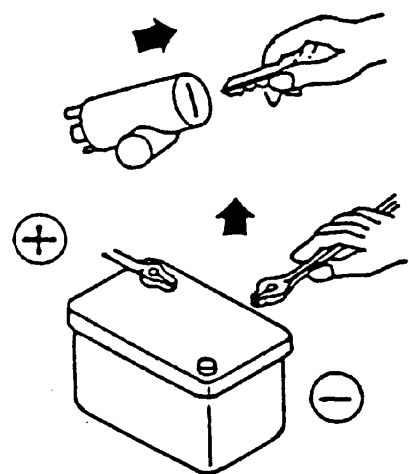

6

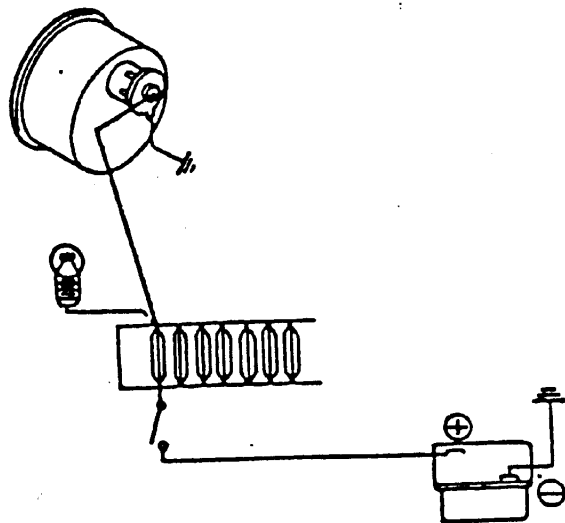

7

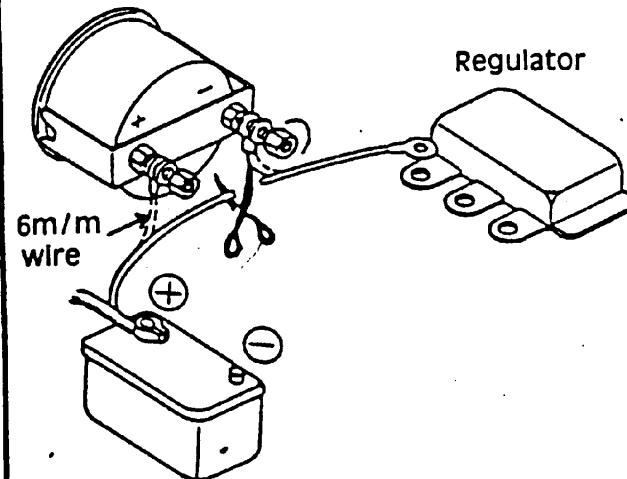

8

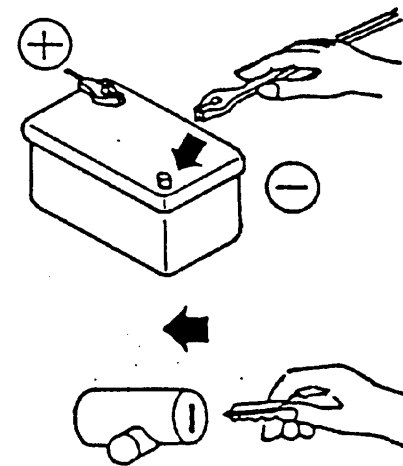

# Cockpit System

Optiona

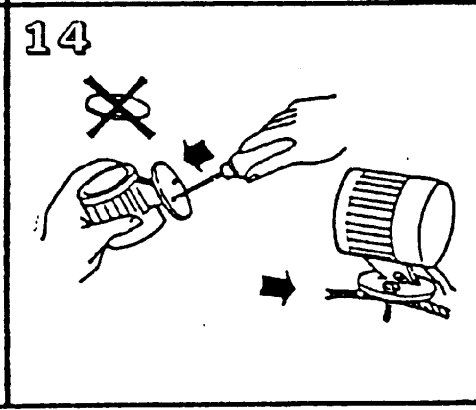
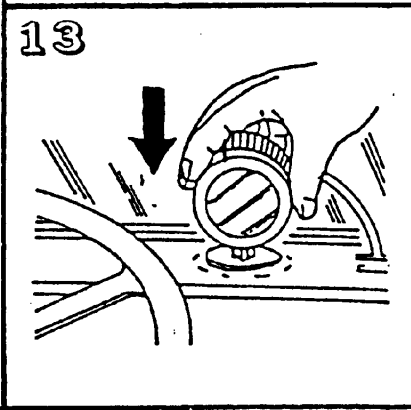
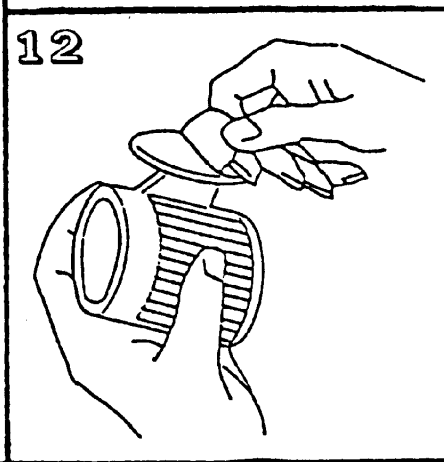
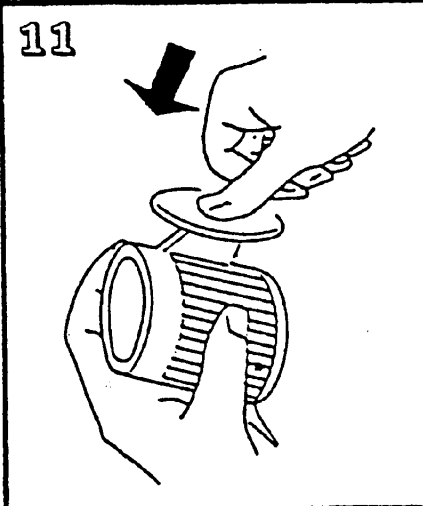
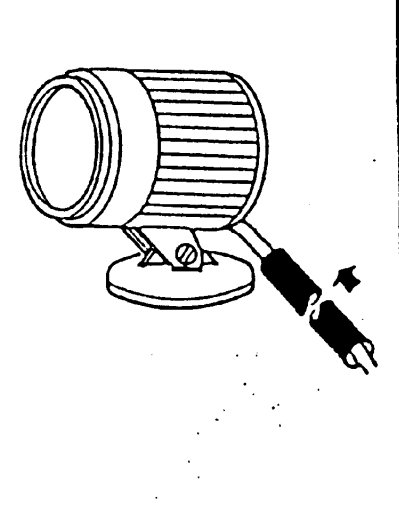
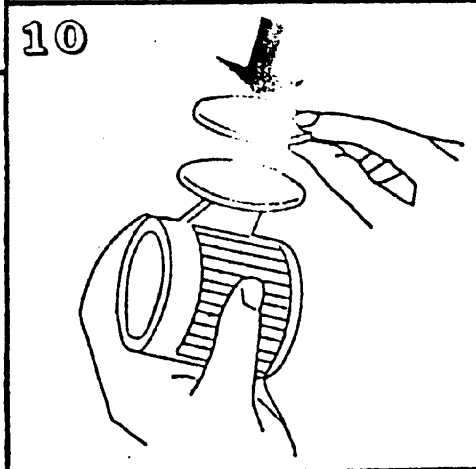
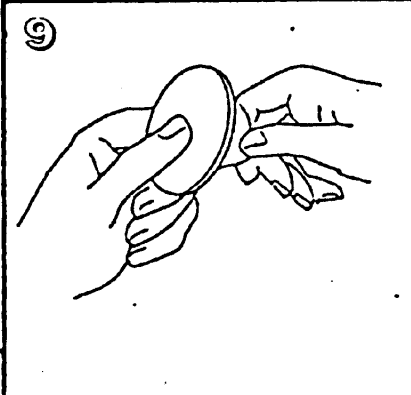
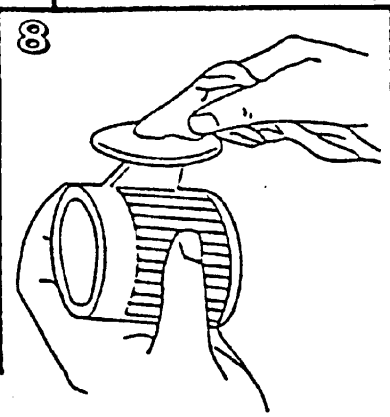
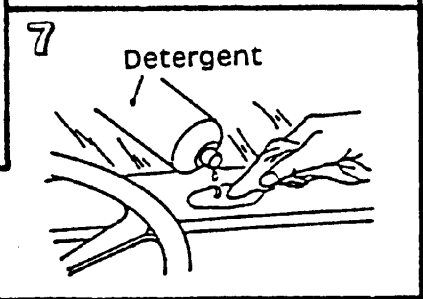
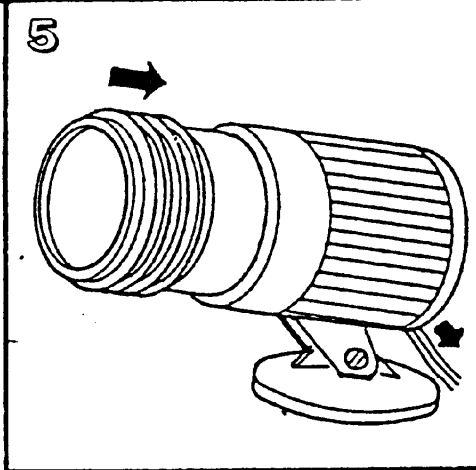
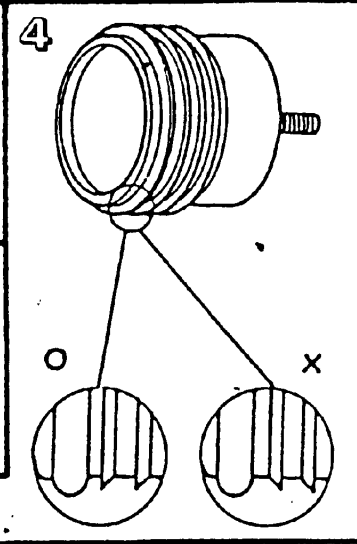
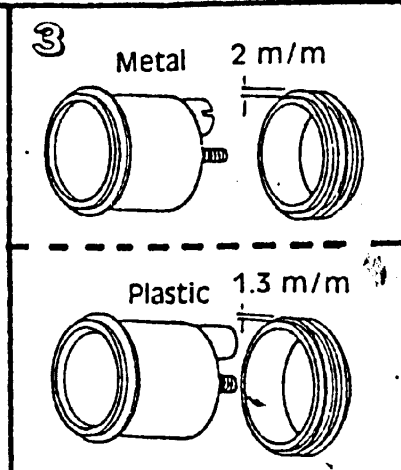
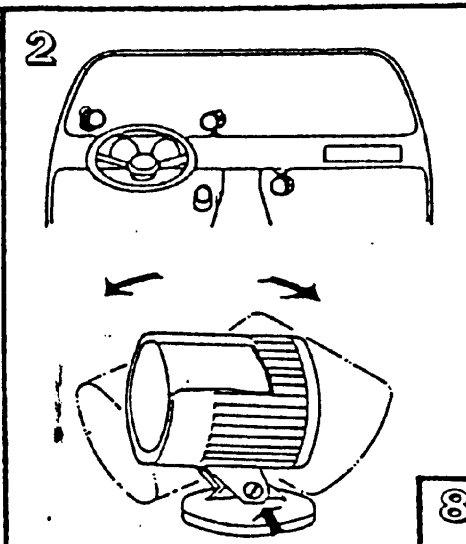
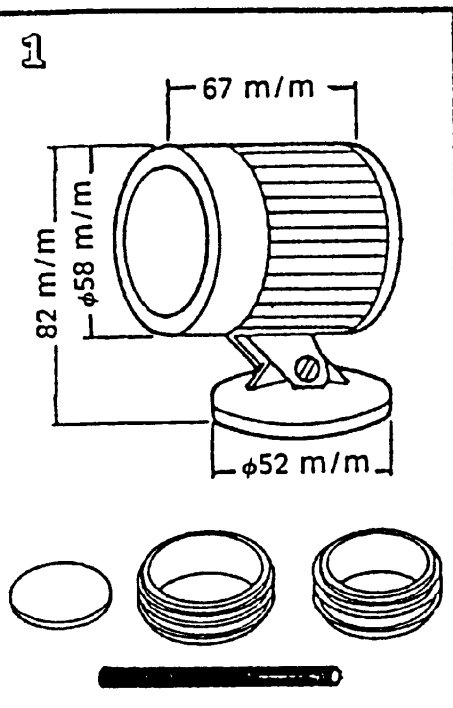

## 1 INTRODUCTION

**AMMETER:** Some gauge kits are equipped with an ammeter. See Section 3, Ammeter Connection, for proper connection procedures for ammeter gauges.

## 2 MOUNTING AND INSTALLATION

**NOTE:** For information on optional mounting configurations and mounting hardware, visit us on the web at [www.iequus.com](http://www.iequus.com)

### A. PANEL INSTALLATION

For On-Dash or Under-Dash mounting (panels are optional with some gauge models and must be purchased separately).

1. Determine mounting location (see section 1, step 7).
2. Using gauge panel as a template, mark locations for screws.
3. Drill small holes for the screws.
4. Mount panel in place and secure with screws and flat washers provided.



Figure 1. Gauge Panel

### B. IN-DASH MOUNTING

1. Using a hole template, cut out a 1-1/2", 2" or 2-5/8" (3.81 cm, 5.08 cm, or 6.67 cm) hole, as necessary, through the dashboard.
2. Using a round file, smooth out the rough edges around the drilled hole.

### C. INSTALLING GAUGE INTO GAUGE PANEL OR IN-DASH

1. Insert gauge through front of panel or hole in dashboard, as applicable.
2. Hold gauge case and rotate gauge, as needed, until gauge dial face is properly positioned in front of dashboard/panel. Secure gauge in place.
3. Tighten locking ring on gauge in clockwise direction until gauge is tight against dashboard/panel. Tighten locking ring **HAND TIGHT ONLY**.

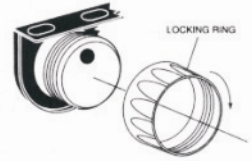

Figure 2. Gauge Equipped with Locking Ring

## 3 GAUGE LIGHT INSTALLATION AND CONNECTION

**NOTE:** Depending on the model of gauge, backlighting color may be changed to either red, green or blue by installing the optional color filter over the bulb (not available for all gauge kits).

1. Insert the light bulb and socket assemblies into the light receptacles on the back of the gauge and press firmly to snap/lock into place.

**NOTE:** Wire for gauge lights must be purchased separately. Use size 18-20 AWG stranded copper wire.

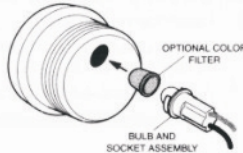

Figure 3. Light Bulb Installation

2. Splice the RED or WHITE wire from the gauge light(s) into the vehicle's lighting circuit, between the dimmer control switch and the dash lights (consult the vehicle's service manual for proper wire).
3. Connect light socket BLACK wire to a good chassis ground.
4. Insulate all connections with shrink tubing to prevent shorting.

**WARNING:** For bulb replacement use only part # 161 Instrument/Indicator wedge type bulbs available at most auto parts stores. **DO NOT USE ANY OTHER PART NUMBER SINCE THE HEAT PRODUCED BY A HIGHER WATTAGE BULB WILL MELT THE GAUGE CASE AND CREATE A FIRE HAZARD.**

## 4 AMMETER CONNECTION

**WARNING:** Make sure the maximum capacity of your charging system does not exceed the ammeter's dialface capabilities.

**NOTE:** We strongly recommend professional installation or assistance when installing an ammeter.

1. Determine routing for ammeter wiring. Use an existing firewall grommet, or drill a hole through firewall to accommodate wires. Install a rubber grommet (purchased separately) in hole, use shrink tubing, or wrap with electrical tape to protect wiring from chaffing or other damage.

**NOTE:** Ammeter wiring must be purchased separately. Use 10 AWG wire minimum.

2. Crimp or solder ring terminals (purchased separately) on ammeter positive (+) and negative (-) wires. Connect wires to ammeter using two nuts and flat washers. **TIGHTEN NUTS SECURELY. PROPERLY INSULATE ALL CONNECTIONS.**



**NOTE:** This is an "in-line" attachment gauge. NEVER GROUND GAUGE STUDS OR WIRES.

3. Route wiring through grommet in firewall.
4. Connect ammeter wiring to charging system:

- For magnetic starter switch systems (Ford/Chrysler), see Wiring Diagram A. Remove nut and washer from starter solenoid switch battery connection post "A". Remove all wires except wire going to battery. Connect ammeter positive (+) lead to post "A"; reinstall washer and nut. Connect ammeter negative (-) wire to wire(s) removed from post "A" using screw, lockwasher, and nut (purchased separately).
- Insulate terminal lug connection using shrink tubing or electrical tape to prevent shorting.

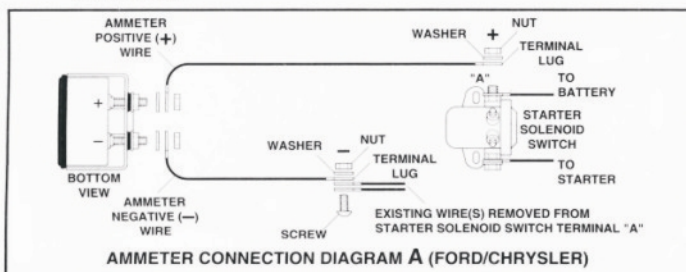

- For voltage regulator/horn relay circuit systems (GM/Chrysler) see Wiring Diagram B. Splice ammeter positive (+) and negative (-) wires into wire from battery positive (+) to voltage regulator.

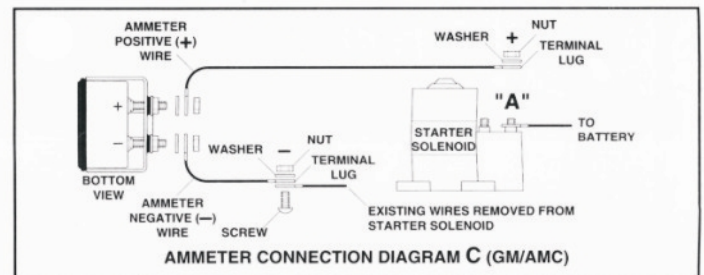

- For most starter solenoid circuits (GM/AMC), see Wiring Diagram C. Remove nut and washer from starter solenoid battery connection post "A". Remove all wires except wire going to battery. Connect ammeter positive (+) wire to post "A"; reinstall washer and nut. Connect ammeter negative (-) wire to wires removed from post "A" using screw, lockwasher, and nut (purchased separately).

- Insulate terminal lug connection using shrink tubing or electrical tape to prevent shorting.

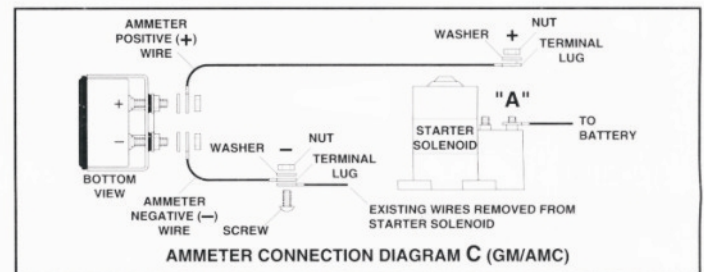

5. Reconnect negative (-) battery cable. Turn on headlights and observe ammeter. Ammeter should indicate "-". If ammeter reads backwards, reverse the positive (+) and negative (-) connections. If ammeter fails to read, turn off headlights and recheck connections.

**NOTE:** If none of the diagrams matches your vehicle's system, consult your vehicle's service manual or a qualified mechanic.