

# Housing - SCT-D-SUB 15-KG - 2749563

Please be informed that the data shown in this PDF Document is generated from our Online Catalog. Please find the complete data in the user's documentation. Our General Terms of Use for Downloads are valid (<http://download.phoenixcontact.com>)



POWER-SUBCON cable housing, 5-pos.

## Key commercial data

<b>package_quantity</b>	1
<b>GTIN</b>	4017918104986

## Technical data

### General

<b>Number of positions</b>	5
----------------------------	---

## classifications

### eCl@ss

<b>eCl@ss 4.0</b>	27140201
<b>eCl@ss 4.1</b>	27130801
<b>eCl@ss 5.0</b>	27130801
<b>eCl@ss 5.1</b>	27130801
<b>eCl@ss 6.0</b>	27130807
<b>eCl@ss 7.0</b>	27130807
<b>eCl@ss 8.0</b>	27130807

### ETIM

<b>ETIM 2.0</b>	EC000943
<b>ETIM 3.0</b>	EC000943
<b>ETIM 4.0</b>	EC000437
<b>ETIM 5.0</b>	EC000943

### UNSPSC

<b>UNSPSC 6.01</b>	30212010
<b>UNSPSC 7.0901</b>	39121610
<b>UNSPSC 11</b>	39121610
<b>UNSPSC 12.01</b>	39121610
<b>UNSPSC 13.2</b>	39121620

# Housing - SCT-D-SUB 15-KG - 2749563

## Drawings

Dimensioned drawing

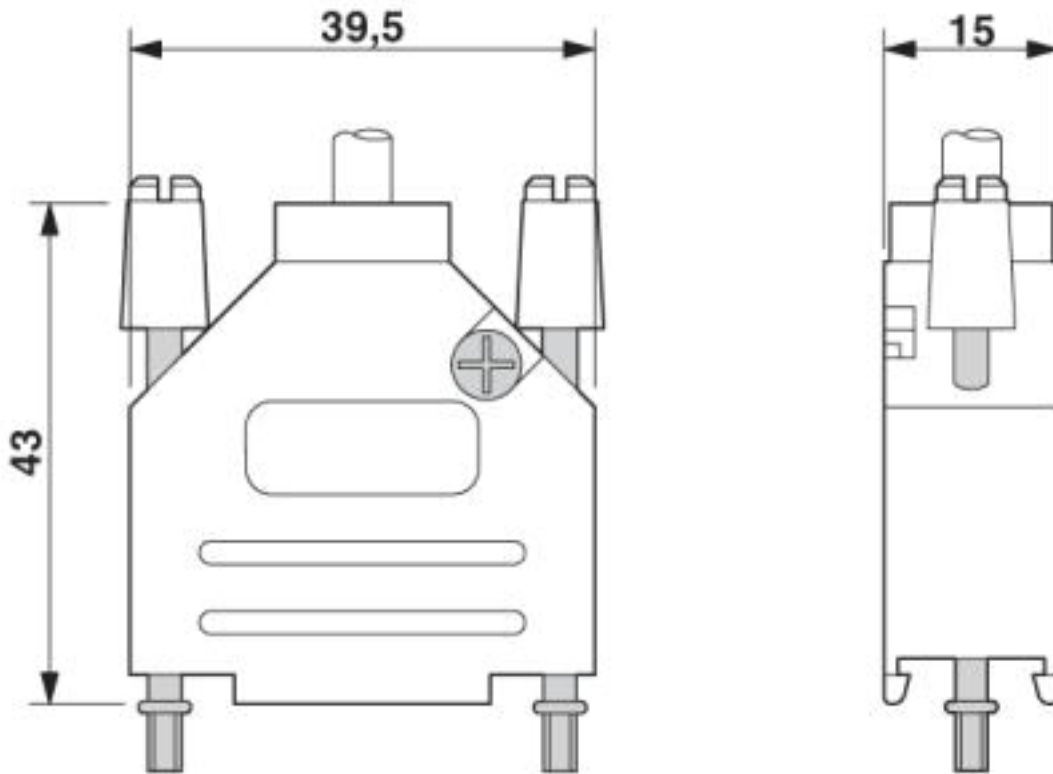

© Phoenix Contact 2013 - all rights reserved  
<http://www.phoenixcontact.com>