

1

2

3

4

5

6

7

Signature	Revision History	Date	Rev.
Alex.Dan	For Bulk Production	Dec.20.2005	01

DB 25M  
PLASTIC:BLUE

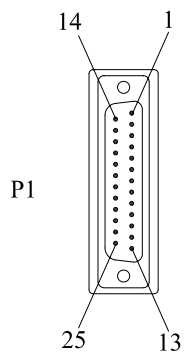

P1

L=2000±50mm

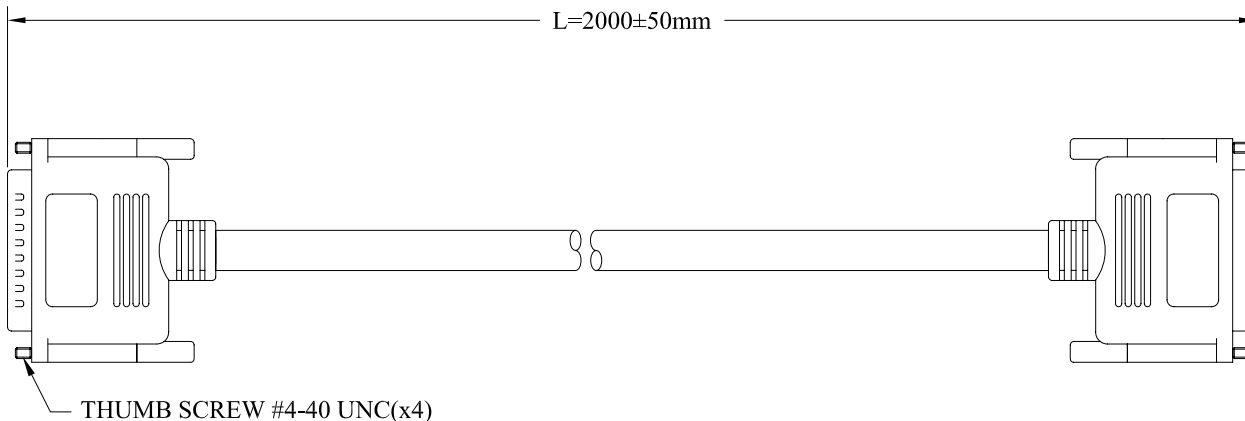

THUMB SCREW #4-40 UNC(x4)

DB 25F  
PLASTIC:BLUE

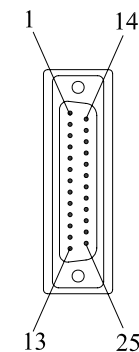

P2

NOTES:

- CABLE:28AWG(7/0.127 T.C)\*25C INSULATION:PVC+DRAIN WIRE+AL/MYLAR+JACKET PVC COLOR:BEIGE.  
OD:Ø7.0±0.2mm NON-UL
- CONNECTOR:  
P1:DB 25P MALE,GOLD FLASH CONTACT,NICKEL PLATED SHELL  
P2:DB 25P FEMALE,GOLD FLASH CONTACT,NICKEL PLATED SHELL
- HOOD:MOLDED TYPE,PVC 45P,COLOR:BEIGE.
- ELECTRICAL TEST:  
<1>.100% OPEN SHORT & MIS WIRE TEST  
<2>.CONTACT RESISTANCE 3 OHMS MAX.  
<3>.INSULATION RESISTANCE 20M OHMS MIN.
- PACKING:SEE P-0039 REV.C PACKING DRAWING  
PACKING TYPE: DB VP4.  
(HANKING SIZE MUST BE SMALLER THAN PACKING)

		PIN OUT																																						
P1	1	2	3	4	5	6	7	8	9	10	11	12	13	14																										
P2	1	2	3	4	5	6	7	8	9	10	11	12	13	14	15	16	17	18	19	20	21	22	23	24	25	SHELL														
																												15	16	17	18	19	20	21	22	23	24	25	SHELL	

RoHS Compliant

EAN Code:  
4016032062707

		Date	Name	Part No.  <b>AK 135 2M</b>	
Drawn by	Dec.20,2005	Alex Dan			
Checked by	Dec.20,2005	Norman Xu			
Approved by			Title. <b>DB25/M-DB25/F CABLE,2M</b>		
<b>ASSMANN</b> Electronic GmbH			Scale	N/A	Sheet
			Unit	MM	1/1

ST81407

1

2

3

4

5

6

7