

Product Spec. Sheet

Diamond Series- 2Joint Spring Arm Grommet+C-Clamp Type (2 in 1Type) (702mm)Steel Pole
 EM75159-29156c6 2 in 1 (C-Clamp + Grommet) Desk Mount LCD Monitor Arm



Product Name	Diamond Series 6 Monitors /2 Joint Spring Arm
Model Number (color)	EM75159(Silver Grey)
Product Includes	Spring Arm x 6,Swivel Arm x 4,Dual Stand x 2, 2 In 1 (C-Clamp + Grommet) Desk Mount Base, Monitor Bracket x 6
Attachment Options	 Lock for Security
Product Dimension.	Product : L900xW350xH1100mm Weight:20kg White Box : non
Units per Master Carton	1pcs
Shipping Master Carton Dimens.	Carton : L885x W270xHx465mm
Shipping Weight	N.W.:20Kg G.W.:21Kg
Units per Pallet	16pcs
Warranty	12 Months
Weight Capacity	≤ 45kg(100lbs) almost any VESA compliant monitor up to 19"
Country of Origin	Taiwan

Features

1. Elegant, Stylish and Ergonomic design with high performance
2. Wide Angle and height range for comfortable view position.
3. Swift Movement with easy adjustment.
4. 3 quick mode release function as Pivot stand, Swivel or Spring Arm.
5. Easily do install and dismount.
6. Aluminum alloy and metal material, strong and safety.
7. Internal cable management routed cables neatly under arm.
8. Space saving.
9. A considerate Tool fixed design, no more worrying tool of placement.
10. VESA MIS-D 75x75/100x100mm

Tech Specs

									
VESA	LIFT	ANGLE	PIVOT	SWIVEL	PAN	TILT	EXTENSIO	VERTICAL	Wt.Load
	440mm	100°	360°	360°	240°	105°	540mm	270mm	≤45kg

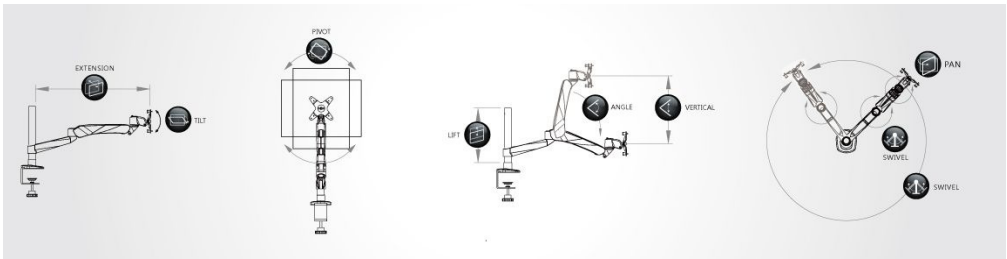

Drawing

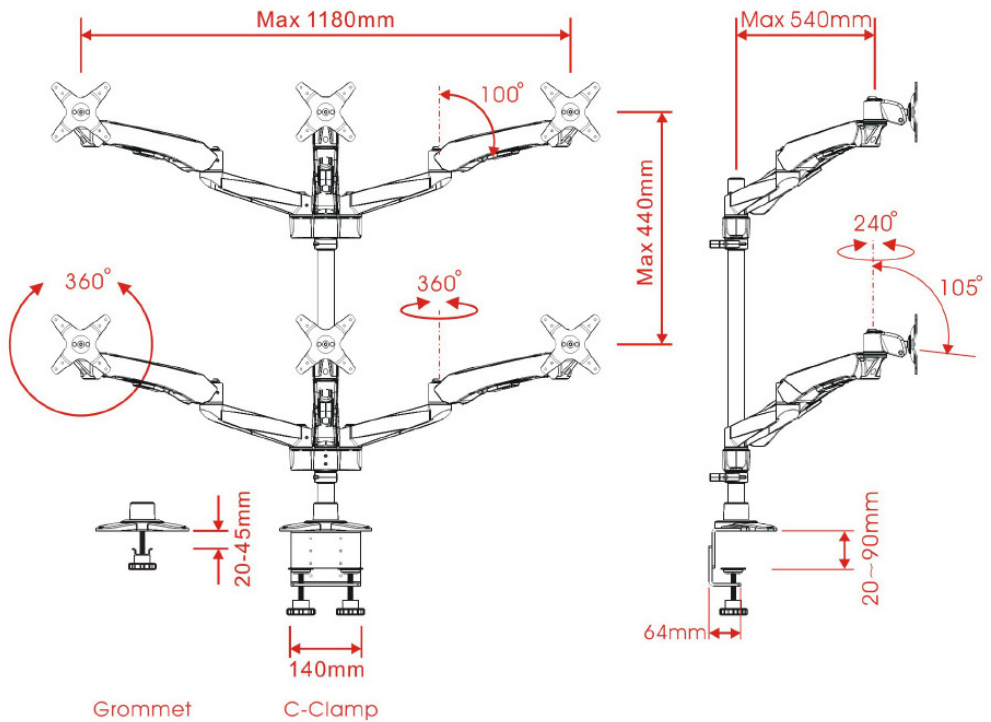

4 & ABOVE MONITORS ARM USER'S MANUAL

(4與6螢幕支架使用手冊)

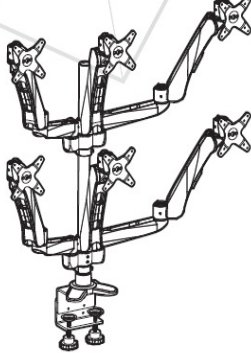

71H016163-001

1 4 Monitor Arm Installation (4螢幕支架安裝方法)

Step 1
Assemble Cable Clip and Dual Stand Step by Step
依序安裝理線環及分支座

Step 2
Assemble 4 Swivels on to 2 Dual Stands
安裝四支延伸臂於分支座上

Step 3
Assemble 4 Spring Arms on to 4 Swivels
安裝四支彈簧臂於延伸臂上

Step 4
Assemble 4 Monitor Brackets on to 4 Spring Arms
安裝四個螢幕支撐架於彈簧臂上

Step 5
Assemble 4 Swivel Arms on to 4 Swivel Arms
安裝四支延伸臂於延伸臂上

Step 6
Assemble 4 Monitor Brackets on to 4 Swivel Arms
安裝四個螢幕支撐架於延伸臂上

Adjust to the suitable height then turn the wrench to fix. (調整適合高度，然後用M3六角螺絲安裝)

Use M3 wrench to tighten or loosen swing feeding. (用M3六角螺絲調整或放鬆旋轉的鬆緊)

Place wrench into the hole to prevent the tool of alignment. (把六角螺絲放在孔內，防止偏斜)

Use M3 wrench to tighten or loosen swing feeding. (用M3六角螺絲調整或放鬆旋轉的鬆緊)

Use M3 wrench to tighten or loosen swing feeding. (用M3六角螺絲調整或放鬆旋轉的鬆緊)

2 6 Monitor Arm Installation (6螢幕支架安裝方法)

Step 1
Assemble Cable Clip, Dual Stand, Monitor Bracket Step by Step
依序安裝理線環、分支座及螢幕支撐架

Step 2
Assemble 4 Swivels on to 2 Dual Stands
安裝四支延伸臂於分支座上

Step 3
Assemble 4 Swivels on to 4 Swivels
安裝四支延伸臂於延伸臂上

Step 4
Assemble 4 Spring Arms on to 4 Swivels
安裝四支彈簧臂於延伸臂上

Step 5
Assemble 4 Monitor Brackets on to 4 Spring Arms
安裝四個螢幕支撐架於彈簧臂上

Step 6
Assemble 4 Swivel Arms on to 4 Swivel Arms
安裝四支延伸臂於延伸臂上

Step 7
Assemble 4 Monitor Brackets on to 4 Swivel Arms
安裝四個螢幕支撐架於延伸臂上

Adjust to the suitable height then turn the wrench to fix. (調整適合高度，然後用M3六角螺絲安裝)

Use M3 wrench to tighten or loosen swing feeding. (用M3六角螺絲調整或放鬆旋轉的鬆緊)

Place wrench into the hole to prevent the tool of alignment. (把六角螺絲放在孔內，防止偏斜)

Use M3 wrench to tighten or loosen swing feeding. (用M3六角螺絲調整或放鬆旋轉的鬆緊)

Use M3 wrench to tighten or loosen swing feeding. (用M3六角螺絲調整或放鬆旋轉的鬆緊)

Use M3 wrench to tighten or loosen swing feeding. (用M3六角螺絲調整或放鬆旋轉的鬆緊)

Use M3 wrench to tighten or loosen swing feeding. (用M3六角螺絲調整或放鬆旋轉的鬆緊)

3 6 Monitor Arm Installation (6螢幕支架安裝方法)

Step 1
Assemble Cable Clip, Dual Stand and Spring Arm Step by Step
依序安裝理線環、分支座及彈簧支撐架

Step 2
Assemble 4 Swivels on to 2 Dual Stands
安裝四支延伸臂於分支座上

Step 3
Assemble 4 Spring Arms on to 4 Swivels
安裝四支彈簧臂於延伸臂上

Step 4
Assemble 6 Monitor Brackets on to 4 Spring Arms
安裝六個螢幕支撐架於彈簧臂上

Adjust to the suitable height then turn the wrench to fix. (調整適合高度，然後用M3六角螺絲安裝)

Use M3 wrench to tighten or loosen swing feeding. (用M3六角螺絲調整或放鬆旋轉的鬆緊)

Place wrench into the hole to prevent the tool of alignment. (把六角螺絲放在孔內，防止偏斜)

Use M3 wrench to tighten or loosen swing feeding. (用M3六角螺絲調整或放鬆旋轉的鬆緊)

Use M3 wrench to tighten or loosen swing feeding. (用M3六角螺絲調整或放鬆旋轉的鬆緊)

4 Install Monitors (安裝螢幕)

Monitor does not stop in place or movement is stiff. (Please use Wrench to increase or decrease tension until rotation is equal. (調整鬆緊的力直到旋轉是平衡的。請使用M3六角螺絲調整。))

Use M3 wrench to tighten or loosen swing feeding. (用M3六角螺絲調整或放鬆旋轉的鬆緊)

Use M3 wrench to tighten or loosen swing feeding. (用M3六角螺絲調整或放鬆旋轉的鬆緊)

[4 & ABOVE MONITOR ARM STAND USER'S MANUAL]

(加大型底座組裝說明書)

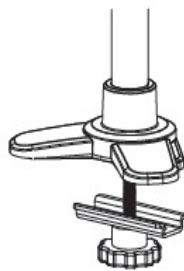

Parts kit (零件包)

C-Clamp Type Parts Kit C-Clamp 零件包

x1	x1	x1	x1	x1	x10
x4	x1				

Grummet Type Parts Kit Grummet 零件包

x1	x1	x1	x1	x1	x1
x4	x1	x4			

2 in 1 Type Parts Kit 2 in 1 零件包

x1	x1	x1	x1	x1	x1
x1	x10	x4	x1		

71H016175-004

1 C-Clamp Installation (C型夾安裝說明)

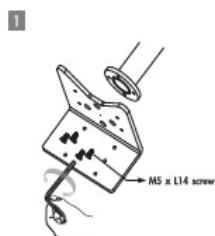

Combine Iron Pole with Upper Base
組合鐵桿與C-Clamp上基座。

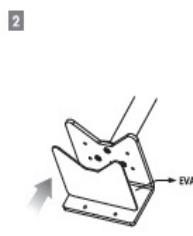

Stick EVA Pad to C-Clamp Upper Base to protect table surface.
將EVA墊片黏貼至C-Clamp上基座，保護桌面。

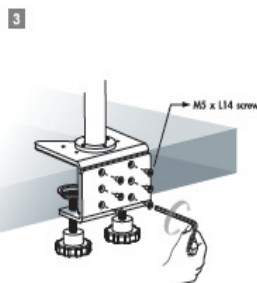

Measure the table thickness then adjust C-Clamp Base to suitable width.
量於桌面，並測量桌面厚度，量上C-CLAMP下基座。
(Notes1 註1)

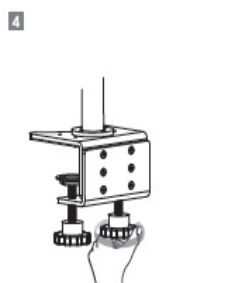

Rotating Hand Drive Screw clamp fixed on the desktop.
旋轉手旋螺絲，夾緊桌面固定完成。
(Notes2 註2)

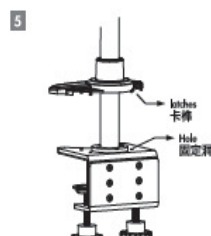

Set into the base decorated cover, and fixed into the hole through the latch, complete set up.
套進底座飾蓋，並將卡榫穿進固定洞內，完成組立。

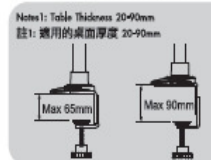

Notes1: Table Thickness 20-90mm
註1: 適用的桌面厚度 20-90mm

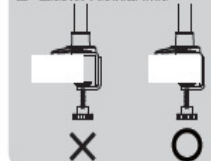

Notes2: Correct installation, C-Clamp must stop the table edge.
註2: 正確安裝C夾必須貼齊桌緣。

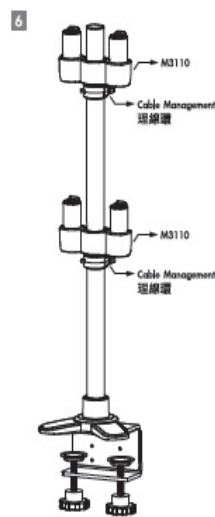

C-Clamp Type assembled complete.
C-Clamp Type 組裝完成。
M3110 is optional.
註3: M3110為選購配件。

2 Grommet Installation (穿桌型組裝說明)

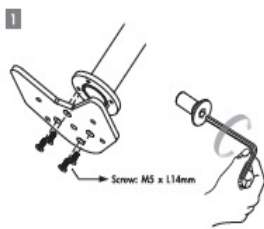

Combine Iron Pipe with Grommet base
組合鐵管與Grommet底座



Put decorative cover on base, latches must wear into the base of the fixed point.
將EVA裝飾蓋貼至底座，保證桌洞。
蓋上底座飾蓋，固定卡榫必須穿進底座上的固定點。



EVA pads adhesive to the base to protect the desktop.
將EVA黏貼至底座，保護桌面。



Set Grommet Clip on Hand Drive Screw
將Grommet夾片裝於手旋螺絲上。

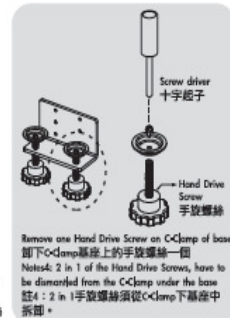

Remove one Hand Drive Screw on C-Clamp of base.
卸下C-Clamp底座上的手旋螺絲一個
Notes: 2 in 1 of the Hand Drive Screws, have to be dismantled from the C-Clamp under the base.
註4: 2 in 1手旋螺絲須從C-Clamp下底座中拆卸。

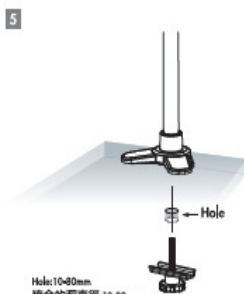

Hole: 10-40mm
鑿合的孔直徑: 10-40mm
Thickness: 20-45mm
可夾持的厚度: 20-45mm



The Hand Drive Screw and Grommet Clip from the bottom of the desktop through to Grommet module, tighten the fixed.
將手旋螺絲及Grommet夾片由桌面底部穿進Grommet底座裝緊固定。

Notes: Table Thickness 20-45mm
註1: 適用的桌面厚度 20-45mm



Correct assembly method
圖右為正確安裝方式

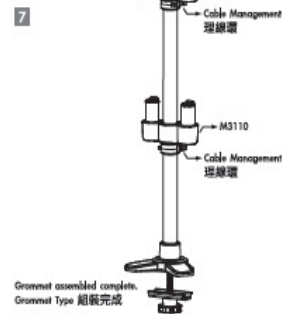

Grommet assembled complete.
Grommet Type 組裝完成
M3110 is optional.
註: M3110為選購配件。

3 Model Types (各機種樣式)

4 Monitors 4螢幕

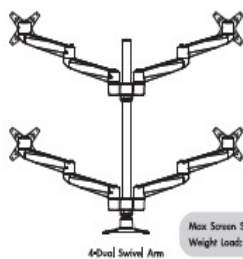

4-Dual Swivel Arm
Max Screen Size: 27 inch
Weight Load: total < 45kg

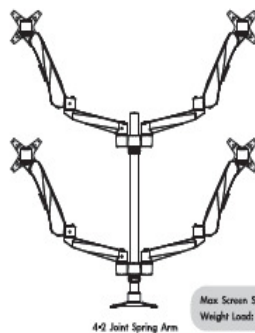

4-2 Joint Spring Arm
Max Screen Size: 27 inch
Weight Load: total < 45kg

6 Monitors 6螢幕

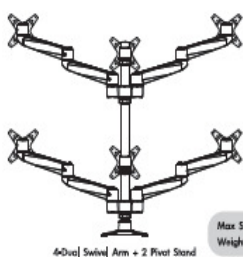

4-Dual Swivel Arm + 2 Pivot Stand
Max Screen Size: 19 inch
Weight Load: total < 45kg

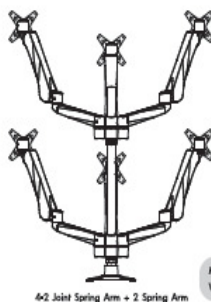

4-2 Joint Spring Arm + 2 Spring Arm
Max Screen Size: 19 inch
Weight Load: total < 45kg

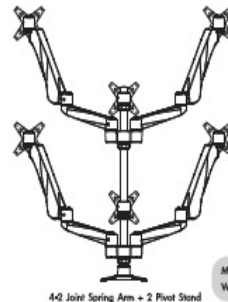

4-2 Joint Spring Arm + 2 Pivot Stand
Max Screen Size: 23 inch
Weight Load: total < 45kg

4 & Above Monitors Type

Model No.	Description
EM63156	4 Monitors
EM63151	4-Dual Swivel Arm
EM63159	Max Screen Size : 27 inch
EM65156	4 Monitors
EM65151	4-2 Joint Spring Arm
EM65159	Max Screen Size : 27 inch
EM73256	6 Monitors
EM73251	4-Dual Swivel Arm +
EM73259	2 Pivot Stand
EM75156	6 Monitors
EM75151	4-2 Joint Spring Arm +
EM75159	2 Spring Arm
EM75256	6 Monitors
EM75251	4-2 Joint Spring Arm +
EM75259	2 Pivot Stand
	Max Screen Size : 23 inch
	4 Swivel Arms