

# 242408 FPS

Shielded  
Lead-free solder

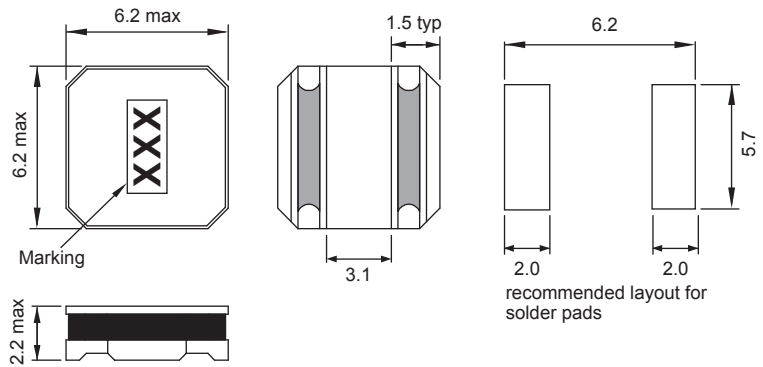

Typical Ls vs Frequency (f)

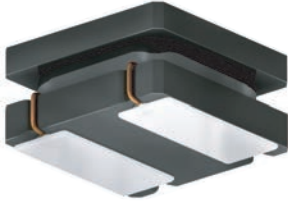
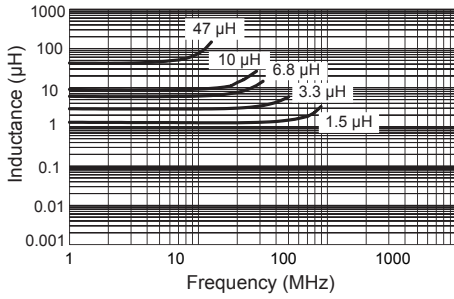

Typical Ls vs Current (I)

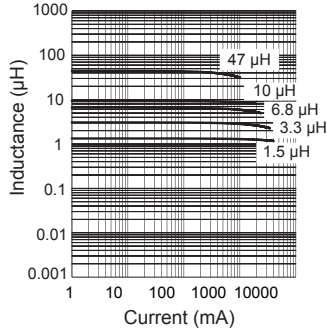

Part No	Inductance L (µH)	f <sub>L</sub> (kHz)	Tol ± (%)	DCR max (mΩ)	Rated DC Current I <sub>sat</sub> (A)	I <sub>rms</sub> (A)
242408FPS-R50N-01	0.5	100/1.0V	30	11.7	7	5.2
242408FPS-R80N-01	0.8	100/1.0V	30	15.6	6	4.1
242408FPS-1R5N-01	1.5	100/1.0V	30	22.1	4	3.6
242408FPS-2R2N-01	2.2	100/1.0V	30	31.2	3.5	2.9
242408FPS-3R3N-01	3.3	100/1.0V	30	39	2.8	2.8
242408FPS-4R7M-01	4.7	100/1.0V	20	52	2.4	2.2
242408FPS-5R6M-01	5.6	100/1.0V	20	66	2.2	2
242408FPS-6R8M-01	6.8	100/1.0V	20	72	2	1.8
242408FPS-100M-01	10	100/1.0V	20	108	1.9	1.5
242408FPS-150M-01	15	100/1.0V	20	144	1.3	1.2
242408FPS-220M-01	22	100/1.0V	20	204	1.1	1
242408FPS-330M-01	33	100/1.0V	20	372	0.9	0.9
242408FPS-470M-01	47	100/1.0V	20	444	0.8	0.8

Material : Ferrite

Revision date : 08 Oct 2013

SPQ : Reel 2000 [-01]