

U.I. Lapp GmbH	<h1>DATASHEET</h1>	
	EPIC® H-B 10 TBF	70040200 14.11.2013

Housing design H-B. The industry standard.
The smallest housing with single and double lever. The right housing is available for every application



Automation



Industrial machinery and plant engineering



Mechanical resistance



Robust



Waterproof

Info

Universal, robust metal housings size H-B 10

Application range

Plant engineering
Light & sound technology
Plastics industry

Product features

Cable coupler hood, low version
Dual levers
Straight cable entry
Versions with / without neck

Remark

Photographs are not to scale and do not represent detailed images of the respective products.

Technical Data

Article:	H-B 10 TBF 21
PG:	21
Neck:	yes
Pieces / PU:	10
Material:	Housing: powder-coated aluminium alloy, grey Lever: zinc-plated steel Sealing: NBR
Protection rating:	IP 65 (latched)
Temperature range:	-40 °C to +100 °C, short-term up to +125 °C

Product Management	Document: EPIC® H-B 10 TBF	1 / 2
--------------------	----------------------------	-------

U.I. Lapp GmbH	DATASHEET	 LAPP GROUP
	EPIC® H-B 10 TBF	70040200 14.11.2013

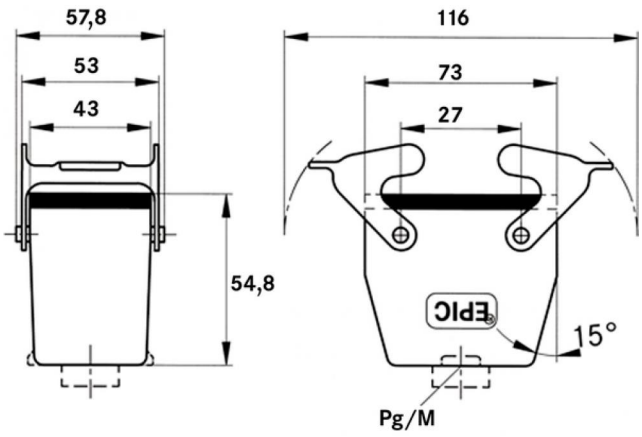

Product Management	Document: EPIC® H-B 10 TBF	2 / 2
--------------------	----------------------------	-------