

U.I. Lapp GmbH	DATASHEET	
	EPIC® H-B 24 TSB	10124000 14.11.2013

Housing design H-B. The industry standard.
Ideal for many applications due to a wide range of housings and inserts



Automation



Industrial machinery and plant engineering



Mechanical resistance



Robust



Waterproof



Info

Universal, robust metal housings size H-B 24

Application range

Plant engineering
Light & sound technology
Plastics industry

Product features

Hood, low version
Dual levers
Side cable entry
Versions with neck

Remark

Photographs are not to scale and do not represent detailed images of the respective products.

Technical Data

Article:	H-B 24 TSB 29
PG:	29
Neck:	yes
Pieces / PU:	5
Material:	Housing: powder-coated aluminium alloy, grey Lever: zinc-plated steel Sealing: NBR
Protection rating:	IP 65 (latched)
Temperature range:	-40 °C to +100 °C, short-term up to +125 °C

Product Management	Document: EPIC® H-B 24 TSB	1 / 2
--------------------	----------------------------	-------

U.I. Lapp GmbH	<h1>DATASHEET</h1>	 LAPP GROUP
	EPIC® H-B 24 TSB	10124000 14.11.2013

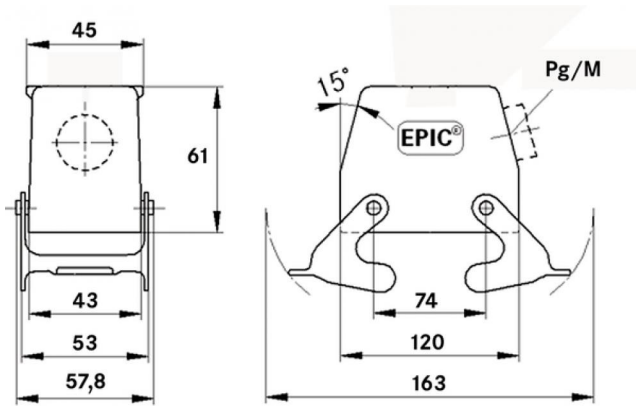

Product Management	Document: EPIC® H-B 24 TSB	2 / 2
--------------------	----------------------------	-------