

U.I. Lapp GmbH	<h1>DATASHEET</h1>	
	EPIC® ULTRA H-B 10 TS QB	70250211 14.11.2013

Housing H-B ULTRA: for higher functional reliability
 Optimum, low-resistance 360° screening
 All-purpose due to high corrosion resistance and high environmental protection.
 Space-saving due to compact dimensions
 Faster than any other comparable system
 High mechanical resistance



Good chemical resistance



Wide clamping range



Assembly time



Optimum strain relief



Space requirement



Robust



Integrated SKINTOP® cable gland



Connector with standard housing unit



Waterproof

Info

EMC protection
 Corrosion-resistant
 SKINTOP® integrated cable gland

Application range

In EMC-sensitive environments
 For fixed and flexible applications (e.g. machinery building, wind turbines)
 Construction machinery
 Electric motor manufacturing

Product Management	Document: EPIC® ULTRA H-B 10 TS QB	1 / 3
--------------------	------------------------------------	-------

U.I. Lapp GmbH	DATASHEET	
	EPIC® ULTRA H-B 10 TS QB	70250211 14.11.2013

Product features

Housings with the BRUSH addition come with BRUSH cable screen contacting
 Pluggable with standard housings
 Corrosion-resistant according to DIN EN 6988
 Resistance to cyclic salt spray is tested according to IEC 68-2-52, severity level 2
 Salt spray testing according to DIN EN ISO 9227, method NSS, period of test 480 hours

Remark

Photographs are not to scale and do not represent detailed images of the respective products.

Technical Data

Article:	ULTRA H-B 10 TS QB 11-21
Cable clamping range (mm):	11 - 21
Pieces / PU:	1
Material:	Housing: nickel-plated zinc die-casting Lever and bolts: stainless steel Sealing: NBR Cable gland Body: nickel-plated brass Insert: PA Seal: special elastomer
Protection rating:	IP 68
Temperature range:	-40°C to +100°C

Product Management	Document: EPIC® ULTRA H-B 10 TS QB	2 / 3
--------------------	------------------------------------	-------

U.I. Lapp GmbH	<h1>DATASHEET</h1>	
	EPIC® ULTRA H-B 10 TS QB	70250211 14.11.2013

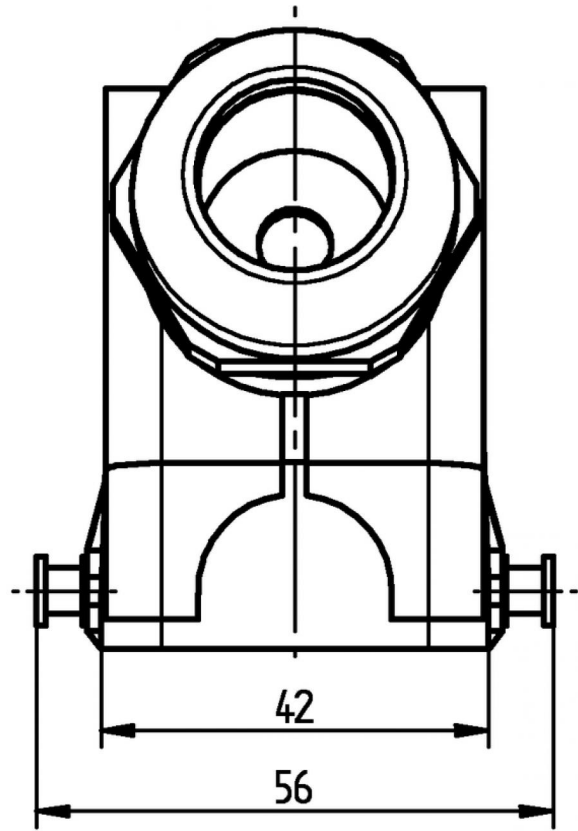
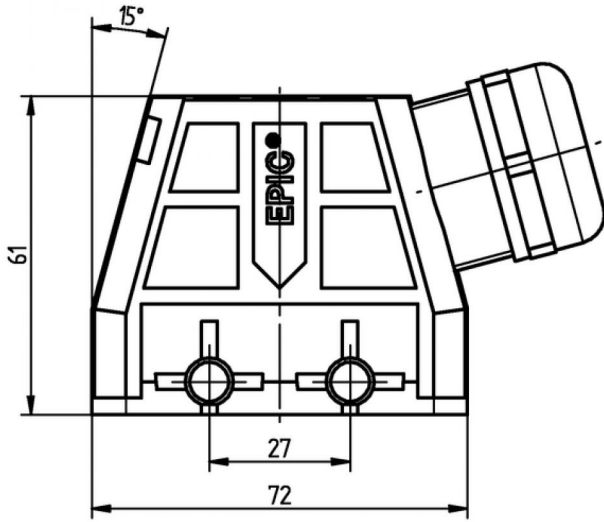

Product Management	Document: EPIC® ULTRA H-B 10 TS QB	3 / 3
--------------------	------------------------------------	-------