

U.I. Lapp GmbH	<h1>DATASHEET</h1>	
	EPIC® H-A 3 AGSV open bottom	19517200 14.11.2013

Innovative metal and plastic housing design
Housing in plastic or metal version. For power supply in the smallest possible space

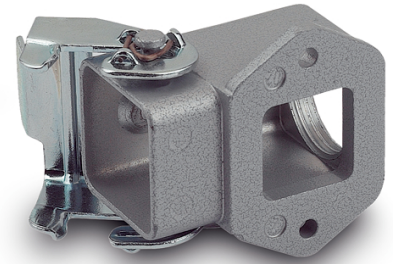

Industrial machinery and plant engineering



Mechanical resistance



Robust



Waterproof

Info

Compact, robust metal- and plastic housings size H-A 3

Application range

Machine and equipment manufacturing
Control engineering
Electronic laboratory

Product features

Surface-mount base
1 lever
2 cable entries
Housing type: with open base
Included: flat gasket

Remark

Photographs are not to scale and do not represent detailed images of the respective products.

Product Management	Document: EPIC® H-A 3 AGSV open bottom	1 / 3
--------------------	--	-------

U.I. Lapp GmbH	DATASHEET	
	EPIC® H-A 3 AGSV open bottom	19517200 14.11.2013

Technical Data

Article:	H-A 3 MAgsv M20
M:	20
Material:	Zinc die-casting
Colour:	grey
Pieces / PU:	10
Material:	Housing: powder-coated zinc die-casting, grey Lever: zinc-plated steel Sealing: NBR Housing: grey thermoplastic, black Lever: zinc-plated steel Sealing: NBR
Protection rating:	IP 65 (latched)
Temperature range:	-40 °C to +100 °C, short-term up to +125 °C
VDE-tested:	Certified production control: VDE-REG. no.: B437 UL-tested: UL File Number: E75770

Product Management	Document: EPIC® H-A 3 AGSV open bottom	2 / 3
--------------------	--	-------

U.I. Lapp GmbH	<h1>DATASHEET</h1>	 LAPP GROUP
	EPIC® H-A 3 AGSV open bottom	19517200 14.11.2013

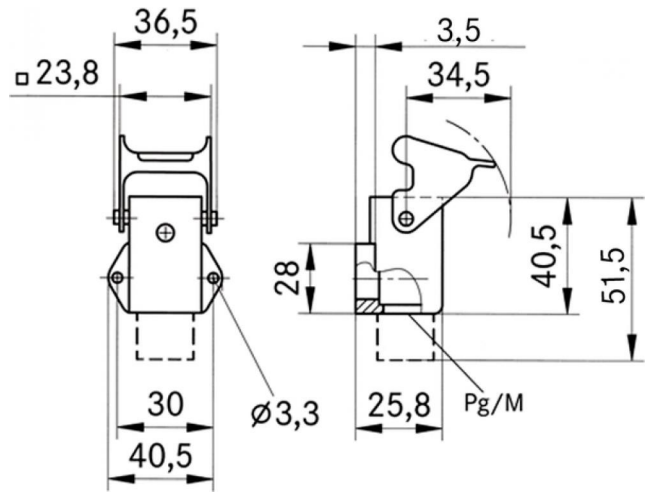
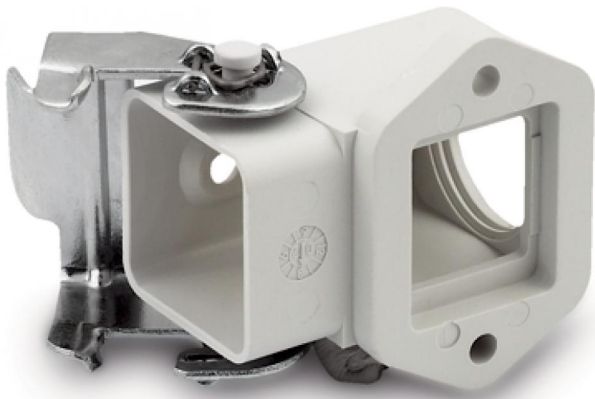

Product Management	Document: EPIC® H-A 3 AGSV open bottom	3 / 3
--------------------	--	-------