

U.I. Lapp GmbH	<b>DATASHEET</b>	
	<b>SKINDICHT® RWV</b>	52024010 14.11.2013

Strain relief  
Sealed by incised sealing ring  
Corrosion-resistant  
Decrease in installation height  
Seawater-resistant



Corrosion-resistant



Space requirement



Robust



### Application range

Angled glands are used in areas where cables have to run in parallel to the housing wall.  
Electric motor manufacturing  
Machine and equipment manufacturing  
Plant engineering  
Light and sound applications

### Design

PG connection thread

### Note

Counter nut to be used: SKINDICHT® SM  
For combination with other SKINDICHT® or SKINTOP® cable glands, we propose our SKINDICHT® RWV without incised sealing ring and compression screw

### Remark

Photographs are not to scale and do not represent detailed images of the respective products.

Product Management	Document: SKINDICHT® RWV	1 / 3
--------------------	--------------------------	-------

U.I. Lapp GmbH	<b>DATASHEET</b>	
	<b>SKINDICHT® RWV</b>	<b>52024010</b> <b>14.11.2013</b>

### Technical Data

Article designation / size:	RWV 21
A [mm]:	33.5
G mm:	30
Ø-B mm:	32.5
Overall length, C (mm):	34,8
Thread length, D (mm):	11.5
SW1/SW2 mm:	32 / 28
Pieces / PU:	10
Material:	Body: zinc die-casting Compression screw and hexagon nut: nickel-plated brass Incised sealing ring: CR O-ring: NBR
Protection rating:	IP 55
Temperature range:	-20°C to +80°C Without incised sealing ring: -20°C to +100°C

Product Management	Document: SKINDICHT® RWV	2 / 3
--------------------	--------------------------	-------

U.I. Lapp GmbH	<h1>DATASHEET</h1>	 <b>LAPP GROUP</b>
	<b>SKINDICHT® RWV</b>	<b>52024010</b> <b>14.11.2013</b>

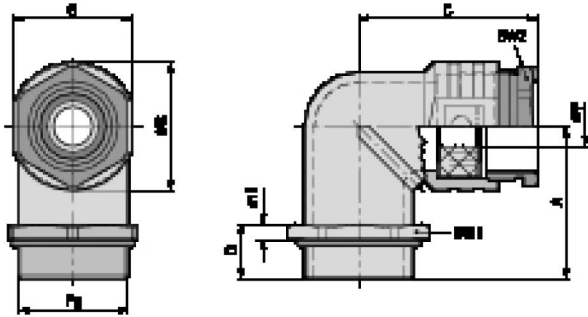

Product Management	Document: SKINDICHT® RWV	3 / 3
--------------------	--------------------------	-------