

- Limited Lifetime Warranty
- Medical Approvals
- Universal Input (85 - 265VAC)
- High Efficiency
- Broad 30W to 1500W product range
- RoHS Compliant Design

## HWS30-1500/ME Series

Single Output  
Medical Power Supplies

### Key Market Segments & Applications

Non-Surgical Medical Equipment  
Analysers

### HWS30-1500/ME Features and Benefits

#### Features

- Limited Lifetime Warranty
- Medical Approvals
- Wide Range AC Input

#### Benefits

- Lower Cost of Ownership
- Reduces System Approval Times
- Supports Global Use

### Specifications

ITEM	MODELS		HWS30	HWS100	HWS300	HWS600	HWS1000	HWS1500
			HWS50	HWS150				
Input Voltage range			85-265VAC (47-63Hz) or 120-370VDC		85-265VAC (47-63Hz) or 120-330VDC		85-265VAC (47-63Hz)	
Input Current (Typ)	(1)	A	0.8 / 0.4	1.3 / 0.65	4.1 / 2.1	8.1 / 3.9	13.5/7.0	19/10
Inrush Current	(1)	A	14 / 28		20 / 40			
Power Factor / Flicker			Meets EN61000-3-2, EN61000-3-3					
Temperature Coefficient	-		<0.02%/°C					
Overcurrent Protection	-		>104%					
Overvoltage Protection	V		Yes (See table on page 2)					
Hold Up Time (Typ)		ms	20					
Leakage Current (60Hz)	(2)	mA	<0.5mA					
Remote Sense			No			Yes		
Indicator	-		Green LED = ON					
Remote On/Off	-		No			Yes (Isolated from output)		
Parallel operation	-		No			Single wire conn. (5 units max)		
DC Good	-		No			Yes		
Voltage Programming			No					Yes
Operating Temperature and Derating	-		HWS30-150: -10°C to +70°C, (-10 to +50°C: 100%, +60°C: 60%, +70°C: 20%) HWS300-1500: -10°C to +70°C, (-10 to +50°C: 100%, derate linearly to 50% load from +50°C to +70°C)					
Storage Temperature	°C		-30°C to +85°C					
Humidity (non condensing)	-		Operating: 30 - 90%RH (10 -90% on HWS300-1500), Non operating 10 - 95%RH					
Cooling	-		Convection			Internal fan		
Withstand Voltage	(3)	-	Input to Ground 2kVAC, Input to Output 3kVAC, Output to Ground 500VAC for 1 min.					
Isolation Resistance	-		>100MΩ at 25°C & 70%RH, Output to Ground 500VDC, >10MΩ Output to remote on/off 100VDC					
Vibration (non operating)	-		10 - 55Hz (1 min sweep), 19.6m/s <sup>2</sup> constant, X, Y, Z axis, one hour each					
Shock (in packaging)	-		< 196.1m/s <sup>2</sup>					
Safety Agency Approvals	(2)	-	UL60601-1, EN60601-1, CSA-C22.2 No6011-M90 (C-UL) (basic insulation), CE Mark					
Line Dip	-		Complies with SEMI F47 (200VAC line only)					
Conducted & Radiated EMI	-		EN55011 / EN55022-B, FCC-B, VCCI-B (HWS600 & 1500 Class A)					
Immunity	-		IEC61000-4-2 (Level 2,3), -3, -4, -6, (Level 3), -5 (Level 3,4), -11					
Weight (Typ)	g		220 280	450 500	1000	1600	3200	3800
Size (WxHxD)	mm		26 x 82 x 95 26 x 82 x 120	28 x 82 x 160 37 x 82 x 160	61 x 82 x 165	100 x 82 x 165	126.5 x 82 x 240	280 x 82 x 126.5
Warranty			Limited Lifetime Warranty					

Notes: (1) 100/200VAC input (2) See clause 19.5DV.2 of UL60601 for equipment in proximity of patient (3) HWS300-600 2.5kVAC Input to ground

Model Selector									
Model	Voltage	Adjust Range	Max Curr(A) <sup>4</sup>	Max Power(W)	Load Reg(mV)	Line Reg(mV)	Ripple Noise(mV)	Overvoltage (V)	Efficiency (typ)% <sup>1</sup>
HWS30-5/ME	5V	4.0 - 6.0	6	30	40	20	120	6.25-7.25	77/80
HWS50-5/ME	5V	4.0 - 6.0	10	50	40	20	120	6.25-7.25	82/84
HWS100-5/ME	5V	4.0 - 6.0	20	100	40	20	120	6.25-7.25	83/86
HWS150-5/ME	5V	4.0 - 6.0	30	150	40	20	120	6.25-7.25	83/86
HWS600-5/ME	5V	4.0 - 6.0	120	600	30	20	120	6.25-7.25	80/83
HWS30-12/ME	12V	9.6 - 14.4	2.5	30	96	48	150	15-17.4	81/83
HWS50-12/ME	12V	9.6 - 14.4	4.3	51.6	96	48	150	15-17.4	81/83
HWS100-12/ME	12V	9.6 - 14.4	8.5	102	96	48	150	15-17.4	83/86
HWS150-12/ME	12V	9.6 - 14.4	13	156	96	48	150	15-17.4	83/86
HWS300-12/ME	12V	9.6 - 14.4	27	324	72	48	150	15-17.4	80/83
HWS600-12/ME	12V	9.6 - 14.4	53	636	72	48	150	15-17.4	80/83
HWS30-15/ME	15V	12.0 - 18.0	2	30	120	60	150	18.8-21.8	81/83
HWS50-15/ME	15V	12.0 - 18.0	3.5	52.5	120	60	150	18.8-21.8	81/83
HWS100-15/ME	15V	12.0 - 18.0	7	105	120	60	150	18.8-21.8	83/86
HWS150-15/ME	15V	12.0 - 18.0	10	150	120	60	150	18.8-21.8	83/86
HWS300-15/ME <sup>(5)</sup>	15V	12.0 - 18.0	22	330	90	60	150	18.8-21.8	82/85
HWS600-15/ME	15V	12.0 - 18.0	43	645	90	60	150	18.8-21.8	81/84
HWS30-24/ME	24V	19.2 - 28.8	1.3	31.2	192	96	200	30-34.8	83/86
HWS50-24/ME	24V	19.2 - 28.8	2.2	52.8	192	96	150	30-34.8	82/84
HWS100-24/ME	24V	19.2 - 28.8	4.5	108	192	96	150	30-34.8	84/87
HWS150-24/ME	24V	19.2 - 28.8	6.5	156	192	96	150	30-34.8	85/88
HWS300-24/ME	24V	19.2 - 28.8	14 (16.5 pk)	336	144	96	150	30-34.8	82/85
HWS600-24/ME	24V	19.2 - 28.8	27 (31 pk)	648	144	96	150	30-34.8	82/85
HWS1000-24/ME	24V	19.2 - 28.8	46 (58.5 pk)	1104	150	96	150	30-34.8	85/87
HWS1500-24/ME	24V	4.8 - 28.8 <sup>(7)</sup>	65/70 <sup>(1)</sup> (105pk <sup>(6)</sup> )	1560/1680 <sup>(1)</sup> (2520 pk <sup>(6)</sup> )	144	96	200	30-34.8	84/88
HWS1000-36/ME	36V	28.8 - 43.2	30.7 (39 pk)	1104	150	144	200	45-49.7	85/88
HWS1500-36/ME	36V	7.2 - 43.2 <sup>(7)</sup>	42/46.5 <sup>(1)</sup> (70 pk) <sup>(6)</sup>	1512/1674 <sup>(1)</sup> (2520 pk <sup>(6)</sup> )	150	144	200	34-49.7	84/88
HWS30-48/ME	48V	38.4 - 52.8	0.65	31.2	384	192	200	55.2-64.8	82/83
HWS50-48/ME	48V	38.4 - 52.8	1.1	52.8	384	192	200	55.2-64.8	83/85
HWS100-48/ME	48V	38.4 - 52.8	2.1	100.8	384	192	200	55.2-64.8	84/87
HWS150-48/ME	48V	38.4 - 52.8	3.3	158.4	384	192	200	55.2-64.8	85/88
HWS300-48/ME	48V	38.4 - 52.8	7	336	288	192	350	55.2-64.8	82/85
HWS600-48/ME	48V	38.4 - 52.8	13	624	288	192	350	55.2-64.8	83/86
HWS1000-48/ME	48V	38.4 - 52.8	23	1104	300	192	200	55.2-60	86/88
HWS1500-48/ME	48V	9.6 - 52.8 <sup>(7)</sup>	32	1536	288	192	200	55.2-64.8	86/90

(4) Peak load for 10s maximum on time, 35% duty cycle  
 (6) 200-265AC Input

(5) Safety Agency in progress - contact factory for status  
 (7) Using voltage programming input - see installation manual for details

Options	
Suffix	Description
Blank	No cover (except HWS300-1500 cover fitted) as standard
/A	Cover fitted (egHWS100-24/MEA) option available for HWS100 & HWS150 only

## Outline Drawing HWS100 Series

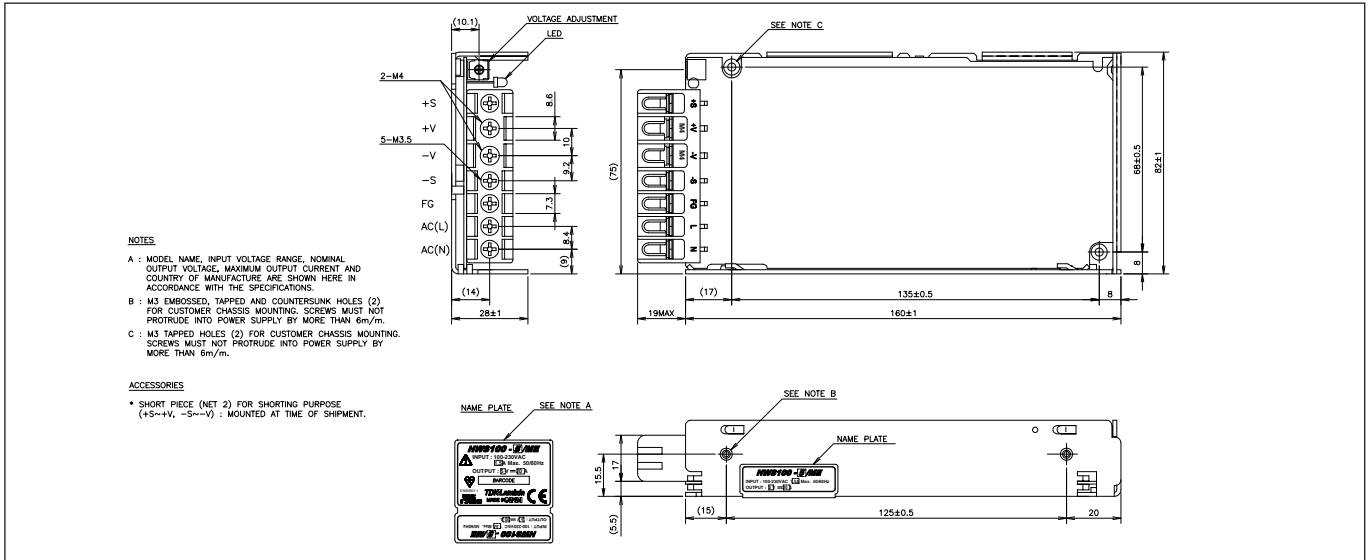

## Outline Drawing HWS300 Series

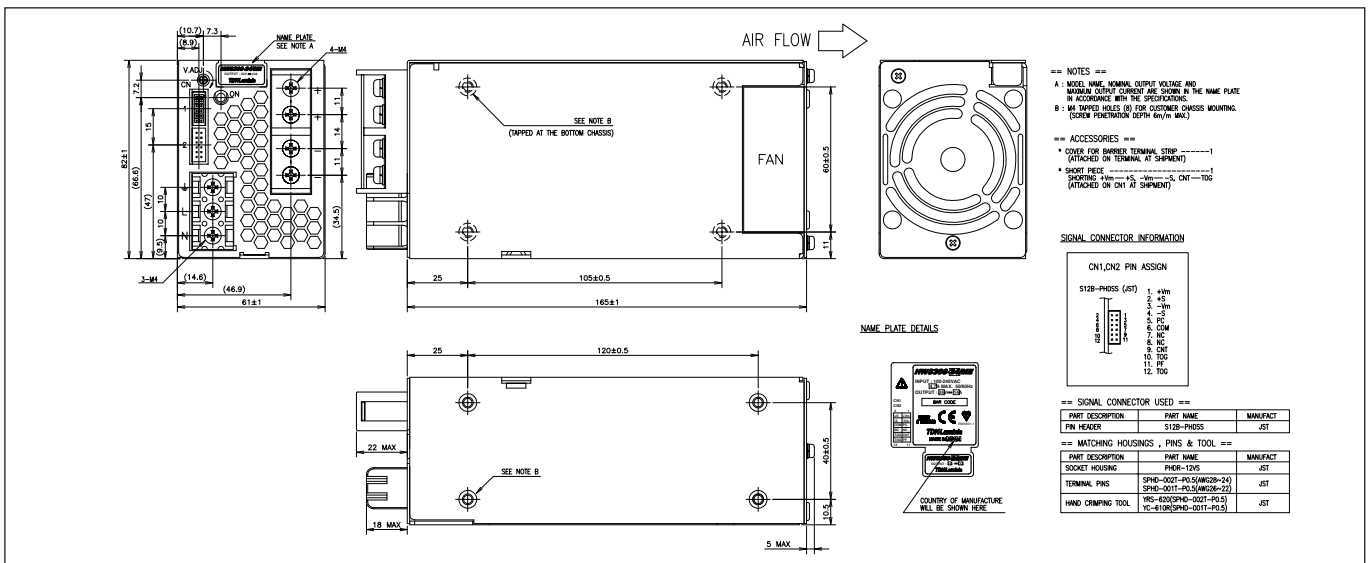

## Outline Drawing HWS1500 Series

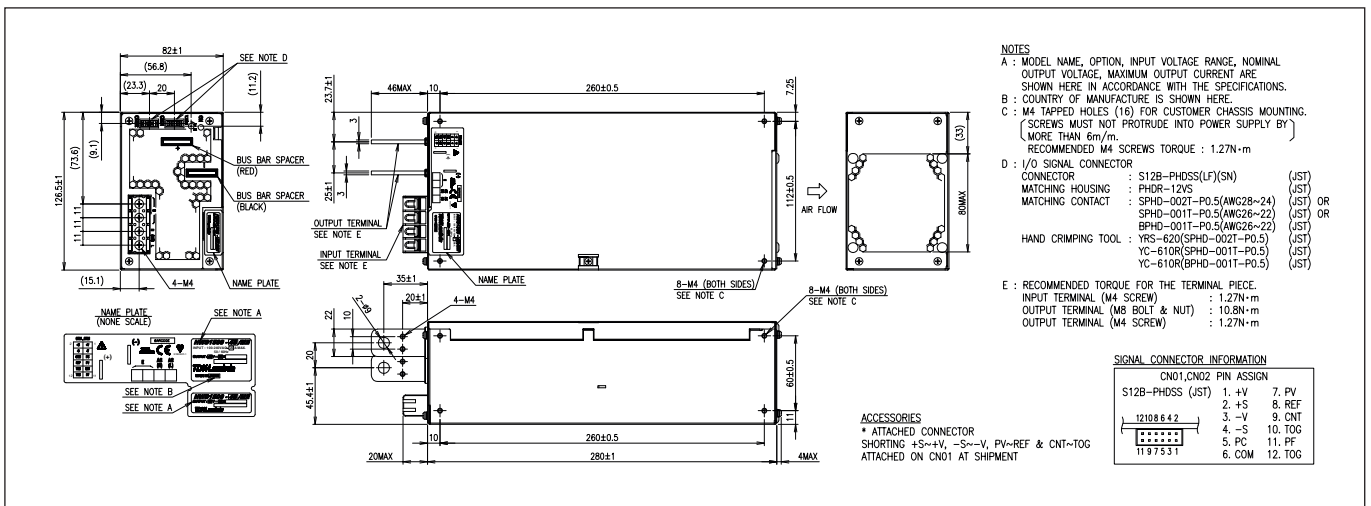



**TDK-Lambda France SAS**

ZAC des Delaches  
CS 41077  
9 rue Thuillere  
91978 Villebon Courtaboeuf  
France  
Tel: +33 1 60 12 71 65  
Fax: +33 1 60 12 71 66  
france@fr.tdk-lambda.com  
www.fr.tdk-lambda.com



**Italy Sales Office**

Via dei Lavoratori 128/130  
20092 Cinisello Balsamo (MI)  
Italy  
Tel: +39 02 61 29 38 63  
Fax: +39 02 61 29 09 00  
info.italia@it.tdk-lambda.com  
www.it.tdk-lambda.com



**Netherlands**

info@tdk-lambda.nl  
www.tdk-lambda.nl



**TDK-Lambda Germany GmbH**

Karl-Bold-Strasse 40  
77855 Achern  
Germany  
Tel: +49 7841 666 0  
Fax: +49 7841 5000  
info.germany@de.tdk-lambda.com  
www.de.tdk-lambda.com



**Austria Sales Office**

Aredstrasse 22  
2544 Leobersdorf  
Austria  
Tel: +43 2256 655 84  
Fax: +43 2256 645 12  
info.germany@de.tdk-lambda.com  
www.de.tdk-lambda.com



**Scandinavia Sales Office**

Valdemarsgade 7  
4100 Ringsted  
Denmark  
Tel: +45 24 63 95 65  
Fax: +45 69 80 44 99  
info@de.tdk-lambda.com  
www.emea.tdk-lambda.com



**Switzerland Sales Office**

Bahnhofstrasse 50  
8305 Dietlikon  
Switzerland  
Tel: +41 44 850 53 53  
Fax: +41 44 850 53 50  
info@de.tdk-lambda.com  
www.de.tdk-lambda.com



**TDK-Lambda UK Ltd.**

Kingsley Avenue  
Ilfracombe  
Devon EX34 8ES  
United Kingdom  
Tel: +44 (0) 12 71 85 66 66  
Fax: +44 (0) 12 71 86 48 94  
powersolutions@uk.tdk-lambda.com  
www.uk.tdk-lambda.com



**TDK-Lambda Ltd.**

Kibbutz  
Givat Hashlosha 48800  
Israel  
Tel: +9 723 902 4333  
Fax: +9 723 902 4777  
info@tdk-lambda.co.il  
www.tdk-lambda.co.il



**Russia**

**Technical Support:**  
St Petersburg  
Tel: +7 (812) 6580463  
**Sales:**  
Moscow  
info@tdk-lambda.ru  
www.tdk-lambda.ru

**Local Distribution**

