

Waldi-Leuchten GmbH - Am Güterbahnhof 2 - D-31303 Burgdorf - Tel. 0049 (0) 5136 - 809830

CE 2006/95/EC
2004/108/EC

09/12

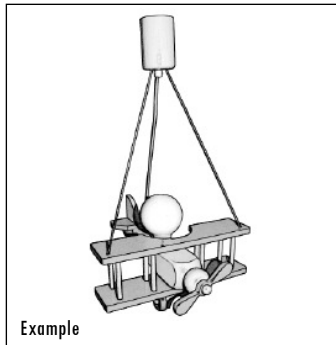

Contents:

- 1 lamp
- 1 safety instructions / fitting instructions

Dear Client,

Congratulations on buying a light produced by WALDI and you made a good choice! Nevertheless, for your own security we recommend to carefully read this manual.

Instruction for installation:

1. Before connecting the lamp, turn off the supply voltage.
2. Push down the canopy and hook it with the suspension device into the ceiling hook.
3. The supplied terminal is to be used for the mains supply.
4. An eventual existing protective wire at site has to be insulated in a proper way.
5. After having finished the mains connection, put the connecting terminal again on the suspension device.
6. Push the canopy over the ceiling hook up to and under the ceiling and fix it with the retainer on the lead.

Bulbs:

max. 60W/E27/230V or energy saving lamp 15W/E27/230V

General information

1. Only the bulbs specified may be used in the light.
2. For safety reasons, no other decorative parts may be attached to the light.
3. The light serves only for decoration purposes and is not suited as a child's toy.
4. Please keep these instructions in a safe place for later reference.
5. For cleaning the light we recommend to use a dry or slightly damp cloth. Pay attention not to penetrate with the cloth inside the socket.
Before cleaning switch off the light! When using a slightly damp cloth, you have to dry the light before switching it on again.

**The manufacturer shall not be liable for injuries or damage which are a result of the incorrect use or connection of the lamp.
In the case of doubt, please consult a qualified electrician.**