

ROYALOHM

C O N F I D E N T I A L D O C U M E N T

SPECIFICATION FOR APPROVAL

"Distributed by Conrad Electronic SE, Hirschau, Germany"

CONRAD

Description : Chip Kit Resistors

Royalohm Part no.:

0402WGFE024KIT (RMC KIT 1/16W (0402) +/- 1% & Jumper)
0603SAFE024KIT (RMC KIT 1/10W-S (0603) +/- 1% & Jumper)
0805S8FE024KIT (RMC KIT 1/8W-S (0805) +/- 1% & Jumper)
1206S4FE024KIT (RMC KIT 1/4W-S (1206) +/- 1% & Jumper)

Approved by

Parts corresponding to RoHS Compliant: 2005-Apr.-1

Royal Electronic Factory (Thailand) Co., Ltd.
20/1-2 Moo 2 Klong-Na, Muang
Chachoengsao 24000, Thailand
Tel: +66-38-822404-8
Fax: +66 38-981190 / 823765
E-mail Address: Export sales: Export@royalohm.com
Local sales: Local@royalohm.com
[http:// www.royalohm.com](http://www.royalohm.com)
P.O. Box 251 Klongchan, Bangkok 10240, Thailand

Approved	Checked	Prepared
Mr. Jack Lin	Mr. S. Polthanasan	Ms. P. Supatta

Issue Date: 2014/05/29

Customer: CONRAD

1. Scope:

This specification for approval relates to Thick Film Chip Resistors (Terminal Lead Free) manufactured by ROYALOHM 's specifications.

2. Type designation:

The type designation shall be in the following form:

Ex.

Type	Power Rating	Resistance tolerance	Nominal Resistance
RMC 0402	1/16W	F	75Ω
RMC 0603	1/10W-S		
RMC 0805	1/8W-S		
RMC 1206	1/4W-S		

3. Ratings:

Type	RMC 0402	RMC 0603	RMC 0805	RMC 1206
Power Rating	1/16W(0.0625W)	1/10W-S(0.10W)	1/8W-S(0.125W)	1/4W-S(0.25W)
Rated Current(Jumper)	1A	1A	2A	2A
Max. Overload Current(Jumper)	2A	2A	4A	4A
Max. Working Voltage	50 V	50 V	150 V	200 V
Max. Overload Voltage	100 V	100 V	300 V	400 V
Temperature Range	-55°C ~ +155°C			
Ambient Temperature	70 °C			

3.1 Power rating:

Resistors shall have a power rating based on continuous load operation at an ambient temperature of 70 °C . For temperature in excess of 70 °C , The load shall be derate as shown in figure 1.

Derating Curve

Figure 1

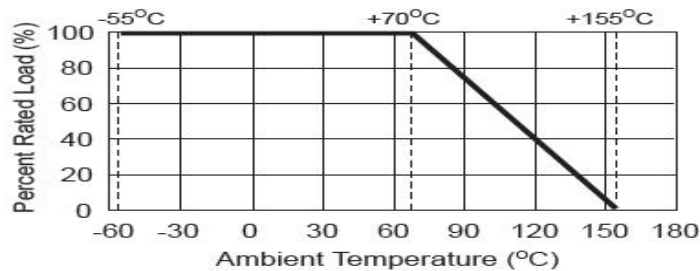

3.2 Nominal Resistance

Effective figures of nominal resistance shall be in accordance with E-24 and E-96 series for 1 % and E-24 series for 2 % and 5 %

4. Construction :

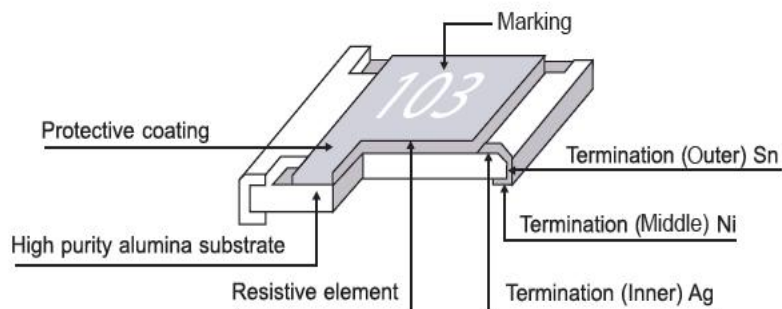

* Pd contained in termination (inner) 1.5% of homogeneous material.

Chip Kit Resistors

5. Power rating and dimensions:

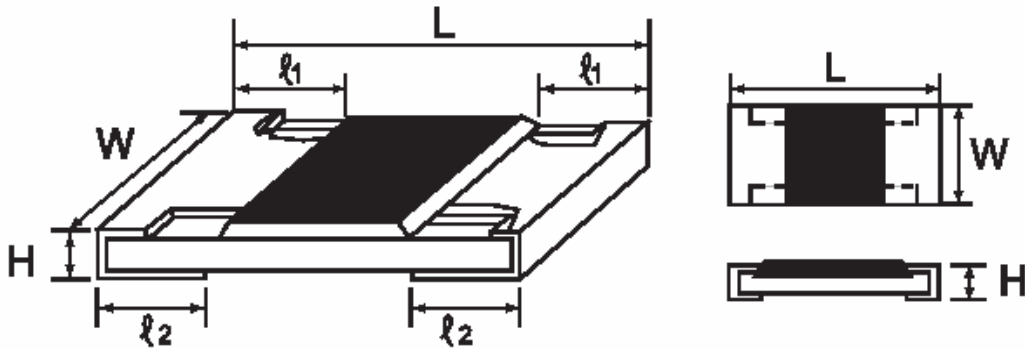

Dimension :

Type	Dimension (mm)				
	L	W	H	l1	l2
RMC 0402	1.00 ± 0.10	0.50 ± 0.05	0.35 ± 0.05	0.20 ± 0.10	0.25 ± 0.10
RMC 0603	1.60 ± 0.10	0.80 + 0.15 - 0.10	0.45 ± 0.10	0.30 ± 0.20	0.30 ± 0.20
RMC 0805	2.00 ± 0.15	1.25 + 0.15 - 0.10	0.55 ± 0.10	0.40 ± 0.20	0.40 ± 0.20
RMC 1206	3.10 ± 0.15	1.55 + 0.15 - 0.10	0.55 ± 0.10	0.45 ± 0.20	0.45 ± 0.20

Power Rating :

Type	Power Rating at 70 °C	Tolerance	Resistance Range	Standard Series
RMC 0402	1/16W	Jumper	< 50mΩ	E-24
		± 1	10Ω ~ 1MΩ	
RMC 0603	1/10W-S	Jumper	< 50mΩ	E-24
		± 1	10Ω ~ 1MΩ	
RMC 0805	1/8W-S	Jumper	< 50mΩ	E-24
		± 1	10Ω ~ 1MΩ	
RMC 1206	1/4W-S	Jumper	< 50mΩ	E-24
		± 1	10Ω ~ 1MΩ	

For E - 24 Series (see page 9 for value detail)

± 1%	E-24	1.0	1.1	1.2	1.3	1.5	1.6	1.8	2.0	2.2	2.4	2.7	3.0	3.3	3.6	3.9	4.3	4.7	5.1	5.6	6.2	6.8	7.5	8.2	9.1
------	------	-----	-----	-----	-----	-----	-----	-----	-----	-----	-----	-----	-----	-----	-----	-----	-----	-----	-----	-----	-----	-----	-----	-----	-----

Chip Kit Resistors

Mutiplier Code :

Code	A	B	C	D	E	F	G	H	X	Y	Z
Multiplier	0	1	2	3	4	5	6	7	-1	-2	-3
	10	10	10	10	10	10	10	10	10	10	10

Coding

Formula

Example : $10.2K\Omega = 102 \times 10\Omega = 02C$

XX

X

Resistance Code

Multiplier Code

$33.2\Omega = 332 \times 10^{-1}\Omega = 51X$

Value	Code	Value	Code	Value	Code	Value	Code	Value	Code
100	01	162	21	261	41	422	61	681	81
102	02	165	22	267	42	432	62	698	82
105	03	169	23	274	43	442	63	715	83
107	04	174	24	280	44	453	64	732	84
110	05	178	25	287	45	464	65	750	85
113	06	182	26	294	46	475	66	768	86
115	07	187	27	301	47	487	67	787	87
118	08	191	28	309	48	499	68	806	88
121	09	196	29	316	49	511	69	825	89
124	10	200	30	324	50	523	70	845	90
127	11	205	31	332	51	536	71	866	91
130	12	210	32	340	52	549	72	887	92
133	13	215	33	348	53	562	73	909	93
137	14	221	34	357	54	576	74	931	94
140	15	226	35	365	55	590	75	953	95
143	16	232	36	374	56	604	76	976	96
147	17	237	37	383	57	619	77		
150	18	243	38	392	58	634	78		
154	19	249	39	402	59	649	79		
158	20	255	40	412	60	665	80		

*Marking for 0603 E-96 series, the resistance value that no have multiplier code indicate marking follow this:
 The first two digits are significant figures of resistance and the third one denoted number of zeros and under line the marking letters.

Ex.

	<u>122</u>	
--	------------	--

1.2KΩ

Chip Kit Resistors

6. Marking :

6.1 Resistors

A. For E-96 series [$\pm 1\%$ (F) tolerance] in 0603 size 3 digit system (due to space restrictions) please refer to page 4 for coding formula

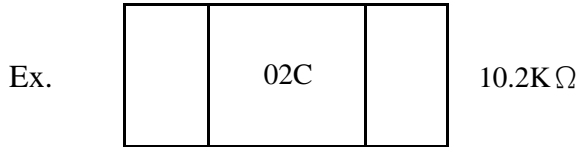

B. $\pm 1\%$ Tolerance 0805, 1206 : 4 Digits, the first three digits are significant figures of resistance and the fourth digit denoted number of zeros. Letter "R" is for decimal point.

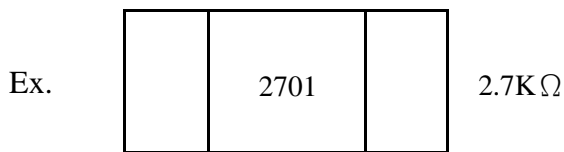

C. Chip Resistors type 0402 No marking

6.2 Labels

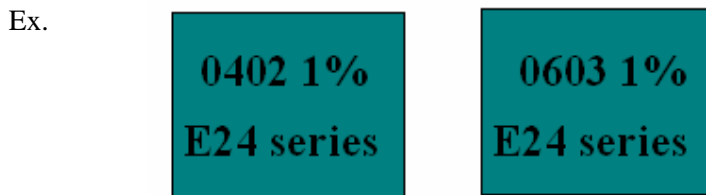

Chip Kit Resistors

7. Performance specification :

Characteristics	Limits	Test Methods (JIS C 5201-1)
*Insulation resistance	1,000 MΩ or more	Apply 500V DC between protective coating and termination for 1 min, then measure (Sub-clause 4.6)
*Dielectric withstanding voltage	No evidence of flashover mechanical damage, arcing or insulation break down	Apply 100V(0402) 300V(0603) & 500V (0805,1206,1210,2010,2512) AC between protective coating and termination for 1 minute (Sub-clause 4.7)
Temperature coefficient	1Ω~10Ω : ± 400 PPM/°C 11Ω~100Ω : ± 200 PPM/°C >100Ω : ± 100 PPM/°C	Natural resistance change per temp. degree centigrade. $\frac{R_2 - R_1}{R_1(t_2 - t_1)} \times 10^6 \text{ (PPM/°C)}$ R1: Resistance value at room temperature (t1) R2: Resistance value at room temp. plus 100 °C (t2) (Sub-clause 4.8)
Short time overload	Resistance change rate is ± (1.0% + 0.1 Ω) Max.	Permanent resistance change after the application of a potential of 2.5 times RCWW for 5 seconds (Sub-clause 4.13)
*Solderability	95 % coverage Min.	Test temperature of solder : 245 ± 3°C Dipping them solder : 2-3 seconds (Sub-clause 4.17)
Soldering temp. reference	Electrical characteristics shall be satisfied. Without distinct deformation in appearance. (95 % coverage Min.)	<p><u>Wave soldering condition:</u> (2 cycles Max.) Pre-heat : 100 ~ 120 °C, 30 ± 5 sec. Suggestion solder temp.: 235 ~ 255 °C, 10 sec. (Max.) Peak temp.: 260 °C</p> <p><u>Reflow soldering condition:</u> (2 cycles Max.) Pre-heat : 150 ~ 180 °C, 90 ~ 120 sec. Suggestion solder temp.: 235 ~ 255 °C, 20 ~ 40 sec. Peak temp.: 260 °C</p> <p>The graph shows a temperature profile starting at approximately 30°C. It rises to 150°C, then to 180°C. A horizontal line at 180°C is labeled 'Pre Heating Zone' with a duration of 90 ~ 120 sec. The temperature then rises to a peak of 260°C, labeled 'Peak: 260°C (Max)'. A range of 235°C ~ 255°C is also indicated. The peak is labeled 'Soldering Zone' with a duration of 20 ~ 40 sec. The x-axis is 'Heating time' and the y-axis is '(°C)'.</p> <p><u>Hand soldering condition:</u> The soldering iron tip temperature should be less than 300°C and maximum contract time should be 5 sec.</p>

Chip Kit Resistors				
7. Performance specification :				
Characteristics	Limits	Test Methods (JIS C 5201-1)		
Soldering Heat	Resistance change rate is: $\pm(1\%+0.05\Omega)$ Max.	Dip the resistor into a solder bath having a temperature of $260^{\circ}\text{C}\pm 3^{\circ}\text{C}$ and hold it for 10 ± 1 seconds. (Sub-clause 4.18)		
Temperature cycling	Resistance change rate is $\pm (0.5\% + 0.05 \Omega)$ Max.	Resistance change after continuous 5 cycles for duty cycle specified below :		
		Step	Temperature	Time
		1	$-55^{\circ}\text{C} \pm 3^{\circ}\text{C}$	30 mins
		2	Room temp.	10~15 mins
		3	$+155^{\circ}\text{C} \pm 2^{\circ}\text{C}$	30 mins
		4	Room temp.	10~15 mins
		(Sub-clause 4.19)		
Load life in humidity	Resistance change rate is $\pm (1.0\% + 0.1 \Omega)$ Max.	Resistance change after 1,000 hours (1.5 hours "on", 0.5 hour "off") at RCWV in a humidity chamber controlled at $40^{\circ}\text{C} \pm 2^{\circ}\text{C}$ and 90 to 95 % relative humidity (Sub-clause 4.24.2.1)		
Load Life	Resistance change rate is $\pm (1.0\% + 0.1 \Omega)$ Max.	Permanent resistance change after 1,000 hours operating at RCWV, with duty cycle of (1.5 hours"on", 0.5 hour"off") at $70^{\circ}\text{C} \pm 2^{\circ}\text{C}$ ambient (Sub-clause 4.25.1)		
Terminal bending	Resistance change rate is $\pm (1.0\% + 0.05 \Omega)$ Max.	Twist of Test Board : Y/X = 5/90 mm for 10 seconds (Sub-clause 4.33)		
The resistors of 0Ω only can do the characteristic noted of *				

Chip Kit Resistors

8. Kit resistors :

8.1 Insert for Chip Kit

Dimension (mm)

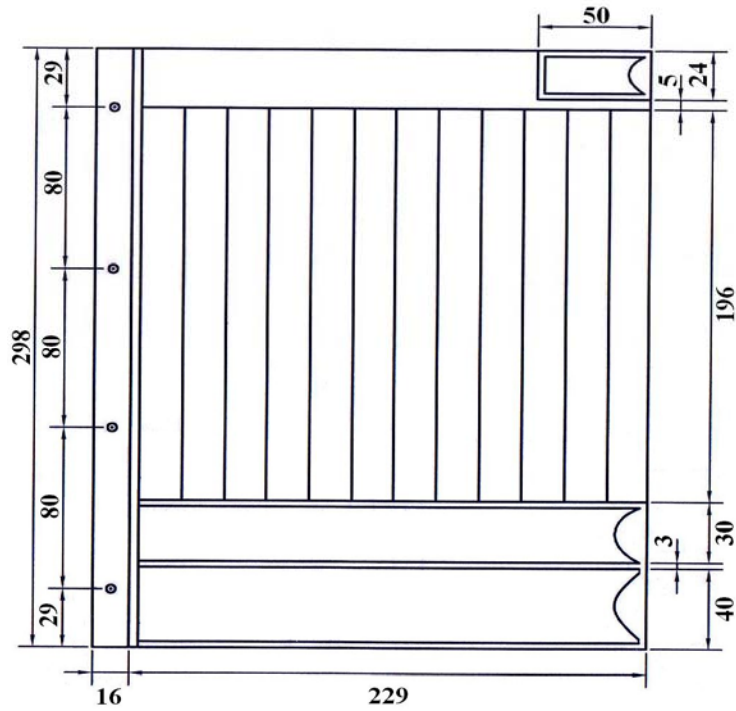

8.2 Album for Chip Kit

Dimension (mm)

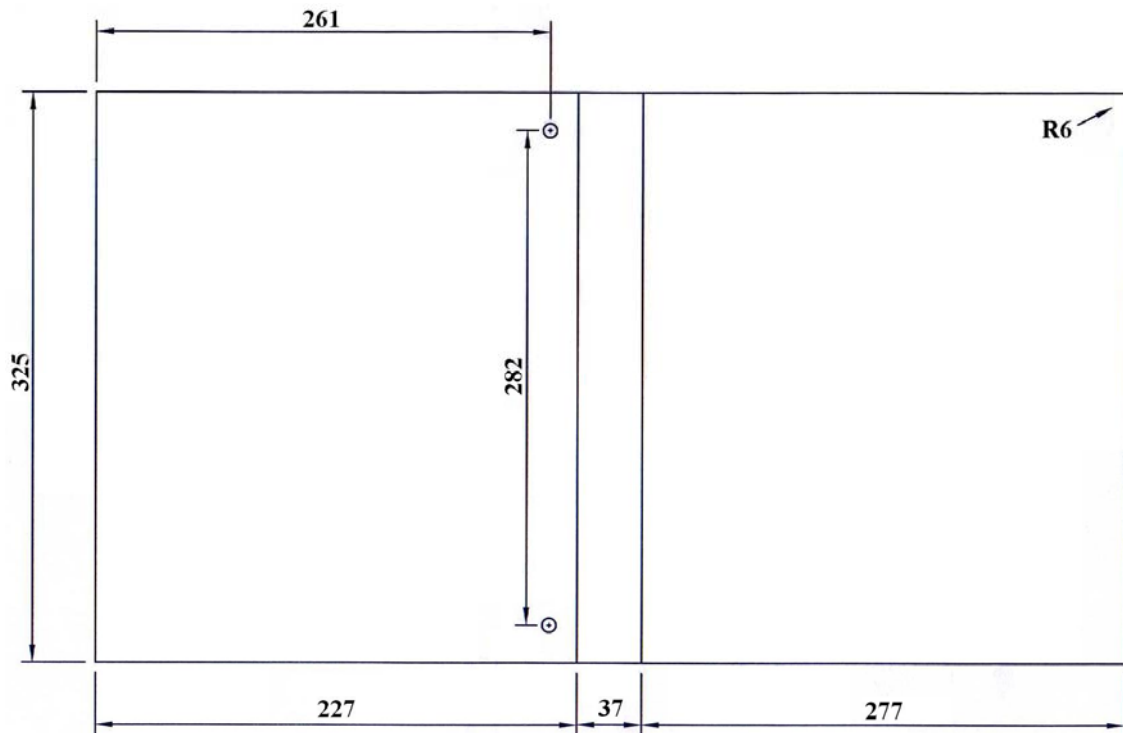

Part Number System

Explanation of Part Number System

Chip Kit Resistors

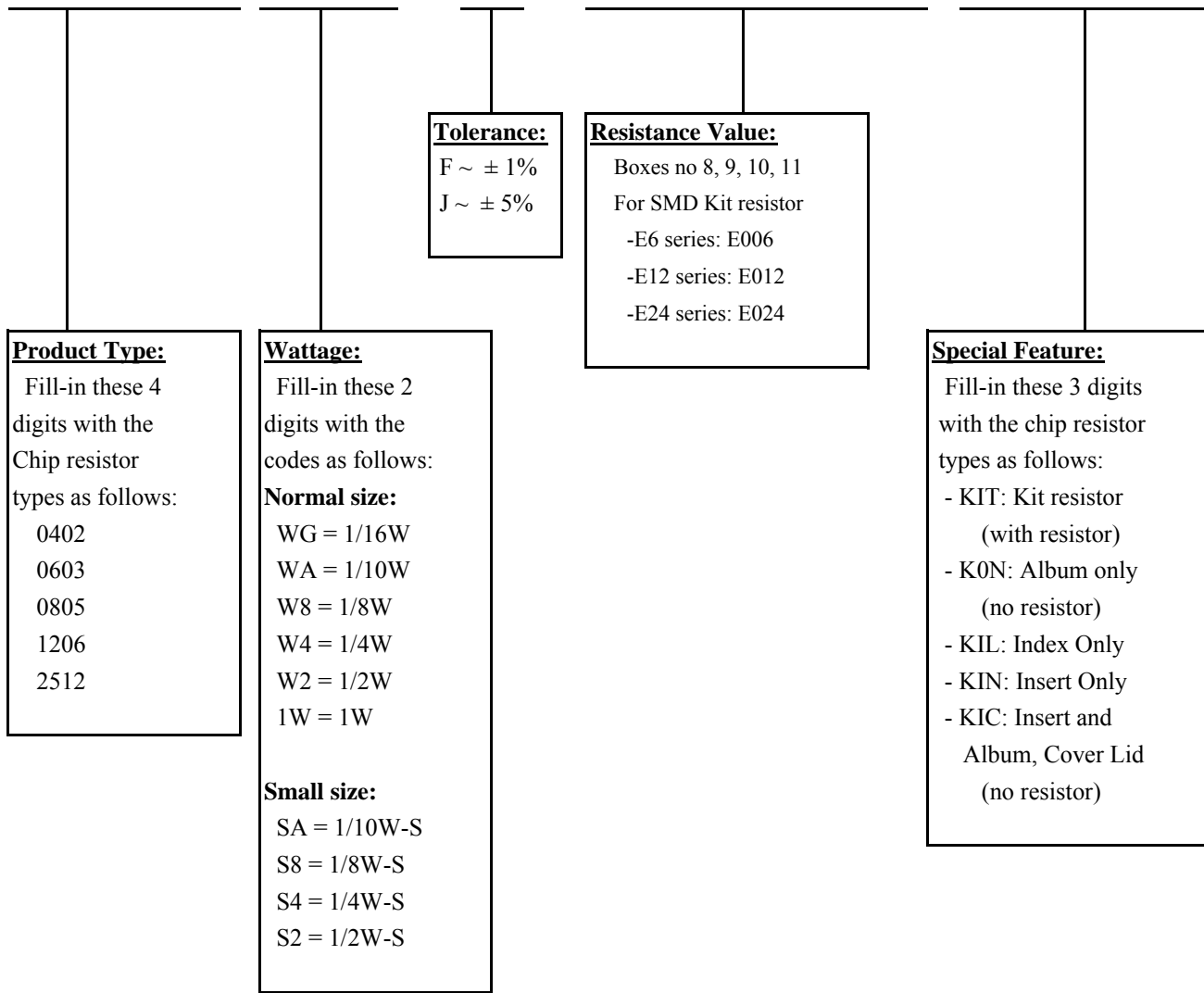
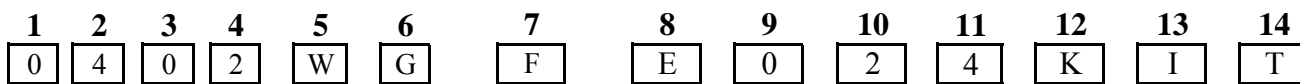

Product Type:
 Fill-in these 4 digits with the Chip resistor types as follows:
 0402
 0603
 0805
 1206
 2512

Wattage:
 Fill-in these 2 digits with the codes as follows:
Normal size:
 WG = 1/16W
 WA = 1/10W
 W8 = 1/8W
 W4 = 1/4W
 W2 = 1/2W
 1W = 1W

Small size:
 SA = 1/10W-S
 S8 = 1/8W-S
 S4 = 1/4W-S
 S2 = 1/2W-S

Tolerance:
 F ~ ± 1%
 J ~ ± 5%

Resistance Value:
 Boxes no 8, 9, 10, 11
 For SMD Kit resistor
 -E6 series: E006
 -E12 series: E012
 -E24 series: E024

Special Feature:
 Fill-in these 3 digits with the chip resistor types as follows:
 - KIT: Kit resistor (with resistor)
 - K0N: Album only (no resistor)
 - KIL: Index Only
 - KIN: Insert Only
 - KIC: Insert and Album, Cover Lid (no resistor)

Sample : Kit resistor 1/16W (0402) +/- 1% E-24 series (with resistor) → 0402WGFE024KIT
 Kit resistor 1/10W-S (0603) +/- 1% E-24 series (with resistor) → 0603SAFE024KIT
 Kit resistor 1/8W-S (0805) +/- 1% E-24 series (with resistor) → 0805S8FE024KIT
 Kit resistor 1/4W-S (1206) +/- 1% E-24 series (with resistor) → 1206S4FE024KIT

Chip Kit Resistors

Environment Related Substance

This product complies to EU RoHS directive, EU PAHs directive, EU PFOS directive and Halogen free.

Ozone layer depleting substances.

Ozone depleting substances are not used in our manufacturing process of this product.

This product is not manufactured using Chloro fluorocarbons (CFCs), Hydrochlorofluorocarbons (HCFCs), Hydrobromofluorocarbons (HBFCs) or other ozone depleting substances in any phase of the manufacturing process.

Storage Condition

The performance of these products, including the solderability, is guaranteed for a year from the date of arrival at your company, provided that they remain packed as they were when delivered and stored at a temperature of $25^{\circ}\text{C} \pm 5^{\circ}\text{C}$ and a relative humidity of $60\% \text{RH} \pm 10\% \text{RH}$

Even within the above guarantee periods, do not store these products in the following conditions. Otherwise, their electrical performance and/or solderability may be deteriorated, and the packaging materials (e.g. taping materials) may be deformed or deteriorated, resulting in mounting failures.

1. In salty air or in air with a high concentration of corrosive gas, such as Cl_2 , H_2S , NH_3 , SO_2 , or NO_2
2. In direct sunlight

Chip Kit Resistors

PRODUCT: RMC Kit (0402, 0603, 0805, 1206) +/-1%

E24 Series = 121 values (0R&10R to 1M)

(With resistor 100 pcs per value)

Total Qty: (0402, 0603, 0805, 1206) 12,100pcs.)

NO.	Value
1	0R
2	10R
3	11R
4	12R
5	15R
6	16R
7	18R
8	20R
9	22R
10	24R
11	27R
12	30R
13	33R
14	36R
15	39R
16	43R
17	47R
18	51R
19	56R
20	62R
21	68R
22	75R
23	82R
24	91R
25	100R
26	110R
27	120R
28	130R
29	150R
30	160R
31	180R
32	200R
33	220R
34	240R
35	270R

NO.	Value
36	300R
37	330R
38	360R
39	390R
40	430R
41	470R
42	510R
43	560R
44	620R
45	680R
46	750R
47	820R
48	910R
49	1K
50	1K1
51	1K2
52	1K3
53	1K5
54	1K6
55	1K8
56	2K
57	2K2
58	2K4
59	2K7
60	3K
61	3K3
62	3K6
63	3K9
64	4K3
65	4K7
66	5K1
67	5K6
68	6K2
69	6K8
70	7K5

NO.	Value
71	8K2
72	9K1
73	10K
74	11K
75	12K
76	13K
77	15K
78	16K
79	18K
80	20K
81	22K
82	24K
83	27K
84	30K
85	33K
86	36K
87	39K
88	43K
89	47K
90	51K
91	56K
92	62K
93	68K
94	75K
95	82K
96	91K
97	100K
98	110K
99	120K
100	130K
101	150K
102	160K
103	180K
104	200K
105	220K

NO.	Value
106	240K
107	270K
108	300K
109	330K
110	360K
111	390K
112	430K
113	470K
114	510K
115	560K
116	620K
117	680K
118	750K
119	820K
120	910K
121	1M