

STRAIN RELIEF AREA

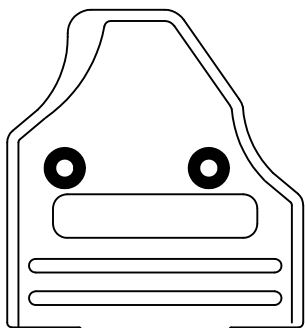

COVER HOOD

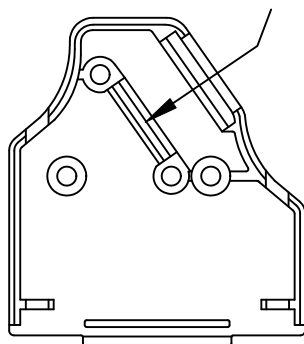

BASE HOOD

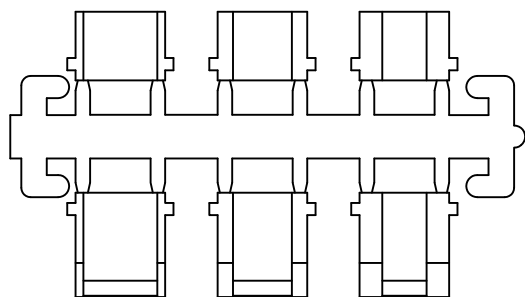

METALIZED PLASTIC INSERTS

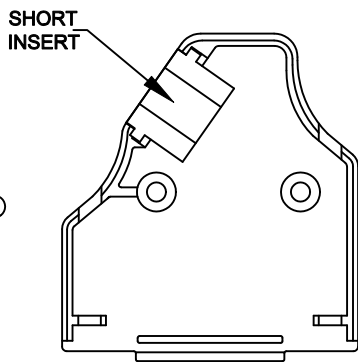

ITEM No. 3

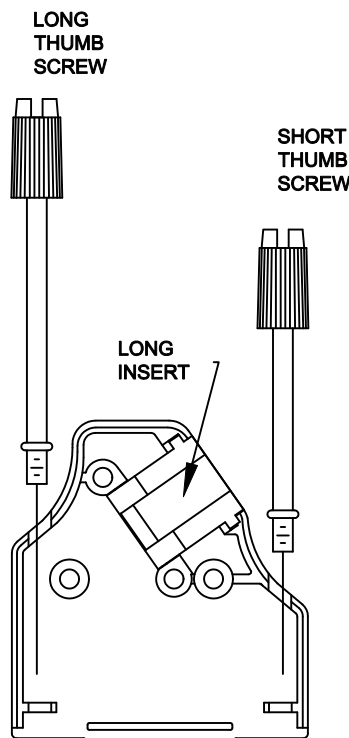

ITEM No. 2 & 6

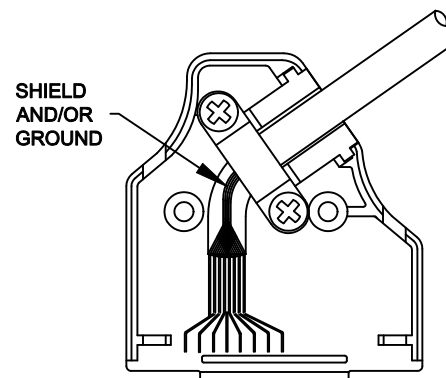

ITEM No. 4 & 5

ASSEMBLY INSTRUCTIONS:

1. PREPARE CABLE ENDS, CONNECT TO CONNECTOR
2. SELECT CORRECT INSERT SIZE FOR CABLE BEING USED, PLACE LONG INSERT INTO RECESS AREA OF BASE HOOD
3. PLACE SHORT INSERT INTO RECESS OF COVER HOOD
4. PLACE CABLE INTO INSERT IN BASE HOOD. USING EITHER THE FLAT OR CURVED STRAIN RELIEF (OR BOTH), CLAMP THE CABLE MAKING SURE THE JACKET IS BELOW THE STRAIN RELIEF
5. IF CABLE IS SHIELDED, FOLD SHIELD AND/OR GROUND WIRE BACK UNDER STRAIN RELIEF. CUT OFF ANY AXCESS WIRE SO IT DOES NOT STICK OUT OF THE STRAIN RELIEF
6. PLACE THE THUMBSCREWS INTO THE CORRECT POSITIONS OF THE BASE HOOD
7. PLACE THE CONNECTOR INTO THE BASE HOOD AND PLACE COVER HOOD ON TOP OF THE BASE HOOD, MAKING SURE NO WIRES ARE PINCHED
8. HOLDING THE HOODS TOGETHER, SCREW THE TWO HOOD SECTIONS TOGETHER USING THE SCREWS PROVIDED



CURVED STRAIN RELIEF



STRAIN RELIEF SCREW



FLAT STRAIN RELIEF



HOUSING SCREW

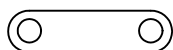
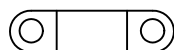

THESE DRAWINGS AND SPECIFICATIONS ARE THE PROPERTY OF MH CONNECTORS LTD. AND SHALL NOT BE REPRODUCED, COPIED OR USED AS THE BASIS FOR THE MANUFACTURE OR SALE OF APPARATUS WITHOUT WRITTEN PERMISSION.

DRAWN P. JENKINS	DATE 03-23-12
---------------------	------------------

APPROVED D. CROFT	DATE 03-23-12
----------------------	------------------

SCALE NTS	SHEET OF 1 OF 1	REV: A
--------------	--------------------	-----------

DRAWING No MHDM35 ASSEMBLY



MH CONNECTORS LTD.