

MA522-500M

RoHS
Compliant



□ □ : Poles
 500 : Pitch 5.00mm
 522 : Standard
 MA : Type

PCB Layout

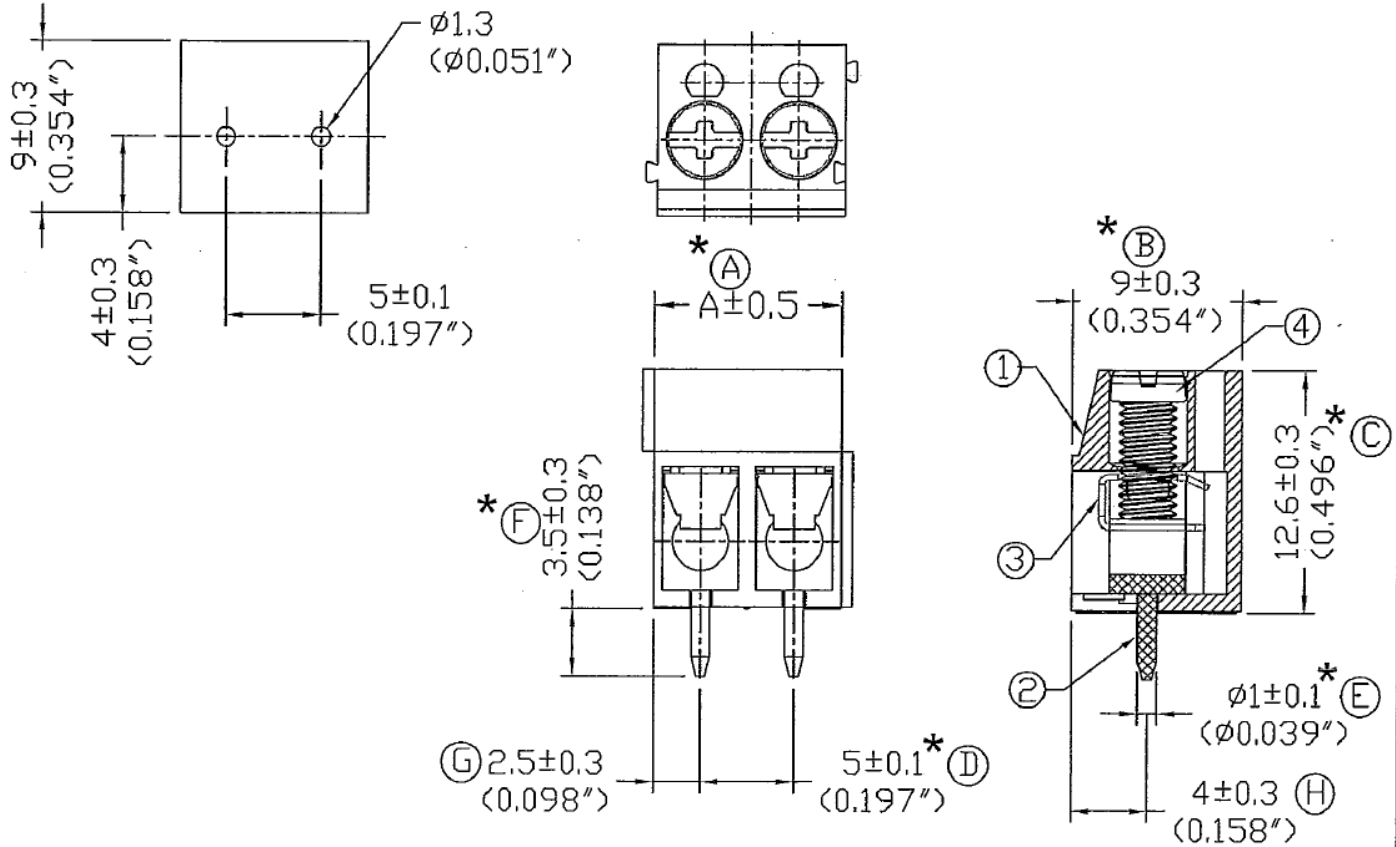

Pitch : 5.00mm(0.197inch)					
Poles	A(mm)	A(inch)	Poles	A(mm)	A(inch)
2	10.00	0.394	15	75.00	2.953
3	15.00	0.591	16	80.00	3.150
4	20.00	0.787	17	85.00	3.346
5	25.00	0.984	18	90.00	3.543
6	30.00	1.181	19	95.00	3.740
7	35.00	1.378	20	100.00	3.937
8	40.00	1.575	21	105.00	4.134
9	45.00	1.772	22	110.00	4.331
10	50.00	1.969	23	115.00	4.528
11	55.00	2.165	24	120.00	4.724
12	60.00	2.362	25	125.00	4.921
13	65.00	2.559			
14	70.00	2.756			

Current rating : 16Amp AC300V
 Insulation withstands volt : AC1500V min
 Insulation resistance : >2000MΩ DC500V
 Operation temperature : -40°C to +105°C
 Wire strip length : 4mm~5mm
 Wire range : 14~22 AWG
 Screw torque : 4.0 lb-inch

CONFIRMED & ACCEPTED BY

	Material	Plating/Finish	Remark
1	Insulating body Polyamide 66(UL94V-0)		Blue
2	Terminal Brass	Tin plated	
3	Wire protector Phosphor bronze	Tin plated	
4	Screw Steel	Zinc plated	

DECA

PART NO.	MA522-500M	VERSION	D	CONFIRMED BY	<i>W. H. H.</i>
SHEET OF	2/2	METRIC	MM	DRAWN BY	<i>Heiang-Ho</i>
				DATE	2011/01/28
				GENERAL MANAGER	<i>J. L. H.</i>