

# D-SUB HARDWARE ACCESSORIES

## Slide lock with holding bolt



RoHS compliant

### DESCRIPTION

- Slide lock set in two designs:
  - Type 3: 1 frame, 2 screws 4-40 UNC, 2 flat washers, 2 spring rings, 2 4-40 UNC nuts
  - Type 4: 1 frame, 2 4-40 UNC screws, 2 flat washers, 2 spring rings, 2 4-40 UNC nuts
- Holding bolt set consists of
  - 2 hex bolts, 2 flat washers, 2 spring rings, 2 nuts

### PRODUCT DRAWING

Type 3



No. of pos.	A	B	C
09	35.00	27.40	12.00
15	43.30	35.70	11.50
25	57.00	49.40	12.00
37	74.40	65.90	12.00
50	72.00	63.50	15.00

Type 4

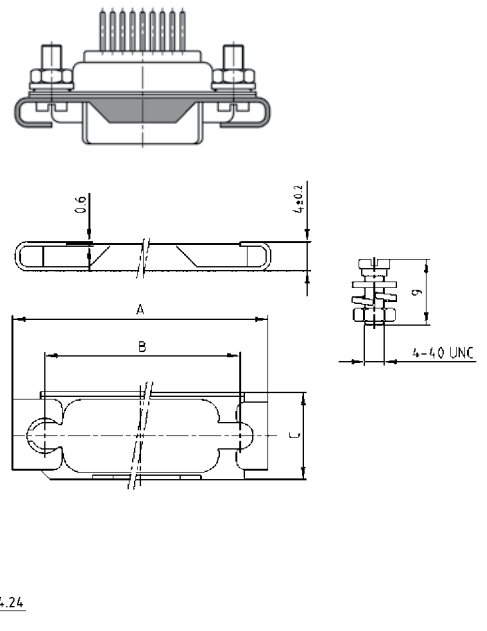

holding bolt for slide lock

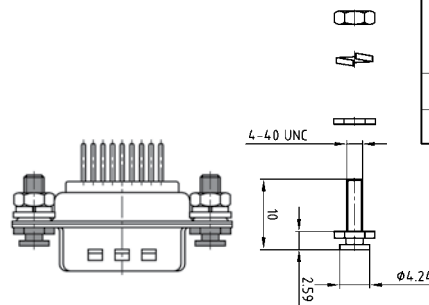

### ORDER DATA

#### SLIDE LOCK TYPE 3

No. of pos.	Design	Part Number
09	Slide lock set type 3	160X10159X
15	Slide lock set type 3	160X10169X
25	Slide lock set type 3	160X10179X
37	Slide lock set type 3	160X10189X
50	Slide lock set type 3	160X10199X

#### SLIDE LOCK TYPE 4

No. of pos.	Design	Part Number
09	Slide lock set type 4	160X10689X
15	Slide lock set type 4	160X10699X
25	Slide lock set type 4	160X10709X
37	Slide lock set type 4	160X10719X
50	Slide lock set type 4	160X10729X

#### HOLDING BOLT FOR SLIDE LOCK

No. of pos.	Design	Part Number
09 - 50	Slide lock type 3 and type 4	160X10209X