

**SPECIFICATION**  
**LITHIUM-ION RECHARGEABLE BATTERY**

**REFERENCE**

**Product Name: INR14500A80**

**Capacity: 800mAh**

APPLICATION ENGINEERING DIVISION

Revised on:		Prepared by:	Checked by:	Approved by:
2011-8-15				
Version:	A	Specification No.:	SPEC-A-INR14500A80	

## Contents

1. Preface	Page 3
2. Application Range	Page 3
3. Description	Page 3
4. Rated Specification	Page 3
5. Performance Curve	Page 4~5
6. Appearances	Page 6
7. Standard Environmental Test Conditions	Page 6
8. Test Instruments	Page 6
9. Product Liability	Page 7
10. Outline Dimensions	Page 7
11. Packaging State	Page 7
12. Warranty	Page 7
13. Others	Page 7
14. Prohibitions and Cautions in Handling	Page 8~9
15. Product Drawing	Page 10

# Lithium-ion Rechargeable Battery

## 1. Preface

This Product Specification describes the technique requirements, test procedures and precaution notes of Lithium-ion Rechargeable Battery to be supplied to Tensai International

## 2. Application Range

This specification is applied to Lithium ion Battery INR14500A80 delivered to Tensai International

## 3. Description

3.1 Description Lithium ion rechargeable battery

3.2 Battery Model INR14500A80

Note: INR\*14\*500\*A\*80= LiNMC Cylindrical \*Diameter\* Height \*Cap Kind\*Capacity

## 4. Rated Specification

4.1	Typical Capacity	800mAh	Standard Discharging after Standard Charging
4.2	Minimum Capacity	760mAh	
4.3	Nominal Voltage	3.6V	
4.4	Internal Impedance	≤ 85mΩ	
4.5	Energy	2.88Wh	
4.6	Charging Method	Constant Current with limited Voltage	
4.7	Standard Charging	4.20V,160mA,24mA cut-off,25℃	
4.8	Quick Charging	4.20V,560mA,8mA cut-off,25℃	
4.9	Charging Voltage	Max.4.25V	
4.10	Standard Discharging	160mA(0.2C)(constant current,3.0V cut-off, 25℃)	
	Continuous Discharging	800mA(1C)(45℃ or under)	
4.11	Max. Pulse Discharge Current	<5sec 2400mA (3C)	
4.12	Discharge Cut-off Voltage	3.0V	
4.13	Battery Weight	26g or less	
4.14	Battery Dimension	Height with tube	48.8 ±0.2mm
		Diameter with tube	14 +0.2/-0.1mm
4.15	Operating Ambient Temperature and Humidity Range	within 0 to 60℃, 45 to 85%RH (in standard charging)	
		within 10 to 45℃, 45 to 85%RH (in quick charging)	
		within -20 to 60℃, 45 to 85%RH (in standard discharging)	
4.16	Storage Ambient Temperature and Humidity Range	within -20 to 35℃, 45 to 85%RH (within 1 year)	
		within -20 to 40℃, 45 to 85%RH (within 6 months)	
		within -20 to 45℃, 45 to 85%RH (within 1 month)	
		within -20 to 50℃, 45 to 85%RH (within 1 week)	
4.17	Shelf Life	1 year	Typical value from ship state

# Lithium-ion Rechargeable Battery

## 5. Performance Curve

### 5.1 Charging Characteristics

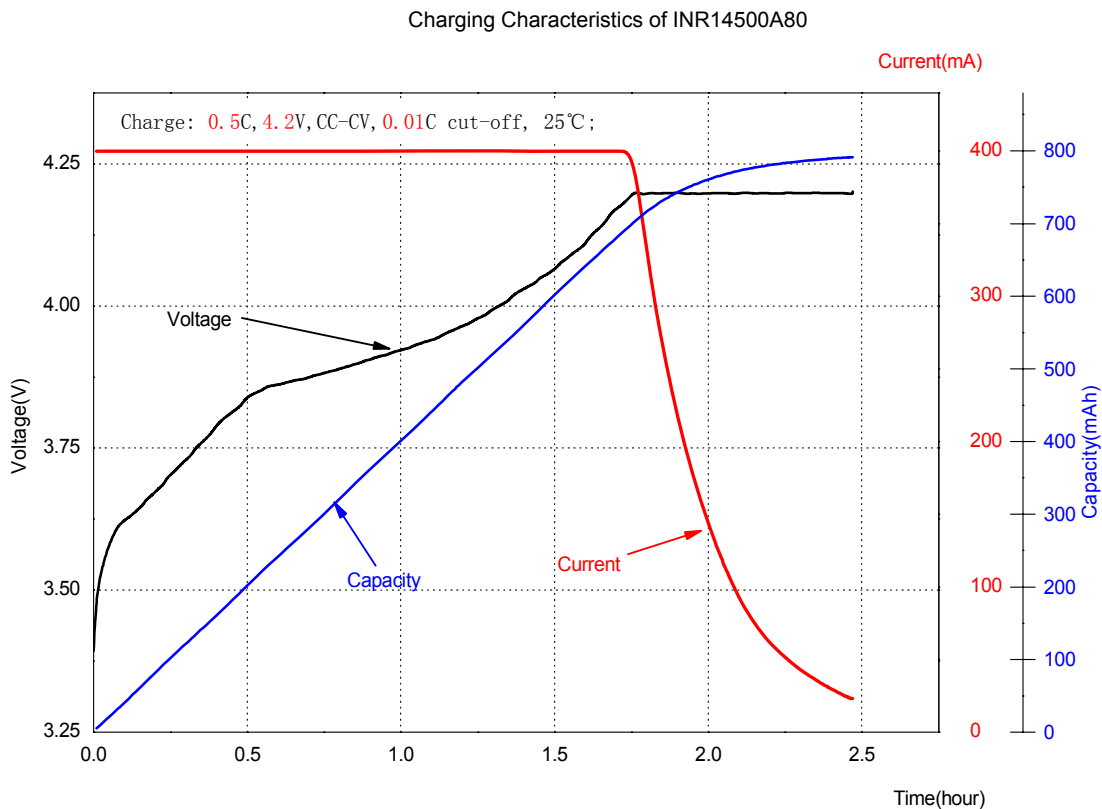

### 5.2 Different Rate Discharge Characteristics

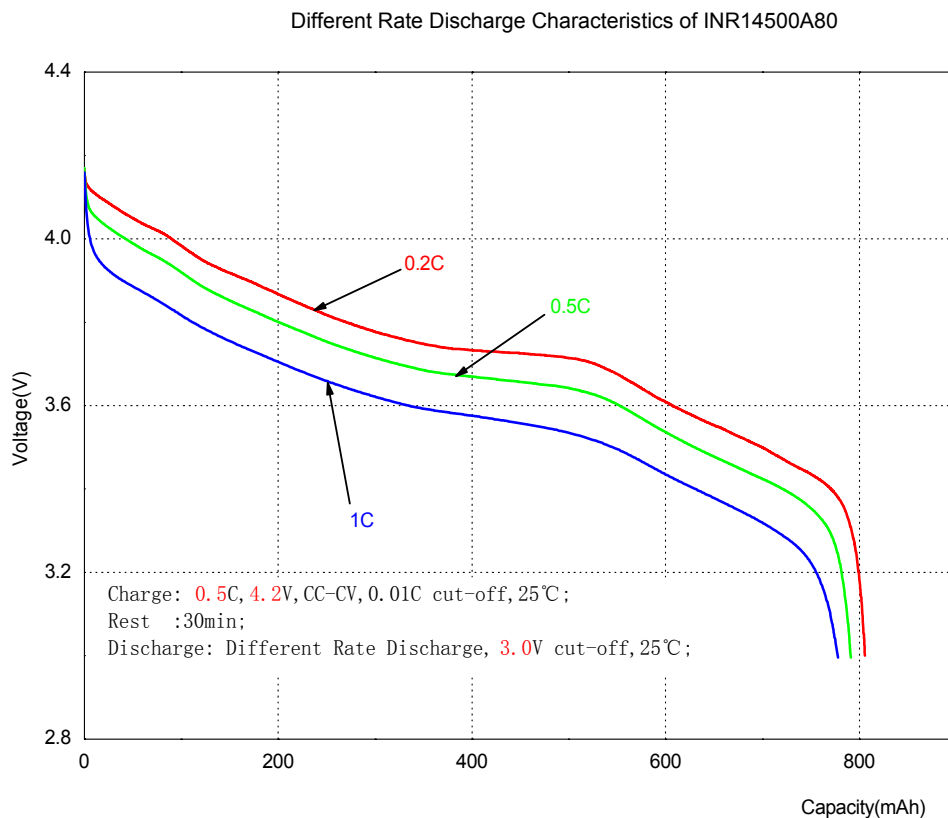

# Lithium-ion Rechargeable Battery

## 5.3 Storage Characteristics

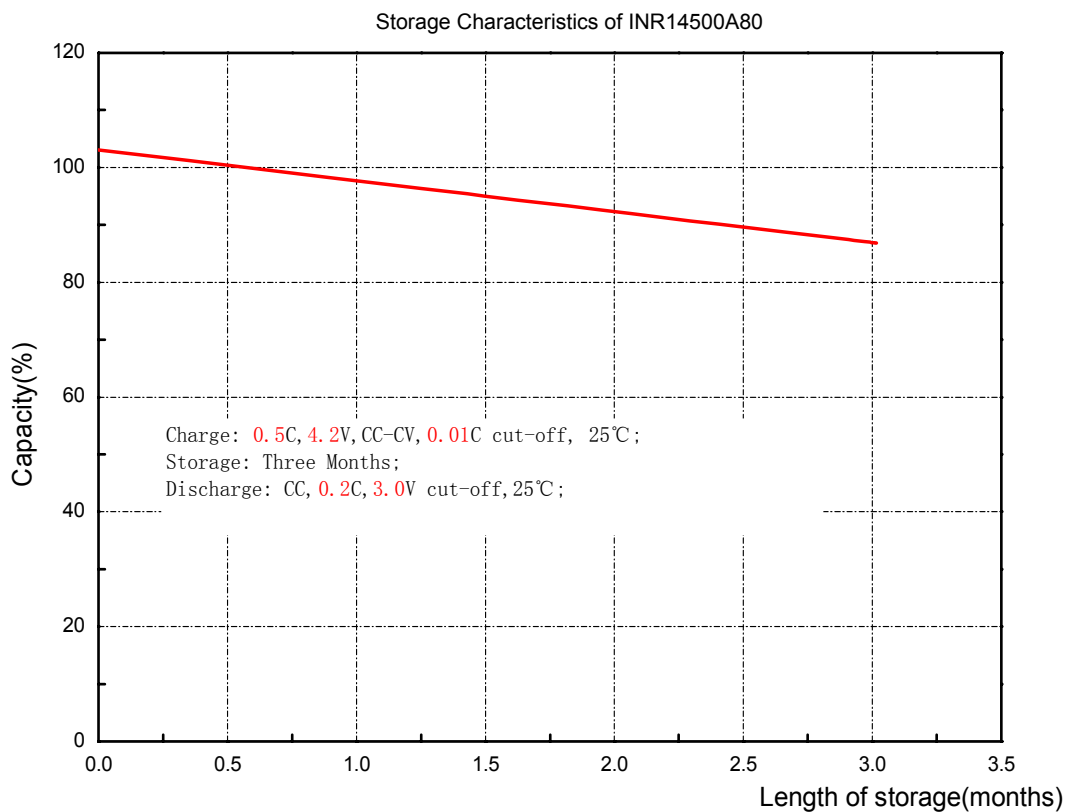

## 5.4 Cycle Life Characteristics

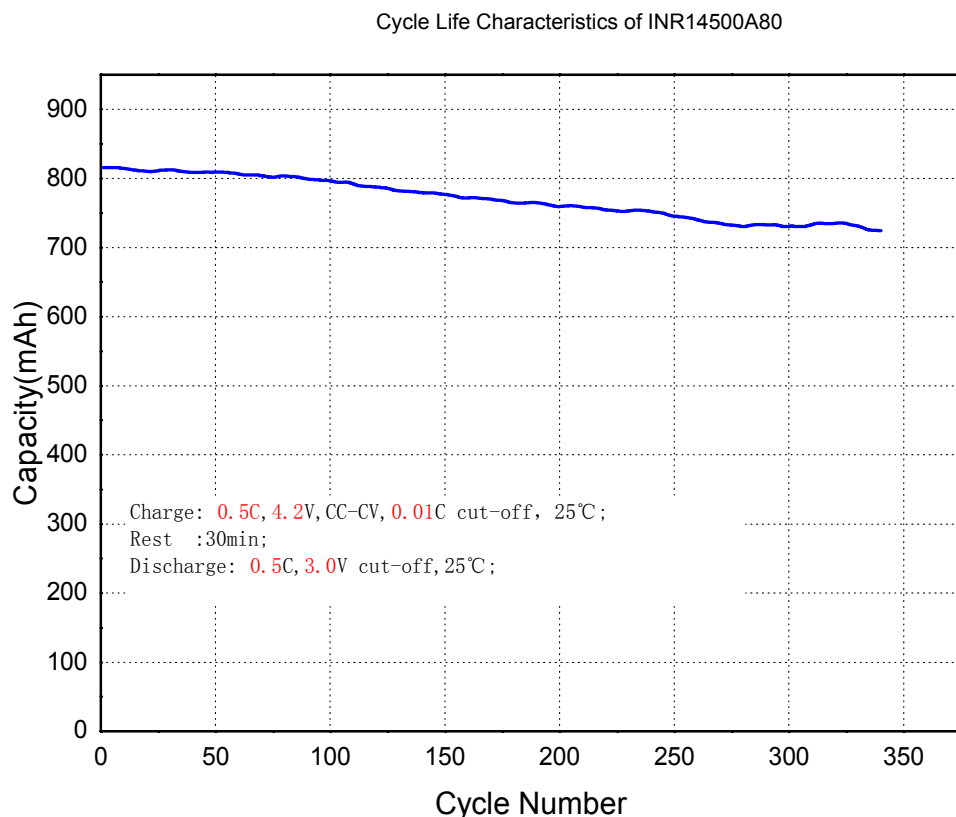

# Lithium-ion Rechargeable Battery

## 6. Appearances

There shall be no such defect as scratch, flaw, crack, rust, discoloration, leakage, which may adversely affect commercial value of the Battery.

## 7. Standard Environmental Test Conditions

Unless otherwise specified, all tests stated in this Product Specification are conducted at temperature  $20\pm 5\text{ }^{\circ}\text{C}$  and humidity  $65\pm 20\%$ RH. If it is judged that the test results are not affected by such conditions, the tests may be conducted at temperature  $15\sim 30\text{ }^{\circ}\text{C}$  and humidity  $25\sim 85\%$ RH.

## 8. Test Instruments

Items		Test methods	Judgment criteria
8.1	Indication Appearance	Visual check.	There are not excessive dirt, deformation and flaws.
8.2	Dimensions	Measured by calipers.	The data is in allowance of dimensions in Page 10 appended drawing.
8.3	Weight	Measured by balance.	26g or less
8.4	Open Circuit Voltage	Measure open circuit voltage within 1 hour after standard charging.	$4.2\pm 0.05\text{V}$
8.5	Internal Resistance	Measure internal resistance within 1 hour after standard charging.	$\leq 85\text{m}\Omega$
8.6	Rated Capacity	Measure capacity by standard discharging within 1 hour after standard charging.	$\geq 760\text{mAh}$
8.7	High Rate Discharging	Measure capacity by discharging (in the below condition) within 1 hour after standard charging. ●Discharging: 800mA (1C) down to 3.0V	$\geq 720\text{mAh}$
8.8	High Temperature Discharging	Measure capacity by holding at $45\pm 2\text{ }^{\circ}\text{C}$ for 4 hours after standard charging and discharging in the below condition. ●Discharging: 160mA (0.2C)A down to 3.0V	$\geq 720\text{mAh}$
8.9	Low Temperature Discharging	Measure capacity by holding at $0\pm 2\text{ }^{\circ}\text{C}$ for 4 hours after standard charging and discharging in the below condition. ●Discharging: 160mA (0.2C) down to 3.0V	$\geq 640\text{mAh}$
8.10	Cycle Life	300 cycle charging/discharging is repeated in the below condition. ●Charging: 4.2V,400mA ,8mA cut off, CC-CV ; ●Rest time: 30 min. between charging and discharging. ●Discharging: 400mA down to 3.0V. ●Temperature: $25\pm 2\text{ }^{\circ}\text{C}$ Measure capacity on the 301st cycle after repeating of 1 cycle standard charging/standard discharging.	$\geq 560\text{mAh}$
8.11	Storage	The capacity is measured by standard discharging after the below condition. Charged battery should be stored for 14 days at $60\text{ }^{\circ}\text{C}$ then perform standard discharging and standard charging cycles for 2 cycles.	$\geq 640\text{mAh}$
		The capacity is measured by standard discharging after the below condition. Discharged battery should be stored for 14 days at $60\text{ }^{\circ}\text{C}$ then perform standard charging cycles for 2 cycle.	$\geq 680\text{mAh}$
8.12	Leakage	Leave in the atmosphere at temperature $33\pm 3\text{ }^{\circ}\text{C}$ , humidity $85\pm 5\%$ RH for 2 weeks after standard charging.	No leakage.
8.13	Vibration	Vibrate the Battery in triaxial direction for 90 min , per axis in condition of frequency 10-55Hz (1Hz per min.) and amplitude 1.6mm p-p.	No fire. No explosion.
8.14	Shock Drop	Drop the Battery onto concrete board from 75cm height 3 times.	No fire. No explosion.

## Lithium-ion Rechargeable Battery

Items		Test methods	Judgment criteria
8.15	Short Circuit	Short circuit the lead wire (resistance 30mΩ or under) across" + "and" - "terminals of the Battery after standard charging.	No fire. No explosion.
8.16	Overcharge Test	Charge by constant Current of 2C and constant voltage of 5V for 2 hours.	No explosion, and no fire
8.17	Overdischarge Test	After standard charge .Discharged by constant Current of 0.2C to 3.0V,and the positive and negative terminal is connected with a 30Ω wire for 24 hours.	No explosion, and no fire

### 9. Product Liability

The Safety should be sure to confer previously with between the both parties.

The results of the conference must be recorded and the range of the liability or the burden should be cleared.

The indications of a warning are established by conference with between the both parties.

### 10. Outline Dimensions

Product drawing - Refer to appended Drawing. (Page 10)

### 11. Packaging State

Packing state - Charging capacity of delivered Battery is about 60%

### 12. Warranty

As long as the Battery is treated in accordance with this Product Specification and / or Handling Precautions and Prohibitions, Supplier warrants that the Battery should be free from any defect for a period of 1 year (20 °C or less) from the date of shipment or for 300 cycles (see 8.10), whichever comes earlier.

The warranty set forth above or described in Handling Precautions and Prohibitions for Lithium Ion Rechargeable Batteries excludes a defect, which is not related to manufacturing of the Battery.

### 13. Others

13.1 Storage for a long time if Battery or pack is preserved for a long time (3 or 4 months), the Battery or pack is preserved at the 40+/-20%RH and 23+/-2 °C temperature.

13.2 Any other matters that the specification does not cover should be conferred between the both parties.

# Lithium-ion Rechargeable Battery

## Prohibitions and Cautions in Handling the Lithium-ion Battery Pack

### 1. Scope

This document defines the Prohibitions and Cautions in Handling the Lithium-ion Battery INR14500A80. The Battery which YLE supplies to Tensai is used for the battery pack. When the Battery is used under the different conditions from those stated in this document, different restrictions and conditions shall be applied. (YLE needs new tests in may be) Please consult YLE again. YLE is not responsible for the troubles caused by mishandling of the Battery which is clearly against the instructions in this document. When YLE finds the new fact which requires modification in the contents of this document, we will inform you again.

### 2. General Prohibitions and Cautions in Handling the Lithium-ion Battery

- 1) Mishandling of the Battery may cause heat, explosion and fire. Be sure to observe the following.
  - Do not throw the Battery into fire or heat it.
  - Do not use the Battery with + and - in reversed.
  - Do not connect + and - terminals with wire or other metal (Do not short-circuit the Battery.).
  - Do not pierce the Battery with a nail, strike it with a hammer, step on it or otherwise subject it to strong impact.
  - Do not directly solder to the Battery.
  - Do not allow the Battery to be immersed in or wetted with water or sea-water.
  - Do not put the Battery into the microwave oven or high pressure container.
- 2) Never disassemble or modify the Battery. The safety mechanisms are incorporated in the Battery to prevent danger. Damaged safety mechanism may cause heat, explosion and fire.
- 3) Do not leave the Battery in places of the high temperature like the side of a fire or stove or under strong direct sunlight. This may cause heat, explosion and fire. In addition, performances and service life of the Battery may be deteriorated.
- 4) Immediately stop using the Battery, if you notice heat, discoloration, deformation, damage on external tube, or anything wrong, during use or storage of the Battery. Move the Battery away from a fire immediately when you notice a foul odor due to leakage.
- 5) When electrolyte of the Battery splashes into the eyes, immediately flush the eyes thoroughly with clean water without rubbing and take a medical treatment immediately. If appropriate procedures are not taken, this may cause a loss of sight.

### 3. Prohibitions and Cautions in Charging the Lithium-ion Battery

- 1) When the Battery is charged, the specified charge method and current described in this document should be applied. If charge current exceeds the upper limit of the specified range, characteristics and safety of the Battery could be deteriorated, or it may cause heat, explosion and fire.
- 2) Charge voltage should be less than 4.2V. Even if you consider the voltage control accuracy, the maximum voltage of the battery should be 4.25V. If the charge voltage exceeds the upper limit of the specified range, characteristics of the battery could be remarkably deteriorated.
- 3) The battery shall be charged within the range of Operating Ambient Temperature in the Product Specification and the battery temperature may not exceed 60 °C during charging.

### 4. Prohibitions and Cautions in Discharging the Lithium-ion Battery

- 1) The discharge current should not exceed the designated current described in this specification. If the discharge current exceeds the specified value, discharge capacity could be extremely deteriorated or the battery could be heated.
- 2) The discharge temperature range should be the specified value in this specification.
- 3) When the Battery is stored for a long term, the Battery could become over discharged due to self discharge. The Battery with voltage less than over-discharge-protection-reset-voltage must be charged with small current in a few minutes. If the Battery voltage is not recovered to over-discharge-reset-voltage after small current charging in a few minutes, do not charge the Battery again.

### 5. Cautions for the Battery Storage

Store the Battery in the storage condition defined in this specification.

- Do not store the Battery in places of high temperature or under direct sunlight.
- Do not store the Battery in high humidity or in the place which may expose the Battery to rain or water.
- Do not put any combustibles around the Battery during storage.
- Store the Battery in the state of discharge (remaining capacity: 20-30%), when the Battery is stored for a long
- The Battery is a chemical product utilizing a chemical reaction, so the performance will be deteriorated not only through use but also with the passage of time even if it left unused.



# Lithium-ion Rechargeable Battery

---

## 6. Cautions for Disposal of the Lithium-ion Battery

- 1) Dispose the damaged Battery during the battery pack assembly process etc. after taking necessary steps to prevent external short-circuit by the following methods.
  - After insulating the terminals of the Battery with tape etc., dispose it under the law or ordinance of each local government.
- 2) As for the charged Battery, after discharging it with a resistor, dispose it by the above method.

## 7. Cautions for Marking

Please indicate Lithium-ion Battery safety cautions based on "Marking Guideline to ensure safety of storage batteries" on a battery pack, packing materials, and handling manuals. It should be indicated in the manner that users can completely and easily understand.

< Marking on battery caution label: YLE Recommendation >

Li-ion Rechargeable battery for INR14500A80.

Do not heat the battery or throw it into fire. Do not charge, use and leave the battery at the high temperature.

Do not deform, short-circuit, disassemble and modify the battery.

Do not allow the battery to be immersed in or wetted with water or sea-water.

Do not subject the battery to a strong impact or throw it. May cause heat, explosion and fire.

## 8. Cautions for Designing and Assembling the Battery Pack

- 1) Design the battery pack to ensure insulating the wires in the battery pack with the insulation tape, etc. to prevent internal short-circuit. Because the Battery external tube could be damaged or deformed by external force or heat.
- 2) Do not solder directly to the Battery. If the Battery is soldered directly, the insulation material may be melted or the safety mechanism may be damaged by heat. This may cause heat, explosion and fire. Be sure to observe the following to prevent a damage caused by the heat of soldering.
  - Spot-weld a connection tab with the pre-soldered lead wires to the Battery.
  - Solder the connection tab which is already spot-welded to the Battery. In this case, please be sure to consider tab length, shapes and the temperature / time conditions of soldering do not cause damages to the Battery by heat.
- 3) If the pack case is welded by ultrasonic welding, the condition must be set to keep the function of the Battery and protection circuit normally.
- 4) Protection circuit could be damaged by electrostatic discharge (ESD). Do anti-electrostatic treatment in the process of handling the protection circuit.
- 5) Battery pack materials.
  - As for resin case, use the resin comprising polycarbonate which has excellent electrolyte-resistant performance (YLE recommends the resin approved by UL standard flameproof 94V-0).
  - In the case of using solder, YLE recommends the no washing type solder (RMA).
  - As for other materials, YLE recommends to use materials approved by UL standard.
- 6) Process inspection - Be sure to implement the following inspection.
  - Inspection on the function of protection circuit.
  - Inspection on the voltage and the internal-resistance of the battery pack.
  - Inspection on the resistance of the thermistor, in the case of the battery packs using the thermistor.
  - Inspection on the outlook of the thermal fuse, in the case of the battery packs using the thermal fuse.
- 7) When you design the battery pack, a sealed construction should not be applied. Design the battery pack so that the protection circuit or the Battery in the battery pack can not be taken out easily by consumers.
- 8) In the case of cylindrical Battery:
  - Spot-weld the specified area shown in the attached drawing because the thin thickness area of (-) terminal could be damaged by spot-welding.
- 9) In the case of prismatic Battery:
  - When designing the battery pack using prismatic Battery, please note that the thickness of the Battery swells from the initial state of its shipment after use or storage.
- 10) In the case of assembling two or more Battery:
  - When assembling the battery pack, please use the Battery in the same rank according to the rank indication of the Battery.
  - Please select Battery with appropriate voltage so that the maximum voltage difference between the battery becomes less than 20mV.

# Lithium-ion Rechargeable Battery

## Product Drawing

Symbol	Date	Revision	Signed	Checked

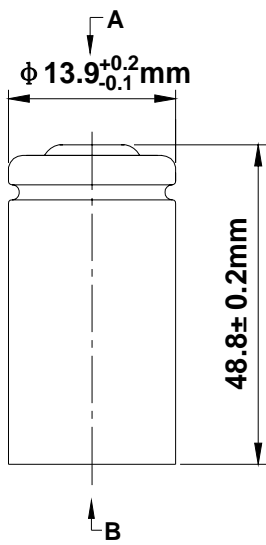

图1 Without PVC tube

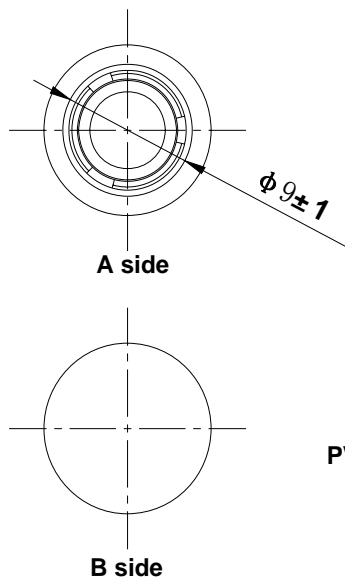

图2 With PVC tube

②	Outer Jacket	PVC	1			
①	Battery	INR14500A80	1			
Symbol	Name		Name	Qty	Process	Remark
Scale	Checked	Checked	Approved	Model NO.	INR14500A80	
Free				Name	Dimension Sketch	