

HWS300P-600P Series

Instruction Manual

BEFORE USING THE POWER SUPPLY UNIT

Be sure to read this instruction manual thoroughly before using this product. Pay attention to all warnings and cautions before using this product. Incorrect usage could lead to an electrical shock, damage to the unit or a fire hazard.

⚠ DANGER

Never use this product in locations where flammable gas or ignitable substances are present.

⚠ WARNING

- Do not touch this product or its internal components while it is in operation, or shortly after shut down. There may be high voltage or high temperature present and you may receive an electric shock or burn.
- When the product is operating, keep your hands and face away from it; an accident may injure you.
- Do not make unauthorised changes to this product, otherwise you may receive an electric shock and void your warranty.
- Do not use this product in the event of the emission of smoke or abnormal smell and sound etc. It might lead to fire and/or electric shock. In such cases, please contact us. Do not attempt repair by yourself, as it is dangerous for the user.
- Do not operate these products in the presence of condensation. It might lead to fire and/or electric shock.
- Do not drop or insert anything into the product. It might lead to a failure, fire and/or electric shock. Do not use the product which dropped.

⚠ CAUTION

- This power supply is designed for use within an end product.
- Confirm connections to input/output terminals and signal terminals are correct as indicated in the instruction manual before switching on.
- Input voltage, Output current, Output power, ambient temperature and ambient humidity should be kept within specifications, otherwise the product will be damaged.
- Do not operate and store this product in an environment where condensation might occur. In such case, waterproof treatment is necessary.
- Do not use this product in environment with a strong electromagnetic field, corrosive gas or conductive substances.
- For applications which require very high reliability (Nuclear related equipment, traffic control equipment, etc.) it is necessary to provide a fail safe mechanism in the end equipment.
- The information in this document is subject to change without prior notice. Please refer to the latest version of the data sheet, etc., for the most up-to date specifications of the product.
- No part of this document may be copied or reproduced in any form without prior written consent of Densai-Lambda.
- Do not inject abnormal voltages into the output or signal of this product. The injection of reverse voltage or over voltage exceeding nominal output voltage into the output or signal terminals might cause damage to internal components.
- The output of this product is considered to be a hazardous energy level (The voltage is 2V or more and the power is 240VA or more). It must not be made accessible to users. Protection must be provided for Service Engineers against indirect contact with the output terminals and/or to prevent tools being dropped across them. While working on this product, the AC input power must be switched off and the input and output voltage should be zero.
- This product has a built-in fan for air-cooling. Do not block the air intake and exhaust as this might lead to fire.

Note : CE MARKING

CE Marking when applied to a product covered by this handbook indicates compliance with the low voltage directive (2006/95/EC) in that it complies with EN60950-1.

DWG NO. : A237-04-01		
APPD	CHK	DWG
<i>m. Watami</i> 30. May. '08	<i>H. Ikeda</i> 29. May. '08	<i>H. Kawabara</i> 29. May. '08

1. Model name identification method

HWS 300P – 24

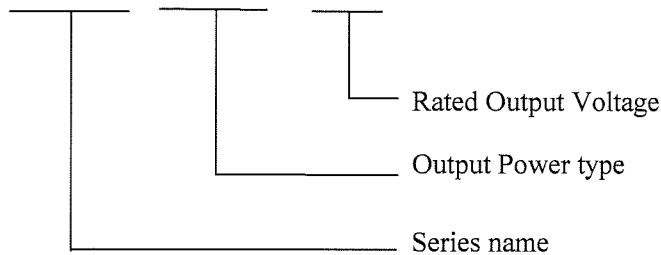

2. Terminal Explanation

Please pay extra attention to the wiring. Incorrect connection will damage the power supply.

2-1. Front Panel Explanation

HWS300P

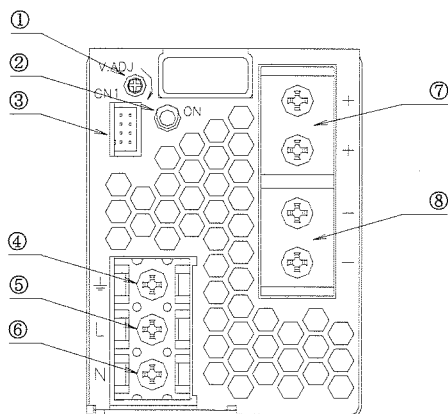

HWS600P

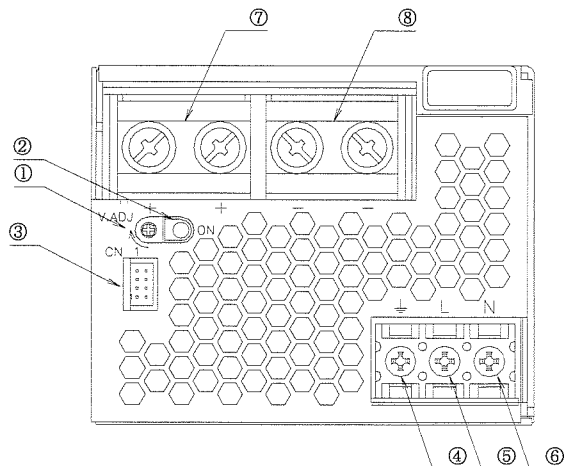

- ① V.ADJ : Output voltage adjustment trimmer.
(The output voltage rises when a trimmer is turned clockwise.)
- ② ON : Output (Power On) indication LED.
(The indicator turns on when the power supply output is in normal operating condition.)
- ③ CN1 : Remote ON/OFF control signal, Current balance signal (only as for HWS600P), Power fail signal.
(Refer to 2-2.)
- ④ \perp : Protective Earth terminal (Frame ground), M4 screw.
- ⑤ AC input terminal L : Live Line (Fuse in line), M4 screw.
- ⑥ AC input terminal N : Neutral line, M4 screw.
- ⑦ + : + Output terminal
(HWS300P: M4 screw x 2 / HWS600P: M5 screw x 2)
- ⑧ - : - Output terminal
(HWS300P: M4 screw x 2 / HWS600P: M5 screw x 2)

2-2. CN1 Connector pin Configuration and Function

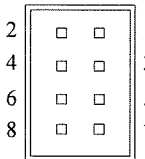
	Pin No.	Configuration	Function
	1	COM	GND for PC signals (Only as for HWS600P. HWS300P is NC.)
	2	PC	Current balance terminal. (For output current balancing in parallel operation. Only as for HWS600P. HWS300P is NC.)
	3	NC	No connect
	4	NC	No connect
	5	CNT	Remote ON/OFF control terminal. (Power supply ON/OFF control with an external signal.)
	6	TOG	GND for CNT and PF signals. (Same as Pin No.8)
	7	PF	Power fail signal (PF signal) output terminal. (Uses the open collector method. As the output voltage drops, or Fan stops, "Power Fail" terminal will output "High".)
	8	TOG	GND for CNT and PF signals. (Same as Pin No.6)

CN1 Connector & Housing & Terminal Pin

PART DESCRIPTION	PART NAME	MANUFACT
PIN HEADER	S8B-PHDSS	J.S.T.

SOCKET HOUSING	PHDR-08VS	J.S.T.
TERMINAL PINS	SPHD-002T-P0.5(AWG28~24) or SPHD-001T-P0.5(AWG26~22)	J.S.T.
HAND CRIMPING TOOL	YRS-620(SPHD-002T-P0.5) or YC-610R(SPHD-001T-P0.5)	J.S.T.

※Attached connector is mounted on CN1 at shipment. (CNT-TOG is short)

3. Terminal Connection Method

Please pay extra attention to the wiring. Incorrect connection will damage the power supply.

- When connecting input and output wiring, and CN1, input AC-Line should be off.
- Input wiring and output wiring shall be separated to improve noise sensibility.
- The protective earth (PE) must be connected to the \perp terminal or chassis.
- Remote ON/OFF control lines shall be twisted or used shielded wires. Separate from load line.
- Output current of each terminal screw shall be less than 40A for HWS300P. And shall be less than 60A for HWS600P.

HWS300P Panel Side (Common HWS600P)

• Basic connection

Connect "CNT" terminal to "TOG" terminal with the attached connector.

• PF signal output required

Open collector method shown below shall be used. "TOG" terminal is ground for "PF" terminal.

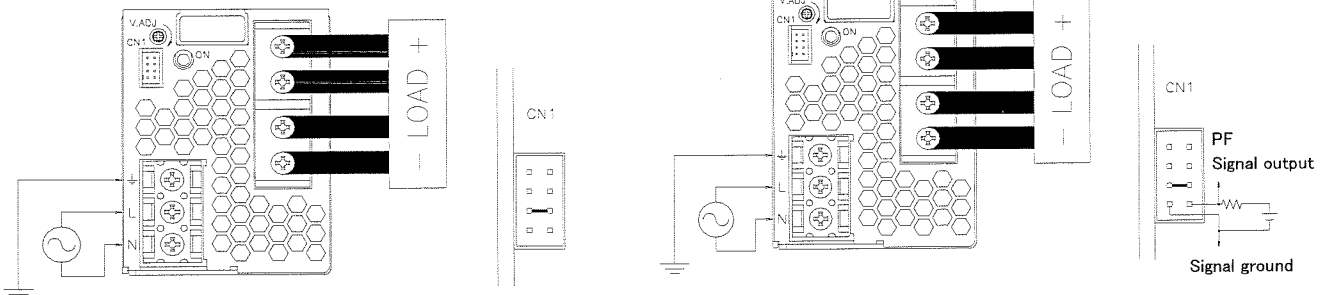

• Remote ON/OFF control required

"TOG" terminal is ground for "CNT" terminal. Connect an outside signal between CNT-TOG.

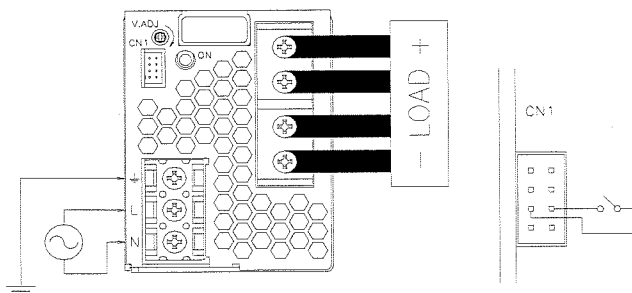

4. Functions and Precautions

4-1. Input Voltage Range

Input voltage range is single phase 85 ~ 265VAC (47 ~ 63Hz) or 120 ~ 330VDC. Input voltage, which is out of specification, may cause unit damage. Rated input voltage for safety standard application is 100 ~ 240VAC(50/60Hz).

4-2. Output Voltage Range

Output voltage is set to the rated voltage value at shipment. V.ADJ trimmer on the front panel side is used to adjust the output voltage within the range specified.

Output voltage range is within $-20\% \sim +10\%$ of rated output voltage.

To turn the trimmer clockwise, the output voltage will be increased. Take note when the output voltage is increased excessively, over voltage protection (OVP) function may trigger and output voltage will be shut down.

When output voltage increased, average output power and peak output power have to use less than specification.

4-3. Over Voltage Protection (OVP)

The OVP function (Inverter shutdown method, manual reset type) is provided. OVP function operates within 115-135% of the rated output voltage value, and the output will be shut down when OVP function trigger. To reset OVP, remove the input of power supply for a few minutes, and then re-input. Or, use CNT reset (remote ON/OFF : OFF to ON). OVP value is fixed and not to be adjusted externally.

Never apply more than rated output voltage to output terminal, which may lead damage to power supply. In the case of inductive load, use decoupling diode at output line.

4-4. Delay Shut Down

This product have a delay shut down function provided to protect power supply and equipment at the time of the consecutive peak current. When the product operate peak current for more than 5 seconds, delay shut down function operates and the output will be shut down.

To reset delay shut down, remove the input of power supply for a few minutes, and then re-input. Or, use CNT reset (remote ON/OFF : OFF to ON).

Delay Shut Down Time value is fixed and not to be adjusted externally.

Use it about the peak electricity in specifications range. The details see at "4-14. Output Peak Power".

4-5. Over Current Protection (OCP)

The OCP function (manual reset type) is provided. Output will be shut down in condition over current or output short-circuit. To reset OCP, remove the input of power supply for a few minutes, and then re-input. Or, use CNT reset (remote ON/OFF : OFF to ON).

Also avoid over current condition or output short-circuit. Otherwise the product will be damage.

OCP value is fixed and not to be adjusted externally.

4-6. Over Temperature Protection (OTP)

The OTP function (manual reset type) is provided. When ambient or internal temperature rises abnormally, OTP function operates and output will be shut down. To reset OTP, remove the input and cool it down. Then re-input.

Or, use CNT reset after cool it down(remote ON/OFF : OFF to ON).

4-7. Low Output Detection Circuit (PF)

Low output voltage detection circuit is provided. Power Fail (PF) signal will turn "High" level to indicate the abnormal status when the output voltage becomes within 65 ~ 80% of rated value caused by either the drop or brownout of the input voltage or OCP, OVP, Delay Shut Down and OTP etc function operation. When the built-in Fan of this power supply unit stops, PF signal will turn to "High". The PF signal is isolated from input and output by a photo-coupler. It uses the open collector method shown in below.

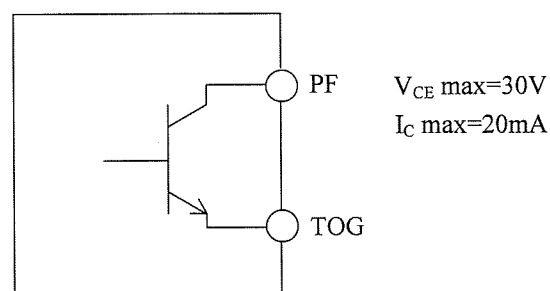

4-8. Remote ON/OFF Control

Remote ON/OFF control is provided.

Using this function, output ON/OFF is allowed to control without input voltage ON/OFF. The output is turned to ON when TOG and CNT terminals are shorted, and the output is turned to OFF when these terminals are opened. When the function is not used, connect TOG and CNT terminals. The standards for this function are as follows. "TOG" terminal is return for "CNT" terminal.

- (1) TTL compatible. The maximum input voltage to CNT terminal is 12V, and the maximum allowable reverse voltage is $-1.0V$. The sink current for CNT terminal is 3.5mA.
- (2) A switch and relay or a transistor can be used as ON/OFF switch.
- (3) Remote ON/OFF control circuit is isolated from the input and output by a photo-coupler and can be controlled regardless of the output potential (+ or -). Connect TOG terminal to ground of control signal.

The mode of control

CNT Level for TOG Terminal	Output	Built-in Fan
Short or L (0V - 0.8V)	ON	Rotate
Open or H (2.4V - 12V)	OFF	Stop

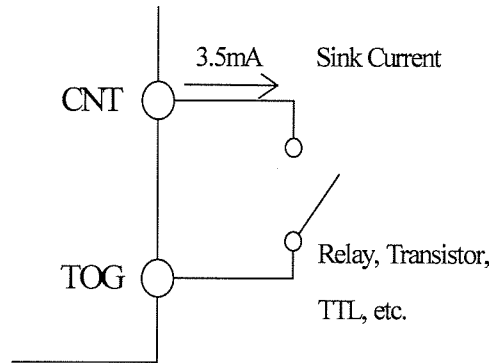

4-9. Output Ripple & Noise

The standard specification for maximum ripple value is measured specified measurement circuit (JEITA-RC9131A). When load lines are longer, ripple becomes larger. In this case, electrolytic capacitor, film capacitor, etc. might be necessary to use across the load terminal. The output ripple cannot be measure accurately if the probe ground lead of oscilloscope is too long.

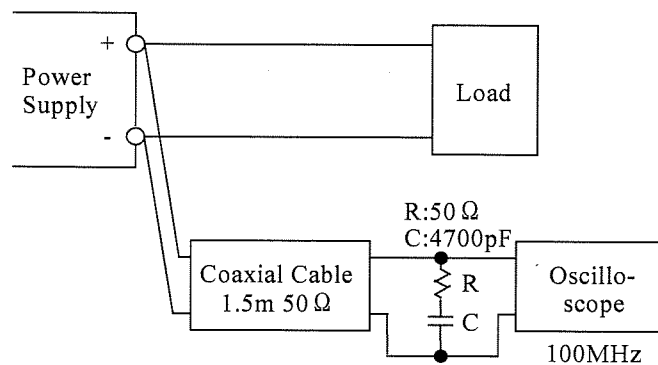

4-10. Series Operation

For series operation, both method (A) and (B) are possible.
 There might be a step in the output rise waveform during series operation.

Method (A)

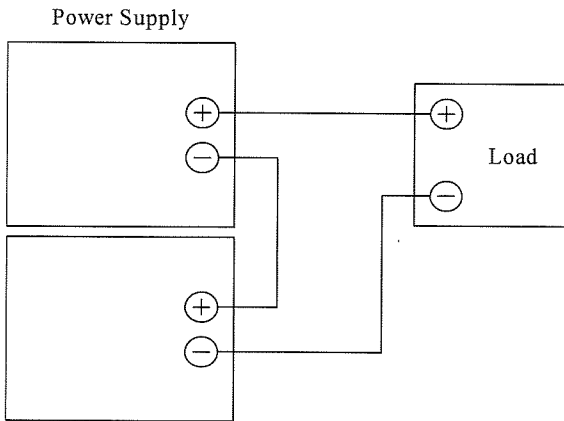

Method (B)

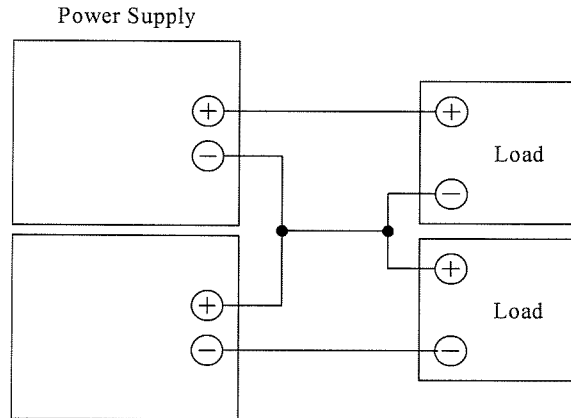

4-11. Parallel Operation

There are operation Mode (A) and (B).
 As for HWS300P, Mode (B) is possible. As for HWS600P, Mode (A) and (B) are possible.

(A) To Increase the Output Current(only as for HWS600P)

Current balancing function is provided. Connecting PC to PC terminal and COM to COM terminal, the current balancing function activates and output current of each power supply is equivalently supplied to load. Wires to PC terminals, COM terminals shall be as short as possible and same length and twisted.

Parallel operation is possible up to 2 units.

1. Adjust the output voltage of each power supply to be same value within 100mV.
2. Use same length and type of wires for all load lines.
3. Peak output current and average output current use less than specification for all paralleled models.

(B) To Use as a Backup Power Supply

1. Adjust the output voltage of each power supply to be same value.
2. Set power supply output voltage higher by the forward voltage drop of diode.
3. Use within the specifications for output voltage and output power.

(A) To Increase the Output Current
 (only as for HWS600P)

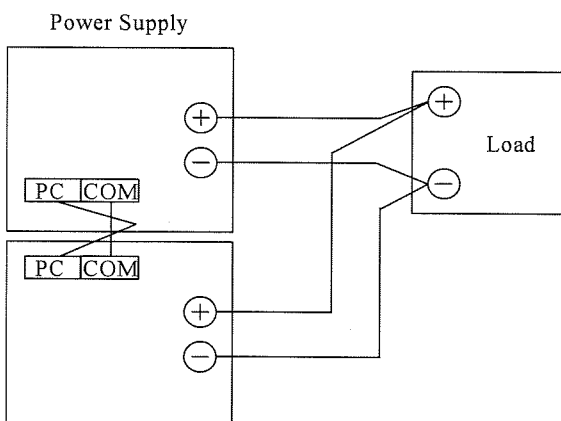

(B) To Use as a Backup Power Supply

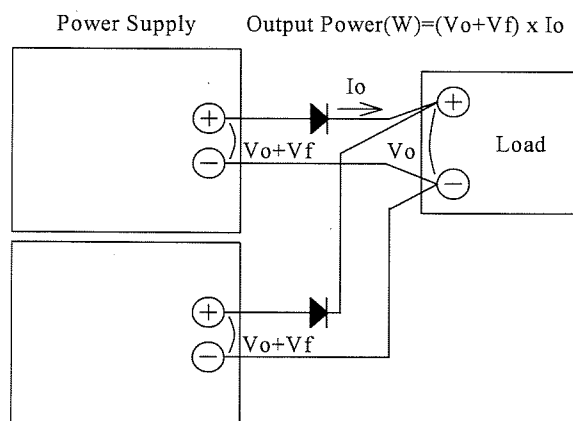

4-12. Isolation Test

Isolation resistance between output and \perp (Frame ground) shall be more than $100M\Omega$ at 500VDC and between output and CNT·PF shall be more than $10M\Omega$ at 100VDC. For safety operation, voltage setting of DC isolation tester must be done before the test. Ensure that it is fully discharged after the test.

• Output ~ \perp (Frame ground) : 500VDC $100M\Omega$ or more

• Output ~ CNT · PF : 100VDC $10M\Omega$ or more

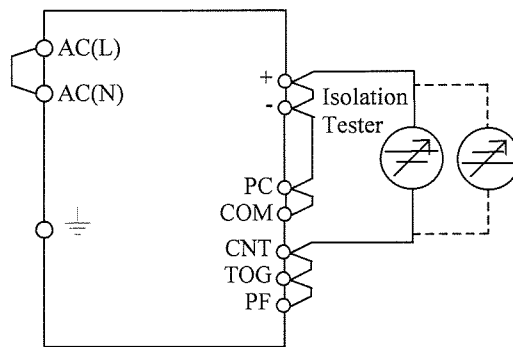
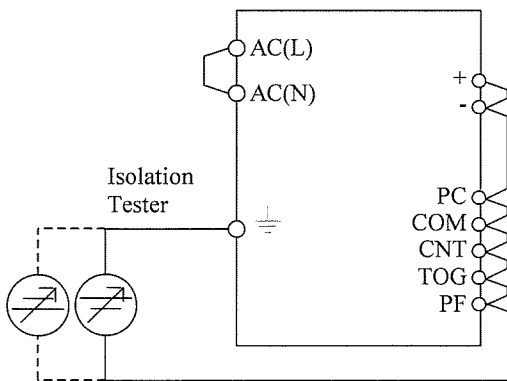

Note 1. "PC" and "COM" are NC in HWS300P.

4-13. Withstand Voltage

This series is designed to withstand 3.0kVAC between input and output, 2.5kVAC between input and \perp (Frame ground), 500VAC between output and \perp (Frame ground), and 100VAC between output and CNT·PF terminal each for 1 minute. When testing withstand voltage, set current limit of withstand voltage test equipment at 20mA.

(Output- \perp (Frame ground) and Output-CNT·PF: 100mA).

The applied voltage must be gradually increased from zero to testing value and then gradually decreased for shut down. When timer is used, the power supply may be damaged by high impulse voltage at timer switch on and off. Connect input and output as follows.

In the test by state of output open, there is a thing that output voltage is generated momentarily.

Input ~ Output (dotted line) : 3.0kVAC 1min. (20mA)

Input ~ \perp (Frame ground) (solid line) : 2.5kVAC 1min. (20mA)

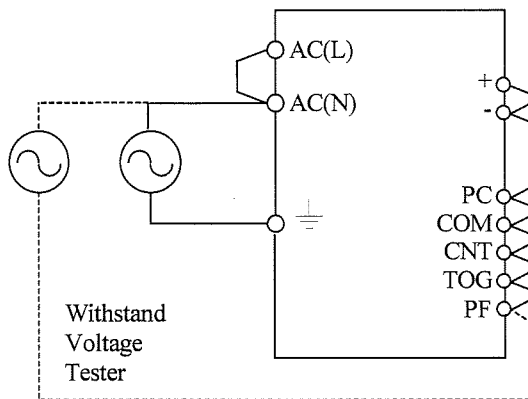

Output ~ $\frac{\perp}{\perp}$ (Frame ground) : 500VAC 1min. (100mA)

Output ~ CNT·PF : 100VAC 1min. (100mA)

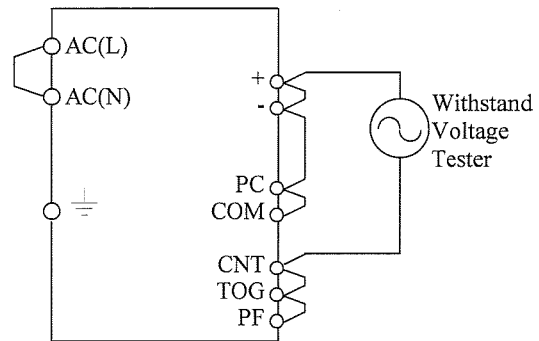
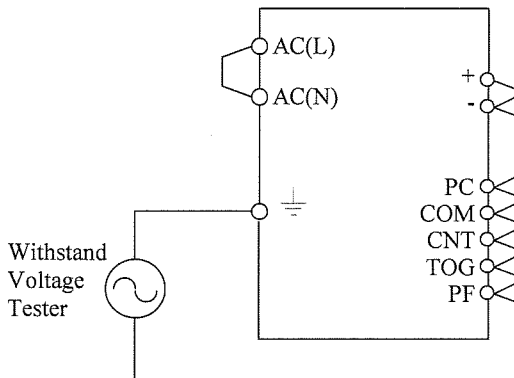

Note 1, "PC" and "COM" are NC in HWS300P.

Note 2, This product have monolithic ceramic capacitor in secondary circuit to frame ground.

Some of the withstand voltage tester may generate high voltage at the matching with monolithic ceramic capacitor and may cause the unit damage.

So, please check the waveform of test voltage.

4-14. Output Peak Power

This product must be use to satisfy (a) and (b).

Allowable peak output operating time is less than 5sec.

When the product operate peak power for more than 5 sec, the delay shut down function operates and the output will shut down.

Peak output power and average output power use less than specification.

Peak output power is limited depending on Duty. The details see at (b).

The product might be damage to use beyond the limits of (a) and (b).

When using pulse load, a noise may be heard from power supply unit. Please evaluate and check before using.

(a) Expression of relations

A formula about Duty

$$Duty = \frac{\tau}{T} \times 100(\%)$$

A formula about average output power

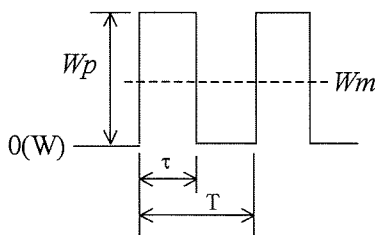

$$W_{avg} \geq W_m = \frac{W_p \times \tau}{T}$$

W_p : Peak output power (W)
 W_{avg} : Average output power of Specification (W)
 W_m : Average output power (W)

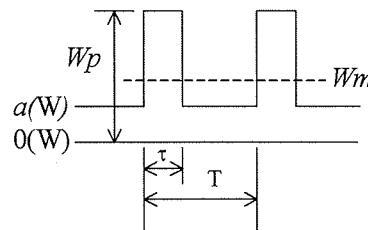

$$W_{avg} \geq W_m = \frac{(W_p - a) \times \tau}{T} + a$$

τ : Pulse width of peak output power (sec)
 (Operating time at peak output)
 T : Period (sec)
 Duty : The duty is pulse width of peak output power of one period(%)

(b) Peak output power VS Duty
HWS300P

Vin:100VAC(dotted line)
Vin:200VAC(solid line)

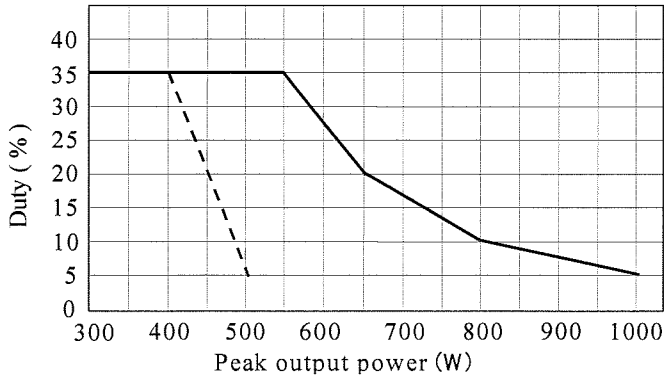

HWS600P

Vin:100VAC(dotted line)
Vin:200VAC(solid line)

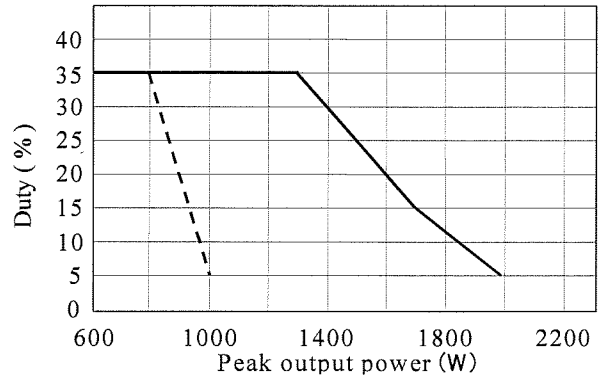

5. Mounting Directions

5-1. Output Derating according to the Mounting Directions.

Recommended standard mounting method is (A). Method (B) is also possible. Refer to the derating below.

HWS300P

(A) Standard Mounting

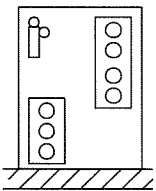

(B)

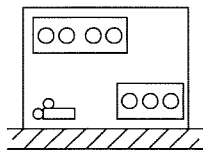

(C) Inhibit

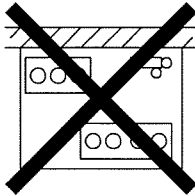

(D) Inhibit

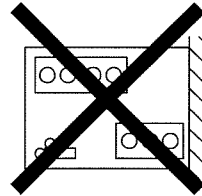

HWS600P

(A) Standard Mounting

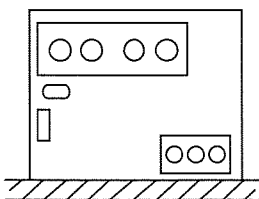

(B)

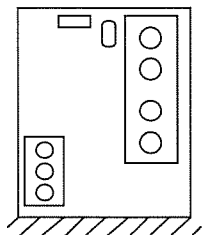

(C) Inhibit

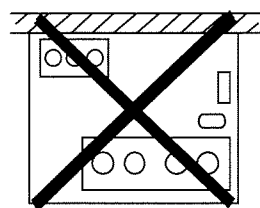

(D) Inhibit

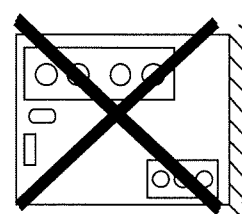

5-2. Output Derating

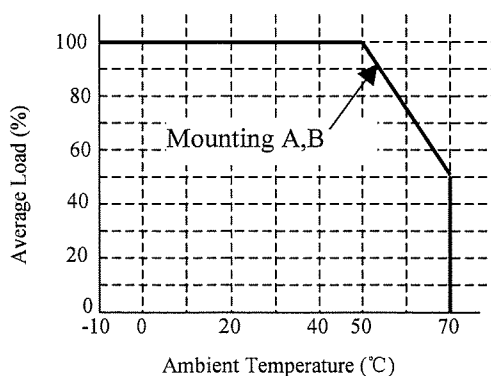

Ta(°C)	Average Load (%)	
	Mounting(A)	Mounting(B)
-10 ~ +50	100	
+70	50	

Note 1, Peak power does not have the derating.

5-3. Mounting Method

- (1) Forced air-cooling type power supply.
 This power supply has ventilating holes on the front and back side panels. Keep these two areas freely as much as possible.
- (2) The maximum allowable penetration is 6mm.
 Incomplete thread of mounting screw should not be penetrated.
- (3) Recommended torque for mounting screw :
 M4 screw : 1.27 N · m (13.0kgf · cm)

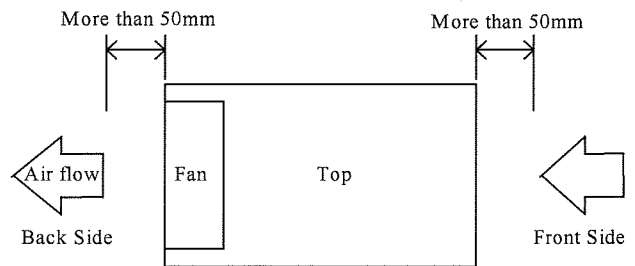

6. Wiring Method

- (1) The output load line and input line shall be separated to improve noise sensitivity.
- (2) Use all lines as thick and short as possible to make lower impedance.
- (3) Attaching a capacitor to the load terminals can eliminate noise.
- (4) For safety and EMI considerations, connect \varnothing terminal to the mounting set ground terminal.
- (5) Recommended torque for the terminal ;
 HWS600P Output terminal (M5 screw) : 2.50 N · m (25.5kgf · cm)
 HWS300P Input, Output terminal & HWS600P Input terminal (M4 screw) : 1.27 N · m (13.0kgf · cm)

[The PHD connector manufacture method]

This product is using SPHD-001T-P0.5 or SPHD-002T-P0.5 connector made from JAPAN SOLDERLESS TERMINAL MFG CO LTD.

Regarding to manufacture of a connector, it becomes the regulation as following.

a). Applicable Wire and Crimping tool

Wire size to use for SPHD-001T-P0.5 is AWG#26 ~ AWG#22 and insulation outer diameter is ϕ 1.0 ~ ϕ 1.5 mm.

Wire size to use for SPHD-002T-P0.5 is AWG#28 ~ AWG#24 and insulation outer diameter is ϕ 0.9 ~ ϕ 1.5 mm.

Crimping tool is as blow.

Crimping tool	Crimping applicator	Dies
AP-K2 or AP-KS	MKS-LS-10 or MKS-L-10	SPHD-001-05/SPHD-002-05

b). Crimping Operation

The reference value of wire strip is 2.3mm. As wire strip length differs depending on type of wire and crimping method, decide the best wire strip length considering processing condition. When wire is stripped, do not damage or cut off wire conductors.

Table of crimp height

SPHD-001T-P0.5

Wire Size	Insulation O.D (mm)	Crimp height (mm)	
		Conductor part	Insulation part
AWG#26	1.3	0.60 ~ 0.70	1.7
AWG#24	1.5	0.65 ~ 0.75	1.8
AWG#22	1.4	0.70 ~ 0.80	1.8

SPHD-002T-P0.5

Wire Size	Insulation O.D (mm)	Crimp height (mm)	
		Conductor part	Insulation part
AWG #28	1.2	0.55 ~ 0.60	1.6
AWG #26	1.3	0.60 ~ 0.65	1.7
AWG #24	1.5	0.62 ~ 0.67	1.8

Note 1. Crimp height at wire barrel should be set to pre-determined dimensions.

Note 2. Adjust crimp height at wire insulation barrel to the extent that wire insulation is slightly pressed, and set it so that crimping is not excessivary.

Note 3. Crimping condition at wire insulation barrel is as below Fig.1.

Note 4. For AWG#28,#26,#24, use UL1007 type. For AWG#22, use UL1061 type.

Fig.1

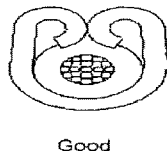
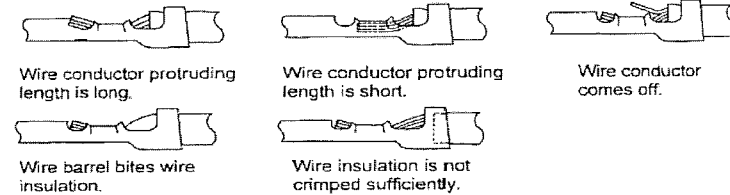

Fig.2: Examples of defective crimping



Check of crimping appearance visually for correct crimping as referring to above Fig.2
 Check the tensile strength at crimped part when operation finishes.

Table of tensile strength at crimped part.

SPHD-001T-P0.5

Wire size	Requirement N min.	Actual value N
AWG#26	20	39.2 ~ 45.1
AWG#24	30	68.6 ~ 74.5
AWG#22	40	92.1 ~ 96.0

SPHD-002T-P0.5

Wire size	Requirement N min.	Actual value N
AWG#28	15	27.0 ~ 34.3
AWG#26	20	44.1 ~ 48.0
AWG#24	30	66.6 ~ 71.5

c). Inserting contact into housing

Inserting crimped contact into housing

- (1) Do not apply any pulling force to crimped part, and insert contact parallel to housing.
- (2) Insert contact into housing without stopping to innermost.
- (3) Check secure locking per each insertion by pulling wire softly in order to check that contact does not come off housing. Besides, check whether there is the backlash in the direction of insertion axis.

Defect example of slating insertion

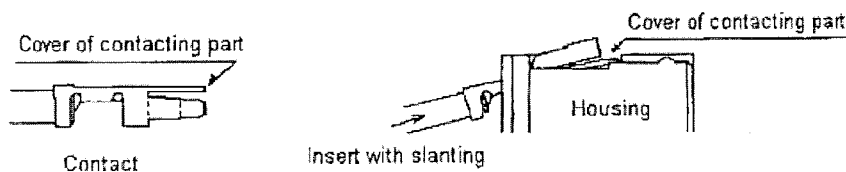

d). Mating and Unmating Connector

- (1) Inserting connector

Hold receptacle housing securely and insert into header straight against to header post until click sounds.

- (2) Unmating connector

Hold all wires securely and fix receptacle housing by fingers so as to pry, and then, withdraw it on the mating axis.

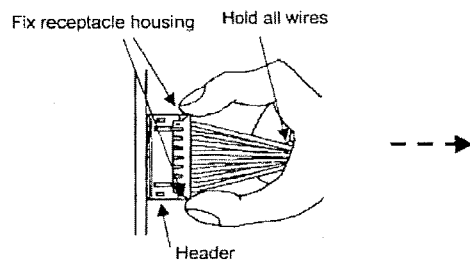

e). Routing of Wire

Routing wire so as not to apply external force to connector except force to such an extent that wire slightly buckles, considering an enough length to route and fixing of wire.

7. External Fuse Rating

Refer to the following fuse rating when selecting the external fuses that are to be used on input line. Surge current flows when line turns on. Use slow-blow or time-lag type fuse, not fast-blow fuse. Fuse rating is specified by in-rush current value at line turn-on. Do not select the fuse according to input current (RMS.) values under the actual load condition.

HWS300P : 12A
HWS600P : 20A

8. Fan life expectancy

The Fan life has limitation. Therefore, periodic maintenance by exchanging the life-expired fan is required for the power supply. The following figure shows the Fan life. The built-in Fan replacement is charged. Please contact to our sales office for Fan replacement.

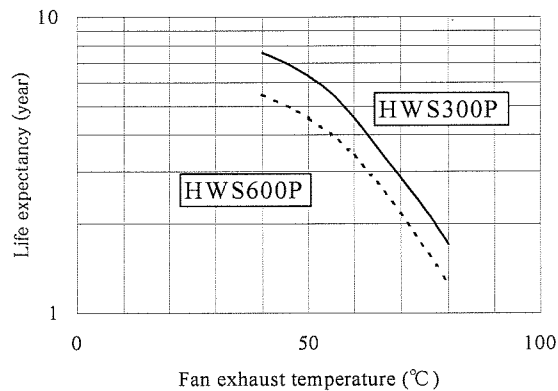

Measurement point of fan exhaust temperature

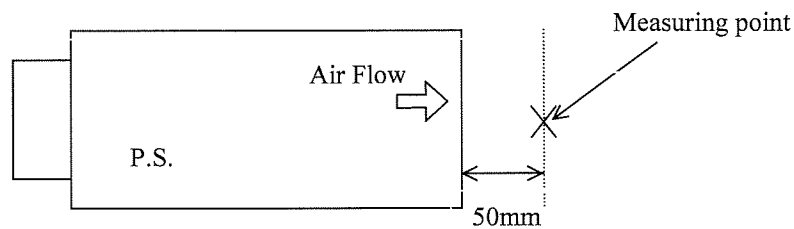

The difference between the intake temperature and the exhaust temperature of the Power Supply at average load.

HWS300P : 4°C
HWS600P : 8°C

9. Before concluding that the unit is at fault...

Before concluding that the unit is at fault, make the following checks.

- (1) Check if the rated input voltage is connected.
- (2) Check if the wiring of input and output is correct.
- (3) Check if the I/O terminal connection is properly tightened by regulated torque.
- (4) Check if the wire thickness is enough.
- (5) Check if the output voltage control (V.adj) is properly adjusted. OVP might be triggered and output is shut down.
- (6) If use function of the Remote ON/OFF control, check if the Remote ON/OFF control connector is not opened.
If in open condition, power supply will not output.
- (7) Check if the built-in Fan is not stopped. Is Fan stopped by something irregulars or etc?
If Fan stops, the PF signal turn "High" level and OTP might be activated.
- (8) Power supply has ventilating holes on the front and back panels. Check if there is any irregulars or dust, etc.
- (9) Is the chassis of power supply hot abnormally? The output is shut down by OTP operation.
Please re-input after the unit to cool down sufficiently.
- (10) Check if the output current and output power does not over specification.
- (11) Audible noise may be heard when input voltage waveform is not sinusoidal.
- (12) Audible noise may be heard during dynamic load operation.

10. Range of free warranty

This product is warranted for a period of 5 years from the date of shipment. As for the breakdown under a normal use during free warranty term, repair is at free of charge. However, the built-in Fan replacement is charged.

Please contact to our sales office for Fan replacement. Please see "8. Fan life expectancy" for the exchange time of Fan.

Conditions of usage at the free of charge warranty are as follows.

- (1) Average operating temperature (ambient temperature of the power supply unit) is under 40°C
- (2) Average load factor is 80% or less.
- (3) Mounting method : Standard mounting.

However, the maximum rating is within the output derating.

Following cases are not covered by warranty.

- (1) Improper usage like dropping products, applying shock and defects from operation exceeding specification of the units.
- (2) Defects resulting from natural disaster (fire, flood).
- (3) Unauthorized modifications or repair by the buyers defects not cause by DENSEI LAMBDA.