

A20B-V4E01R



- R : Red
- 01 : 1NC
- E : Standard
- 4 : Mushroom
- V : Emergency Stop
- A20B : Type

Product Specifications

- Mechanical life : >0.25 million operations
- Electrical life : >0.1 million operations
- Rated insulation voltage : 600V
- Rated thermal current : 10A
- Insulation resistance : 100MΩ
- Dielectric strength : 2500V AC , 1 minute
- Panel thickness : 0.8mm ~ 6mm
- Degree of protection : IP 65
- Storage temperature : -45°C to +85°C
- Operating temperature : -25°C to +55°C

Screw Type Emergency Stop Switches

Hole Dia

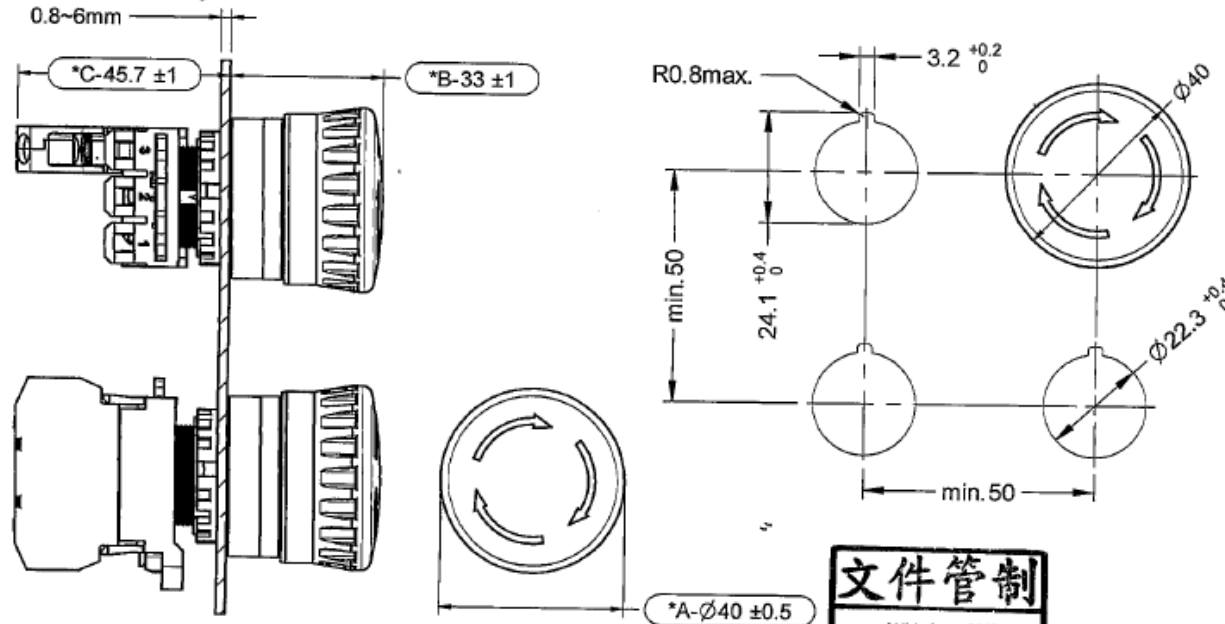

Contact Block Mounting Position

Contact	Operator Position		
	Free	Push	—
1			
2			
3	NC	●	

●=On(closed contact)
blank=Off(open contact)

Contact Ratings

Rated Insulation Voltage		600V			
Rated Thermal Current		10A			
Operating Voltage		24V	120V	240V	380V
AC	Resistive Load (AC-12)	10A	10A	6A	2A
	Inductive Load (AC-15)	10A	6A	3A	1.9A
DC	Resistive Load (DC-12)	8A	2.2A	1.1A	—
	Inductive Load (DC-13)	4A	1.1A	0.55A	—

Distributed by Conrad Electronic SE

文件管制
MAY 14, 2013
文管中心

DECA

PART NAME	UNIT	SCALE
Emergency Stop Switches (1NC)	MM	1 : 0.7
DRAWING NO.		SHEET
A20B-V4E01R		1/1

E			2013/05/14	Jim	Kingdom	吳智遠
REV.	NOTE	CHANGE DESCRIPTION	DATE	DESIGN	CHECK	APPROVE