

LM2767 Switched Capacitor Voltage Converter

Check for Samples: [LM2767](#)

FEATURES

- Doubles Input Supply Voltage
- SOT-23 5-Pin Package
- 20Ω Typical Output Impedance
- 96% Typical Conversion Efficiency at 15mA

APPLICATIONS

- Cellular Phones
- Pagers
- PDAs, Organizers
- Operational Amplifier Power Suppliers
- Interface Power Suppliers
- Handheld Instruments

DESCRIPTION

The LM2767 CMOS charge-pump voltage converter operates as a voltage doubler for an input voltage in the range of +1.8V to +5.5V. Two low cost capacitors and a diode are used in this circuit to provide at least 15 mA of output current.

The LM2767 operates at 11 kHz switching frequency to avoid audio voice-band interference. With an operating current of only 40 μA (operating efficiency greater than 90% with most loads), the LM2767 provides ideal performance for battery powered systems. The device is manufactured in a SOT-23 5-pin package.

Basic Application Circuit

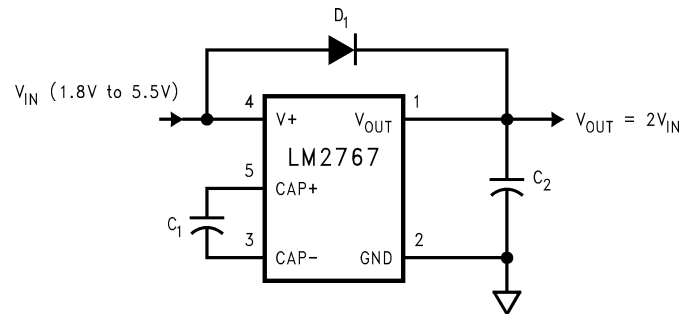

Figure 1. Voltage Doubler



Please be aware that an important notice concerning availability, standard warranty, and use in critical applications of Texas Instruments semiconductor products and disclaimers thereto appears at the end of this data sheet.

All trademarks are the property of their respective owners.

Connection Diagram

5-Pin Small Outline Package

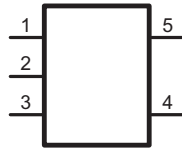

Figure 2. DBV Package Top View



Figure 3. Actual Size

PIN FUNCTIONS

Pin	Name	Function
1	V _{OUT}	Positive voltage output.
2	GND	Power supply ground input.
3	CAP–	Connect this pin to the negative terminal of the charge-pump capacitor.
4	V+	Power supply positive voltage input.
5	CAP+	Connect this pin to the positive terminal of the charge-pump capacitor.



These devices have limited built-in ESD protection. The leads should be shorted together or the device placed in conductive foam during storage or handling to prevent electrostatic damage to the MOS gates.

ABSOLUTE MAXIMUM RATINGS⁽¹⁾⁽²⁾

Supply Voltage (V+ to GND, or V+ to V _{OUT})	5.8V
V _{OUT} Continuous Output Current	30 mA
Output Short-Circuit Duration to GND ⁽³⁾	1 sec.
Continuous Power Dissipation (T _A = 25°C) ⁽⁴⁾	400 mW
T _{JMax} ⁽⁴⁾	150°C

- (1) Absolute maximum ratings indicate limits beyond which damage to the device may occur. Electrical specifications do not apply when operating the device beyond its rated operating conditions.
- (2) If Military/Aerospace specified devices are required, please contact the TI Sales Office/ Distributors for availability and specifications.
- (3) V_{OUT} may be shorted to GND for one second without damage. For temperatures above 85°C, V_{OUT} must not be shorted to GND or device may be damaged.
- (4) The maximum allowable power dissipation is calculated by using $P_{DMax} = (T_{JMax} - T_A)/\theta_{JA}$, where T_{JMax} is the maximum junction temperature, T_A is the ambient temperature, and θ_{JA} is the junction-to-ambient thermal resistance of the specified package.

OPERATING Ratings

θ_{JA} ⁽¹⁾	210°C/W	
Junction Temperature Range	–40°C to 100°C	
Ambient Temperature Range	–40°C to 85°C	
Storage Temperature Range	–65°C to 150°C	
Lead Temp. (Soldering, 10 sec.)	240°C	
ESD Rating	Human Body Model ⁽²⁾	2kV
	Machine Model ⁽²⁾	200V

- (1) The maximum allowable power dissipation is calculated by using $P_{DMax} = (T_{JMax} - T_A)/\theta_{JA}$, where T_{JMax} is the maximum junction temperature, T_A is the ambient temperature, and θ_{JA} is the junction-to-ambient thermal resistance of the specified package.
- (2) The human body model is a 100pF capacitor discharged through a 1.5k Ω resistor into each pin. The machine model is a 200pF capacitor discharged directly into each pin.

ELECTRICAL CHARACTERISTICS

Limits in standard typeface are for $T_J = 25^\circ\text{C}$, and limits in **boldface** type apply over the full operating temperature range. Unless otherwise specified: $V_+ = 5\text{V}$, $C_1 = C_2 = 10\ \mu\text{F}$.⁽¹⁾

Symbol	Parameter	Condition	Min	Typ	Max	Units
V_+	Supply Voltage		1.8		5.5	V
I_Q	Supply Current	No Load		40	90	μA
I_L	Output Current	$1.8\text{V} \leq V_+ \leq 5.5\text{V}$	15			mA
R_{OUT}	Output Resistance ⁽²⁾	$I_L = 15\ \text{mA}$		20	40	Ω
f_{OSC}	Oscillator Frequency	See ⁽³⁾	8	22	50	kHz
f_{SW}	Switching Frequency	See ⁽³⁾	4	11	25	kHz
P_{EFF}	Power Efficiency	$R_L (5.0\text{k})$ between GND and OUT		98		%
		$I_L = 15\ \text{mA}$ to GND		96		
V_{OEFF}	Voltage Conversion Efficiency	No Load		99.96		%

- (1) In the test circuit, capacitors C_1 and C_2 are $10\ \mu\text{F}$, 0.3Ω maximum ESR capacitors. Capacitors with higher ESR will increase output resistance, reduce output voltage and efficiency.
- (2) Specified output resistance includes internal switch resistance and capacitor ESR. See the details in the application information for positive voltage doubler.
- (3) The output switches operate at one half of the oscillator frequency, $f_{\text{OSC}} = 2f_{\text{SW}}$.

Test Circuit

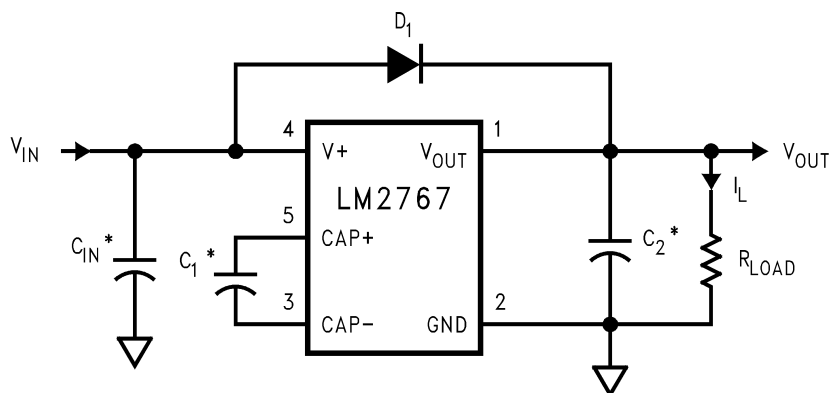

* C_{IN} , C_1 , and C_2 are $10\ \mu\text{F}$ OS-CON capacitors.

Figure 4. LM2767 Test Circuit

Typical Performance Characteristics

(Circuit of Figure 4, $V_{IN} = 5V$, $T_A = 25^\circ C$ unless otherwise specified)

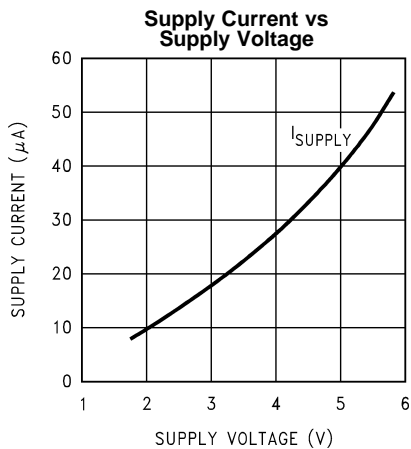

Figure 5.

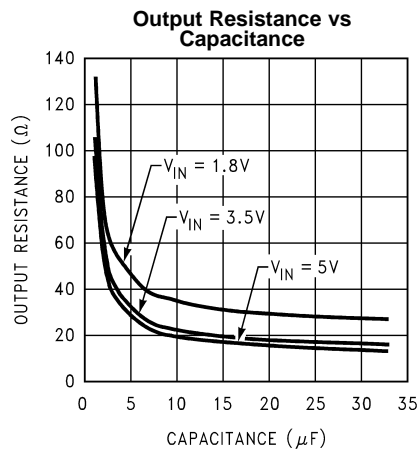

Figure 6.

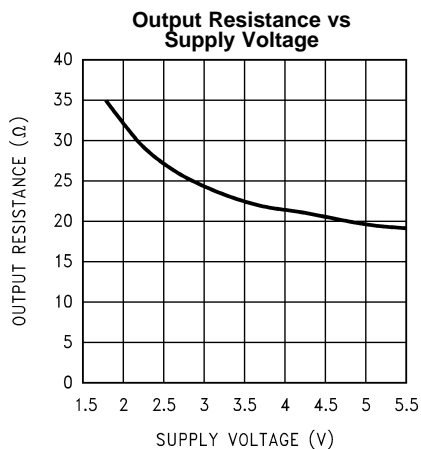

Figure 7.

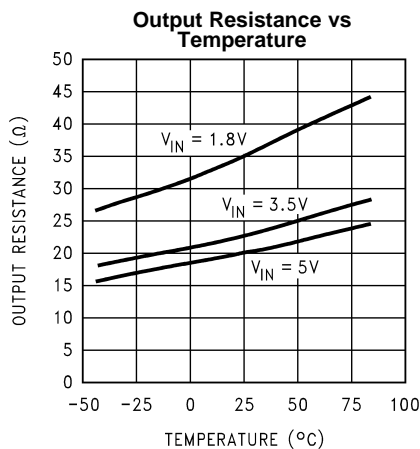

Figure 8.

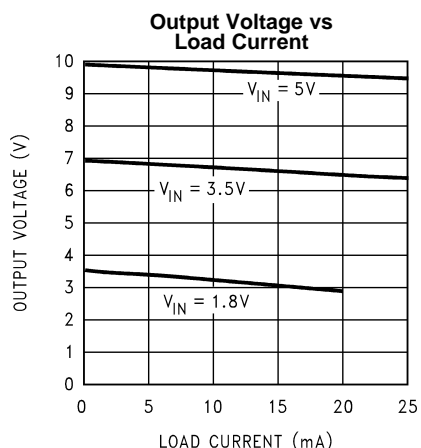

Figure 9.

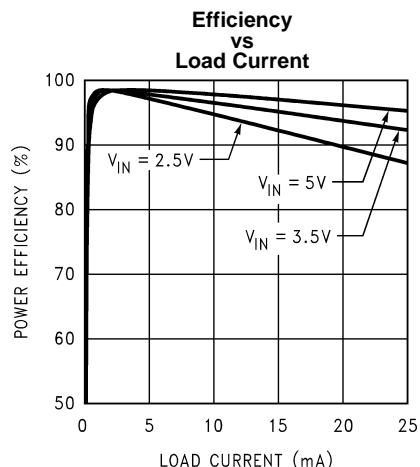

Figure 10.

Typical Performance Characteristics (continued)

(Circuit of Figure 4, $V_{IN} = 5V$, $T_A = 25^\circ C$ unless otherwise specified)

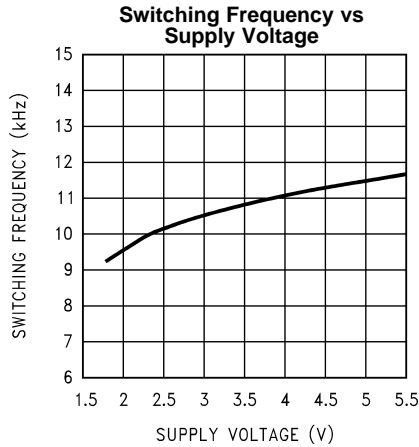

Figure 11.

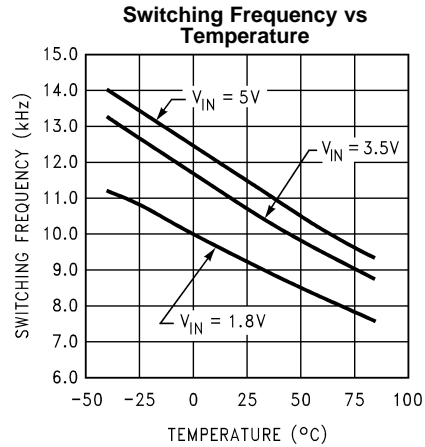

Figure 12.

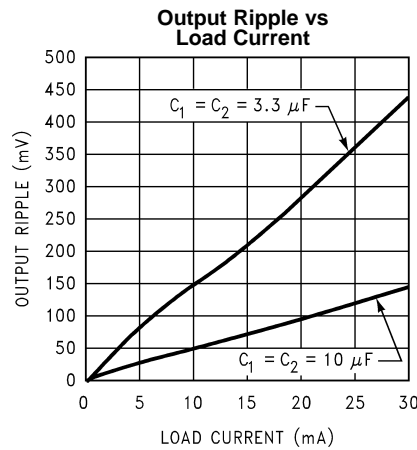

Figure 13.

CIRCUIT DESCRIPTION

The LM2767 contains four large CMOS switches which are switched in a sequence to double the input supply voltage. Energy transfer and storage are provided by external capacitors. Figure 14 illustrates the voltage conversion scheme. When S_2 and S_4 are closed, C_1 charges to the supply voltage $V+$. During this time interval, switches S_1 and S_3 are open. In the next time interval, S_2 and S_4 are open; at the same time, S_1 and S_3 are closed, the sum of the input voltage $V+$ and the voltage across C_1 gives the $2V+$ output voltage when there is no load. The output voltage drop when a load is added is determined by the parasitic resistance ($R_{ds(on)}$ of the MOSFET switches and the ESR of the capacitors) and the charge transfer loss between capacitors. Details will be discussed in the following application information section.

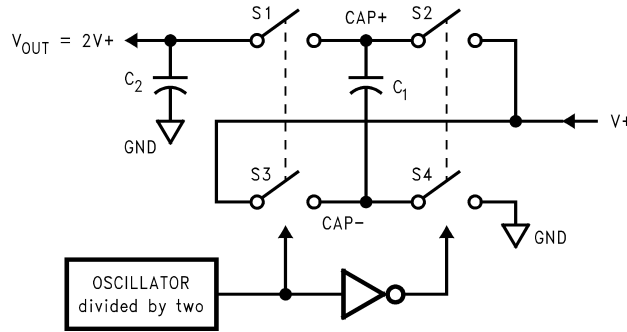

Figure 14. Voltage Doubling Principle

POSITIVE VOLTAGE DOUBLER

The main application of the LM2767 is to double the input voltage. The range of the input supply voltage is 1.8V to 5.5V.

The output characteristics of this circuit can be approximated by an ideal voltage source in series with a resistance. The voltage source equals $2V_+$. The output resistance R_{out} is a function of the ON resistance of the internal MOSFET switches, the oscillator frequency, and the capacitance and ESR of C_1 and C_2 . Since the switching current charging and discharging C_1 is approximately twice the output current, the effect of the ESR of the pumping capacitor C_1 will be multiplied by four in the output resistance. The output capacitor C_2 is charging and discharging at a current approximately equal to the output current, therefore, its ESR only counts once in the output resistance. A good approximation of R_{out} is:

$$R_{OUT} \cong 2R_{SW} + \frac{2}{f_{OSC} \times C_1} + 4ESR_{C1} + ESR_{C2} \quad (1)$$

where R_{SW} is the sum of the ON resistances of the internal MOSFET switches shown in Figure 14. R_{SW} is typically 4.5Ω for the LM2767.

The peak-to-peak output voltage ripple is determined by the oscillator frequency as well as the capacitance and ESR of the output capacitor C_2 :

$$V_{RIPPLE} = \frac{I_L}{f_{OSC} \times C_2} + 2 \times I_L \times ESR_{C2} \quad (2)$$

High capacitance, low ESR capacitors can reduce both the output resistance and the voltage ripple.

The Schottky diode D_1 is only needed to protect the device from turning-on its own parasitic diode and potentially latching-up. During start-up, D_1 will also quickly charge up the output capacitor to V_{IN} minus the diode drop thereby decreasing the start-up time. Therefore, the Schottky diode D_1 should have enough current carrying capability to charge the output capacitor at start-up, as well as a low forward voltage to prevent the internal parasitic diode from turning-on. A Schottky diode like 1N5817 can be used for most applications. If the input voltage ramp is less than 10V/ms, a smaller Schottky diode like MBR0520LT1 can be used to reduce the circuit size.

CAPACITOR SELECTION

As discussed in the *Positive Voltage Doubler* section, the output resistance and ripple voltage are dependent on the capacitance and ESR values of the external capacitors. The output voltage drop is the load current times the output resistance, and the power efficiency is

$$\eta = \frac{P_{OUT}}{P_{IN}} = \frac{I_L^2 R_L}{I_L^2 R_L + I_L^2 R_{OUT} + I_Q(V_+)} \quad (3)$$

Where $I_Q(V_+)$ is the quiescent power loss of the IC device, and $I_L^2 R_{out}$ is the conversion loss associated with the switch on-resistance, the two external capacitors and their ESRs.

The selection of capacitors is based on the allowable voltage droop (which equals $I_{out} R_{out}$), and the desired output voltage ripple. Low ESR capacitors (Table 1) are recommended to maximize efficiency, reduce the output voltage drop and voltage ripple.

Table 1. Low ESR Capacitor Manufacturers

Manufacturer	Phone	Website	Capacitor Type
Nichicon Corp.	(847)-843-7500	www.nichicon.com	PL & PF series, through-hole aluminum electrolytic
AVX Corp.	(843)-448-9411	www.avxcorp.com	TPS series, surface-mount tantalum
Sprague	(207)-324-4140	www.vishay.com	593D, 594D, 595D series, surface-mount tantalum
Sanyo	(619)-661-6835	www.sanyovideo.com	OS-CON series, through-hole aluminum electrolytic
Murata	(800)-831-9172	www.murata.com	Ceramic chip capacitors
Taiyo Yuden	(800)-348-2496	www.t-yuden.com	Ceramic chip capacitors
Tokin	(408)-432-8020	www.tokin.com	Ceramic chip capacitors

PARALLELING DEVICES

Any number of LM2767s can be paralleled to reduce the output resistance. Since there is no closed loop feedback, as found in regulated circuits, stable operation is assured. Each device must have its own pumping capacitor C_1 , while only one output capacitor C_{out} is needed as shown in Figure 15. The composite output resistance is:

$$R_{OUT} = \frac{R_{OUT} \text{ of each LM2767}}{\text{Number of Devices}} \quad (4)$$

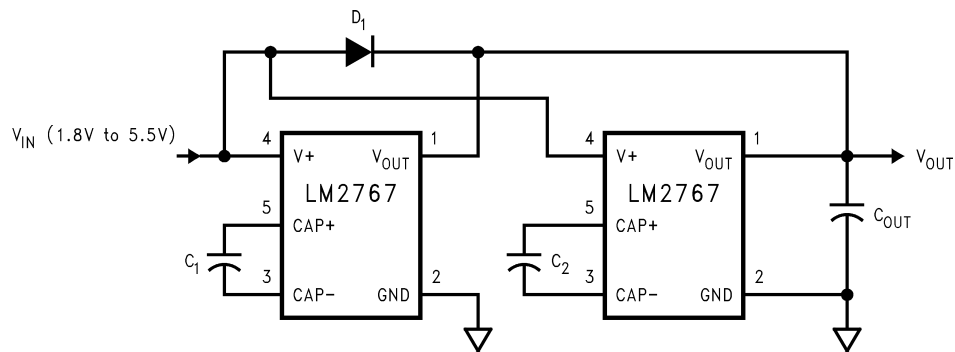

Figure 15. Lowering Output Resistance by Paralleling Devices

CASCADING DEVICES

Cascading the LM2767s is an easy way to produce a greater voltage (A two-stage cascade circuit is shown in Figure 16).

The effective output resistance is equal to the weighted sum of each individual device:

$$R_{out} = 1.5R_{out_1} + R_{out_2} \quad (5)$$

Note that increasing the number of cascading stages is practically limited since it significantly reduces the efficiency, increases the output resistance and output voltage ripple.

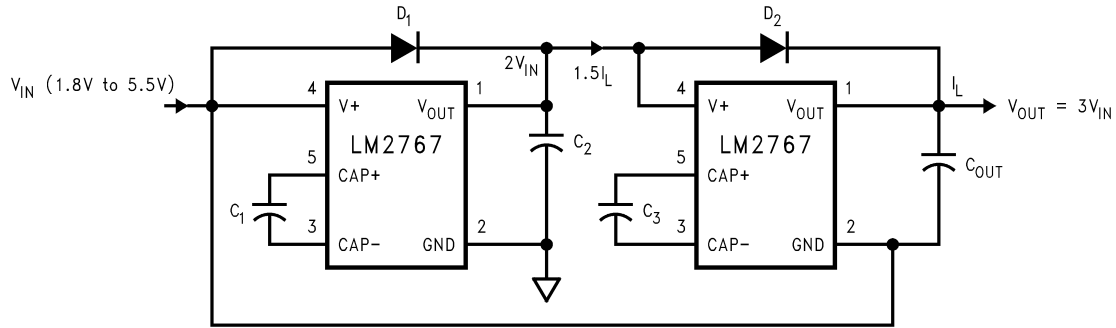

Figure 16. Increasing Output Voltage by Cascading Devices

REGULATING V_{OUT}

It is possible to regulate the output of the LM2767 by use of a low dropout regulator (such as LP2980-5.0). The whole converter is depicted in Figure 17.

A different output voltage is possible by use of LP2980-3.3, LP2980-3.0, or LP2980-adj.

Note that the following conditions must be satisfied simultaneously for worst case design:

$$2V_{in_min} > V_{out_min} + V_{drop_max} (LP2980) + I_{out_max} \times R_{out_max} (LM2767) \tag{6}$$

$$2V_{in_max} < V_{out_max} + V_{drop_min} (LP2980) + I_{out_min} \times R_{out_min} (LM2767) \tag{7}$$

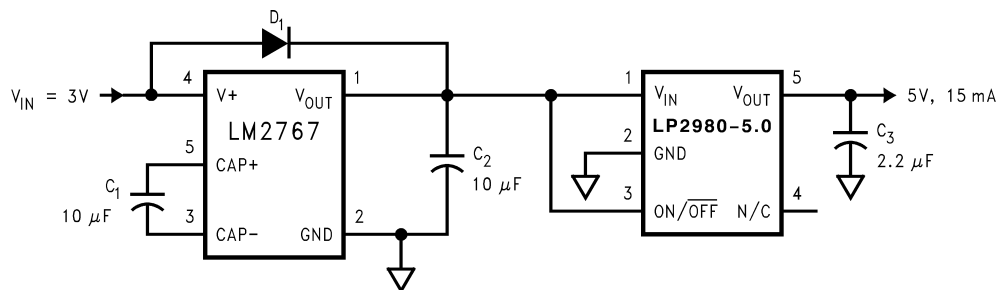



Figure 17. Generate a Regulated +5V from +3V Input Voltage

REVISION HISTORY

Changes from Revision B (May 2013) to Revision C	Page
<hr/> <ul style="list-style-type: none">• Changed layout of National Data Sheet to TI format	<hr/> 8

PACKAGING INFORMATION

Orderable Device	Status (1)	Package Type	Package Drawing	Pins	Package Qty	Eco Plan (2)	Lead/Ball Finish (6)	MSL Peak Temp (3)	Op Temp (°C)	Device Marking (4/5)	Samples
LM2767M5	NRND	SOT-23	DBV	5	1000	TBD	Call TI	Call TI	-40 to 85	S17B	
LM2767M5/NOPB	ACTIVE	SOT-23	DBV	5	1000	Green (RoHS & no Sb/Br)	CU SN	Level-1-260C-UNLIM	-40 to 85	S17B	
LM2767M5X	NRND	SOT-23	DBV	5	3000	TBD	Call TI	Call TI	-40 to 85	S17B	
LM2767M5X/NOPB	ACTIVE	SOT-23	DBV	5	3000	Green (RoHS & no Sb/Br)	CU SN	Level-1-260C-UNLIM	-40 to 85	S17B	

(1) The marketing status values are defined as follows:

ACTIVE: Product device recommended for new designs.

LIFEBUY: TI has announced that the device will be discontinued, and a lifetime-buy period is in effect.

NRND: Not recommended for new designs. Device is in production to support existing customers, but TI does not recommend using this part in a new design.

PREVIEW: Device has been announced but is not in production. Samples may or may not be available.

OBSELETE: TI has discontinued the production of the device.

(2) Eco Plan - The planned eco-friendly classification: Pb-Free (RoHS), Pb-Free (RoHS Exempt), or Green (RoHS & no Sb/Br) - please check <http://www.ti.com/productcontent> for the latest availability information and additional product content details.

TBD: The Pb-Free/Green conversion plan has not been defined.

Pb-Free (RoHS): TI's terms "Lead-Free" or "Pb-Free" mean semiconductor products that are compatible with the current RoHS requirements for all 6 substances, including the requirement that lead not exceed 0.1% by weight in homogeneous materials. Where designed to be soldered at high temperatures, TI Pb-Free products are suitable for use in specified lead-free processes.

Pb-Free (RoHS Exempt): This component has a RoHS exemption for either 1) lead-based flip-chip solder bumps used between the die and package, or 2) lead-based die adhesive used between the die and leadframe. The component is otherwise considered Pb-Free (RoHS compatible) as defined above.

Green (RoHS & no Sb/Br): TI defines "Green" to mean Pb-Free (RoHS compatible), and free of Bromine (Br) and Antimony (Sb) based flame retardants (Br or Sb do not exceed 0.1% by weight in homogeneous material)

(3) MSL, Peak Temp. - The Moisture Sensitivity Level rating according to the JEDEC industry standard classifications, and peak solder temperature.

(4) There may be additional marking, which relates to the logo, the lot trace code information, or the environmental category on the device.

(5) Multiple Device Markings will be inside parentheses. Only one Device Marking contained in parentheses and separated by a "~" will appear on a device. If a line is indented then it is a continuation of the previous line and the two combined represent the entire Device Marking for that device.

(6) Lead/Ball Finish - Orderable Devices may have multiple material finish options. Finish options are separated by a vertical ruled line. Lead/Ball Finish values may wrap to two lines if the finish value exceeds the maximum column width.

Important Information and Disclaimer:The information provided on this page represents TI's knowledge and belief as of the date that it is provided. TI bases its knowledge and belief on information provided by third parties, and makes no representation or warranty as to the accuracy of such information. Efforts are underway to better integrate information from third parties. TI has taken and

continues to take reasonable steps to provide representative and accurate information but may not have conducted destructive testing or chemical analysis on incoming materials and chemicals. TI and TI suppliers consider certain information to be proprietary, and thus CAS numbers and other limited information may not be available for release.

In no event shall TI's liability arising out of such information exceed the total purchase price of the TI part(s) at issue in this document sold by TI to Customer on an annual basis.

TAPE AND REEL INFORMATION

QUADRANT ASSIGNMENTS FOR PIN 1 ORIENTATION IN TAPE

*All dimensions are nominal

Device	Package Type	Package Drawing	Pins	SPQ	Reel Diameter (mm)	Reel Width W1 (mm)	A0 (mm)	B0 (mm)	K0 (mm)	P1 (mm)	W (mm)	Pin1 Quadrant
LM2767M5	SOT-23	DBV	5	1000	178.0	8.4	3.2	3.2	1.4	4.0	8.0	Q3
LM2767M5/NOPB	SOT-23	DBV	5	1000	178.0	8.4	3.2	3.2	1.4	4.0	8.0	Q3
LM2767M5X	SOT-23	DBV	5	3000	178.0	8.4	3.2	3.2	1.4	4.0	8.0	Q3
LM2767M5X/NOPB	SOT-23	DBV	5	3000	178.0	8.4	3.2	3.2	1.4	4.0	8.0	Q3

TAPE AND REEL BOX DIMENSIONS

*All dimensions are nominal

Device	Package Type	Package Drawing	Pins	SPQ	Length (mm)	Width (mm)	Height (mm)
LM2767M5	SOT-23	DBV	5	1000	210.0	185.0	35.0
LM2767M5/NOPB	SOT-23	DBV	5	1000	210.0	185.0	35.0
LM2767M5X	SOT-23	DBV	5	3000	210.0	185.0	35.0
LM2767M5X/NOPB	SOT-23	DBV	5	3000	210.0	185.0	35.0

DBV (R-PDSO-G5)

PLASTIC SMALL-OUTLINE PACKAGE



- NOTES:
- A. All linear dimensions are in millimeters.
 - B. This drawing is subject to change without notice.
 - C. Body dimensions do not include mold flash or protrusion. Mold flash and protrusion shall not exceed 0.15 per side.
 - D. Falls within JEDEC MO-178 Variation AA.

DBV (R-PDSO-G5)

PLASTIC SMALL OUTLINE



- NOTES:
- A. All linear dimensions are in millimeters.
 - B. This drawing is subject to change without notice.
 - C. Customers should place a note on the circuit board fabrication drawing not to alter the center solder mask defined pad.
 - D. Publication IPC-7351 is recommended for alternate designs.
 - E. Laser cutting apertures with trapezoidal walls and also rounding corners will offer better paste release. Customers should contact their board assembly site for stencil design recommendations. Example stencil design based on a 50% volumetric metal load solder paste. Refer to IPC-7525 for other stencil recommendations.

IMPORTANT NOTICE

Texas Instruments Incorporated and its subsidiaries (TI) reserve the right to make corrections, enhancements, improvements and other changes to its semiconductor products and services per JESD46, latest issue, and to discontinue any product or service per JESD48, latest issue. Buyers should obtain the latest relevant information before placing orders and should verify that such information is current and complete. All semiconductor products (also referred to herein as "components") are sold subject to TI's terms and conditions of sale supplied at the time of order acknowledgment.

TI warrants performance of its components to the specifications applicable at the time of sale, in accordance with the warranty in TI's terms and conditions of sale of semiconductor products. Testing and other quality control techniques are used to the extent TI deems necessary to support this warranty. Except where mandated by applicable law, testing of all parameters of each component is not necessarily performed.

TI assumes no liability for applications assistance or the design of Buyers' products. Buyers are responsible for their products and applications using TI components. To minimize the risks associated with Buyers' products and applications, Buyers should provide adequate design and operating safeguards.

TI does not warrant or represent that any license, either express or implied, is granted under any patent right, copyright, mask work right, or other intellectual property right relating to any combination, machine, or process in which TI components or services are used. Information published by TI regarding third-party products or services does not constitute a license to use such products or services or a warranty or endorsement thereof. Use of such information may require a license from a third party under the patents or other intellectual property of the third party, or a license from TI under the patents or other intellectual property of TI.

Reproduction of significant portions of TI information in TI data books or data sheets is permissible only if reproduction is without alteration and is accompanied by all associated warranties, conditions, limitations, and notices. TI is not responsible or liable for such altered documentation. Information of third parties may be subject to additional restrictions.

Resale of TI components or services with statements different from or beyond the parameters stated by TI for that component or service voids all express and any implied warranties for the associated TI component or service and is an unfair and deceptive business practice. TI is not responsible or liable for any such statements.

Buyer acknowledges and agrees that it is solely responsible for compliance with all legal, regulatory and safety-related requirements concerning its products, and any use of TI components in its applications, notwithstanding any applications-related information or support that may be provided by TI. Buyer represents and agrees that it has all the necessary expertise to create and implement safeguards which anticipate dangerous consequences of failures, monitor failures and their consequences, lessen the likelihood of failures that might cause harm and take appropriate remedial actions. Buyer will fully indemnify TI and its representatives against any damages arising out of the use of any TI components in safety-critical applications.

In some cases, TI components may be promoted specifically to facilitate safety-related applications. With such components, TI's goal is to help enable customers to design and create their own end-product solutions that meet applicable functional safety standards and requirements. Nonetheless, such components are subject to these terms.

No TI components are authorized for use in FDA Class III (or similar life-critical medical equipment) unless authorized officers of the parties have executed a special agreement specifically governing such use.

Only those TI components which TI has specifically designated as military grade or "enhanced plastic" are designed and intended for use in military/aerospace applications or environments. Buyer acknowledges and agrees that any military or aerospace use of TI components which have **not** been so designated is solely at the Buyer's risk, and that Buyer is solely responsible for compliance with all legal and regulatory requirements in connection with such use.

TI has specifically designated certain components as meeting ISO/TS16949 requirements, mainly for automotive use. In any case of use of non-designated products, TI will not be responsible for any failure to meet ISO/TS16949.

Products

Audio	www.ti.com/audio
Amplifiers	amplifier.ti.com
Data Converters	dataconverter.ti.com
DLP® Products	www.dlp.com
DSP	dsp.ti.com
Clocks and Timers	www.ti.com/clocks
Interface	interface.ti.com
Logic	logic.ti.com
Power Mgmt	power.ti.com
Microcontrollers	microcontroller.ti.com
RFID	www.ti-rfid.com
OMAP Applications Processors	www.ti.com/omap
Wireless Connectivity	www.ti.com/wirelessconnectivity

Applications

Automotive and Transportation	www.ti.com/automotive
Communications and Telecom	www.ti.com/communications
Computers and Peripherals	www.ti.com/computers
Consumer Electronics	www.ti.com/consumer-apps
Energy and Lighting	www.ti.com/energy
Industrial	www.ti.com/industrial
Medical	www.ti.com/medical
Security	www.ti.com/security
Space, Avionics and Defense	www.ti.com/space-avionics-defense
Video and Imaging	www.ti.com/video

TI E2E Community

e2e.ti.com