

Impact driver 1/2" CSP 580

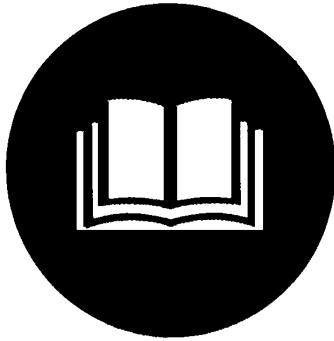

English



1/2" adaptor

With direction reversal pin for
clockwise/anticlockwise rotation







Item no.: 2010188

Please read these operating instructions carefully before using the device.





EN	Complaints and orders for replacement parts are processed quickly and efficiently. Please contact us using the information below.		
	Tel.: +49 6182 / 99387-0	Fax: +49 6182 / 99387-20	Email: info@aerotec.info

Labelling:



Product safety – prohibition signs:

			
Complies with EU standards	Prohibition sign	No loose clothing!	No jewellery, etc.

Warning – mandatory action signs:

			
CAUTION/WARNING	Observe operating instructions	Wear hearing protection	Wear eye protection

Environmental protection:

		
Dispose of properly	Cardboard packaging material can be recycled at designated collection points.	Electrical or electronic devices that are faulty or are ready for disposal must be recycled at designated collection points.

EC declaration of conformity

We the supplier,
 proBAUES GmbH
 Ferdinand Porsche Straße 16
 63503 Seligenstadt
 Germany

hereby declare that the following designated devices, based on their design and type as well as the versions placed on the market by us, meet the relevant fundamental health and safety requirements set out in the EU Directives.

Any modification to the devices not approved by us invalidates this declaration of conformity.

Device designation:
 hp patcher 1/2" MNCSP330, item no.: 2010118

Date/Signature of manufacturer: 22/10/2012



Information on the signatory: Mr Markert, Managing Director

Relevant EU Directives
 2006/42/EC

Applicable harmonised standards
 EN ISO 12100:2010 and EN ISO 11146:2010

Device:

Impact driver 1/2" CSP 580

Technical data:

Impact driver 1/2" CSP 580

Operating pressure:	6.3 bar
Air consumption:	120 l/min
Threaded connection:	1/4" internal
Drive:	1/2" square
Max. torque:	580 Nm
Idle speed:	9000 rpm
Rec. hose diameter:	10 mm
Sound power level:	98 dB (A)
Weight:	1.3 kg

Item no. 2010118

Included in delivery:

- 1 x impact driver 1/2" CSP 580
- 1 x SK nipple 1/4" external
- 1 x operating instructions

General safety instructions:



Safety note! Failure to comply with the following instructions may lead to injuries.

Read all instructions very carefully before using the air tool. All users must be fully aware and sufficiently informed of the safety requirements when using pneumatic tools. Any servicing or repair work must only be

performed by trained specialists.

Only impact sockets should be used with impact drivers.

Never use impact sockets with a worn or damaged square drive. Ensure before every use that the square drive on the impact sockets and extension or spindle of the impact driver are not worn.

Always ensure that the work surface and working position of the tool are stable and secure before using the tool.

Ensure before every use that the torque setting is correct. An incorrect setting may cause the screws to break off and cause the tool to move uncontrollably.

Ensure before use that the direction reversal pin is in the correct position for clockwise or anticlockwise rotation.

Regularly inspect the pneumatic hose and all connections for wear or damage.

Always carry the tool by its handle and not by the hose.

Never exceed the recommended maximum operating pressure (6.3 bar).

The tool is not earthed or electrically insulated. Never use the tool where there is a risk of contact with electricity.

We recommend disconnecting the air supply when changing the impact sockets. The trigger switch must not be operated during this process.

Ensure that there is sufficient room behind the tool when loosening screws, so that your hand does not get stuck.

If the tool exhibits signs of irregular function and performance during use, stop using it immediately and have the device

serviced or repaired.

Do not use unnecessarily long pressure hoses in order to prevent tripping hazards.

Read the operating instructions for the compressor and follow the safety instructions for using the compressor.

ALWAYS wear certified eye protection and hearing protection.

Take off watches, rings and other items that may interfere with safe operation. Loose clothing or jewellery may get caught in the air compressor or in the air tool and lead to injuries.

The trigger switch must not be operated when the device is connected to the air supply.

Disconnect the device from the air supply when it is not in use. NEVER change accessories or carry out ANY maintenance work as long as the device is connected to the air supply.

Carry out proper maintenance on the device and follow all instructions for lubrication and tool maintenance.

Do not carry the device by the hose or rip the hose from the air supply, as this may damage the hose and connection parts. Do not allow the hose to come into contact with heat or sharp edges. The hose should be replaced if it is damaged or worn.

NEVER operate the device with an air pressure exceeding 6.3 bar. Use a pressure controller that reduces the air pressure to 6.3 bar.

ALWAYS operate the device a safe distance away from other people or animals.

Before starting:

Air supply

Lubricate the device before using it (see final page of this document). We recommend using an oil-fog lubricator.

Assembly

Always disconnect the air supply hose before inserting or removing impact sockets or attachments.



Safety note!

Wear eye protection! Wear hearing protection!

Ensure that only compressed air that is condensate-free is used for operation. It is sufficient to connect a filter water separator upstream.

Next, start the air compressor. The maximum operating air pressure for the tool is 6.3 bar. The operating pressure can be set on your compressor using a pressure controller. The output (torque) of impact drivers under prime working conditions is mainly determined by two factors:

- a) the operating pressure used
- b) the duration of the work carried out on the screw connection. The normal duration of work on a screw connection is 3–5 seconds on average.

- 2. Place 4–6 drops of air tool oil or another suitable oil in the air inlet while the trigger switch is pressed.
- 3. Then reconnect the tool to the air supply and let it run for approximately 30 seconds in order to eliminate any superfluous oil.

This lubrication process helps reduce moisture, dust and dirt that accumulates over time in any air tool and affects its performance.

Every 4 months, or if the impact driver is not used very often, the air hose should be removed and a larger amount of air tool oil should be poured into the air inlet. Then reconnect the air hose and let the impact driver run for approximately 20 seconds in order to clean the air tool's motor. After cleaning, follow the instructions for lubrication.

Maintenance and care

Lubrication

- 1. Disconnect the impact driver from the air supply.

Troubleshooting

Problem	Possible cause	Solution
The impact driver is not working or is only running slowly	Insufficient air pressure, hose diameter is too small	Check the air pressure at the inlet. It must be at least 6.3 bar.
	Air pressure is set too low	Increase the pressure to 6.3 bar.
	Impact driver needs to be lubricated	See maintenance instructions.
	Impact driver needs to be cleaned	See maintenance instructions.
	Air hose is not leak-tight	Check all hose fittings.

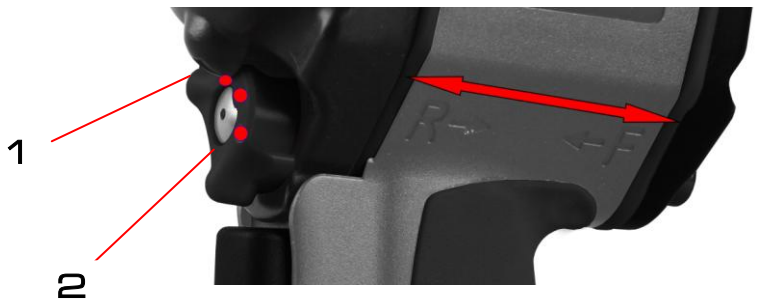

- 1. Direction reversal pin/rotational direction: (Push the pin to [F] for clockwise or [R] for anticlockwise rotation.)
- 2. Torque setting: choose between 3 levels (see red markings; torque can only be set for clockwise rotation [F], as in anticlockwise operation.)

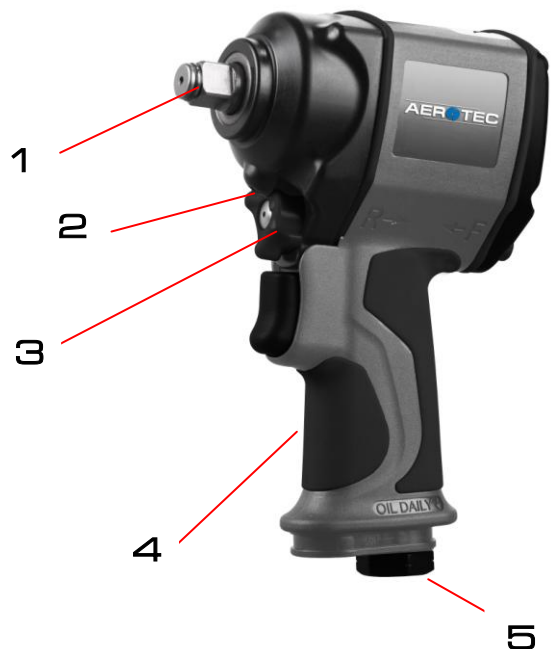

- 1. Socket adaptor, square 1/2"
- 2. Direction reversal pin
- 3. Torque controller
- 4. trigger switch
- 5. Connection for pneumatic hose (Universal connection is included in delivery.)

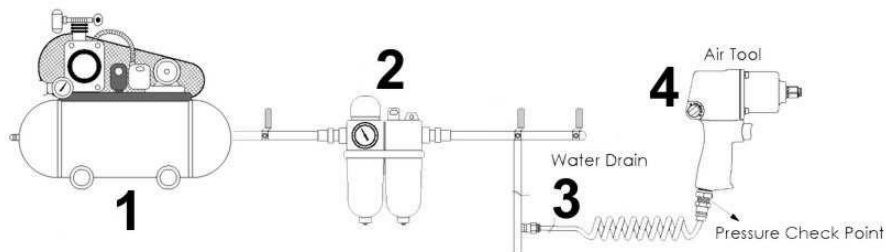

Recommended for use:

1. Compressor
2. Filter unit with fog-oil lubricator
3. Stop cock
4. Air tool

Warranty:

We offer a **24-month warranty** for this product on the basis of single-shift operation, starting from the date of purchase. Under the warranty, any parts verified to be faulty due to production errors or material defects will be replaced or repaired as we see fit, free of charge.

The warranty period begins from the point of delivery of the product to the customer. Further claims, particular those for compensation for damages, are excluded. Aerotec explicitly does not accept liability for subsequent damages.

Attention! Faults caused by failure to observe the operating instructions, improper use, unauthorised modifications by the customer or third parties, or by uncontrollable circumstances are not included in the warranty.

The warranty period is not extended or reset when parts are replaced or

repaired.

Warranty claims are executed exclusively by Aerotec and handled by your retailer.

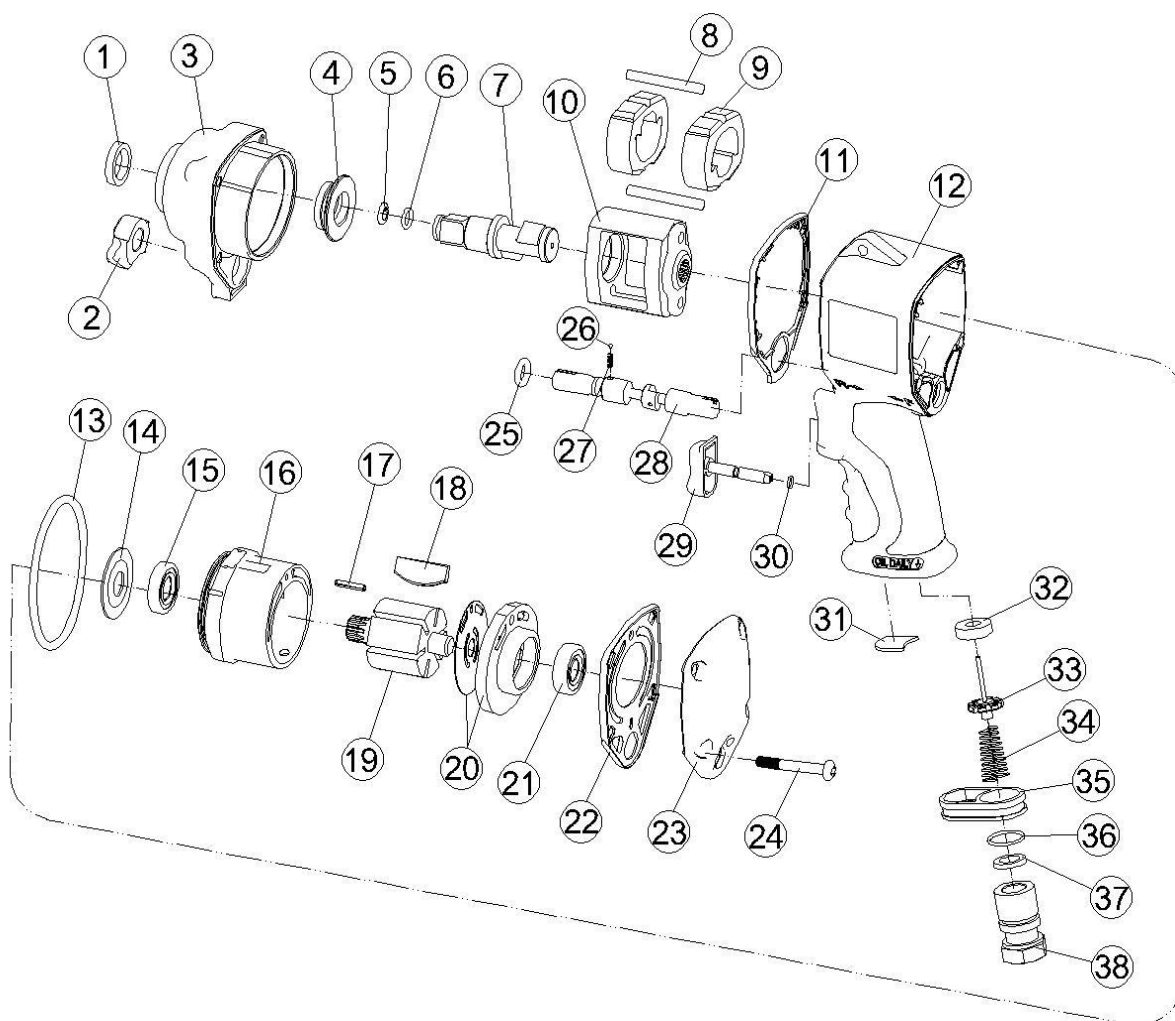

Part number	Name	Qty	Part number	Name	Qty
0985TA01	Oil seal	1	0985TA23	Rear cover	1
0985TA02	Reversing lever	1	0985TA24	Screw	4
0985TA03	Hammer housing	1	0985TA25	O-ring	1
0985TA04	Socket	1	0985TA26	Steel ball	1
0985TA05	Anvil collar	1	0985TA27	Spring	1
0985TA06	O-ring	1	0985TA28	Reversing valve	1
0985TA07	Anvil (1/2" D)	1	0985TA29	Trigger switch	1
0985TA08	Hammer pin	2	0985TA30	O-ring	1
0985TA09	Hammer	2	0985TA31	Sound dampener	1
0985TA10	Hammer frame assembly	1	0985TA32	Valve holder	1
0985TA11	Front seal	1	0985TA33	Valve stem	1
0985TA12	Motor housing	1	0985TA34	Spring	1
0985TA13	O-ring	1	0985TA35	Exhaust deflector	1
0985TA14	Seal	1	0985TA36	O-ring	1
0985TA15	Ball bearing	1	0985TA37	Seal	1
0985TA16	Cylinder	1	0985TA38A	Hose adaptor -18NPT	1
0985TA17	Spring pin	1	0985TA38B	Hose adaptor -19PT	
0985TA18	Rotor blade	6	0985TA38C	Hose adaptor -19PF(BSP)	
0985TA19	Rotor	1			
0985TA20	Rear plate	1			
0985TA21	Ball bearing	1			
0985TA22	Rear seal	1			