

**Φ22 mm, Buzzer, Black body, 12 V AC/DC,**  
Item no. 93032C3

Version 08/14

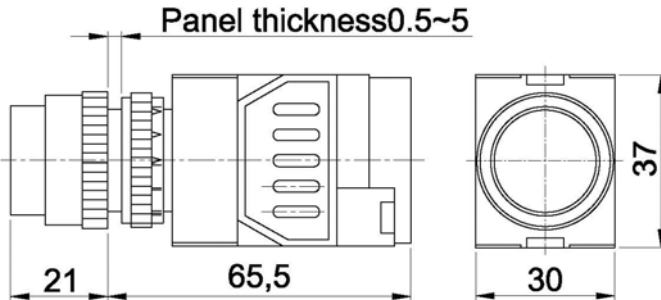

Specification .....	Y090E-M/12V
Mounting diameter .....	22 mm
Buzzer current (max.) .....	≤20 mA
Buzzer voltage .....	12V AC/DC
Terminal type .....	screw terminal
Dielectric intensity .....	1000 V/AC
Operating and storage temperature .....	-25 to +55 °C
Operating and storage humidity .....	45 to 85 % RH
Panel thickness .....	0.5 ~ 5 mm
Sound intensity .....	≥75 dB (1m)
Cap material .....	PC
Body material .....	ABS