

BLE232

Manual

BLE232: Manual

Copyright © 2014 taskit GmbH

All rights to this documentation and to the product(s) described herein are reserved by taskit GmbH.

This document was written with care, but errors cannot be excluded. Neither the company named above nor the seller assumes legal liability for mistakes, resulting operational errors or the consequences thereof. Trademarks, company names and product names may be protected by law. This document may not be reproduced, edited, copied or distributed in part or in whole without written permission.

This document was generated on 2014-01-28T09:17:23+01:00.

Table of Contents

1. Overview	1
1.1. BLE232 overview	1
2. Features	2
3. Hardware description	3
3.1. Technical characteristics	3
3.2. Serial interface and power supply schematics	3
3.3. BLE232 printed circuit board	4
4. Register description	5
4.1. Peripheral characteristic description	5
4.2. BLE232 configuration via serial port	6
5. Dimensions	8
5.1. BLE232 board and housing dimensions	8
6. Technical data	9
6.1. Technical data	9
6.2. Assignment of the serial interface	9

List of Figures

3.1. Serial interface and power supply schematics	3
3.2. BLE232 printed circuit board	4
4.1. BLE232 configuration via serial port	6
4.2. BLE232 configuration main menu	6
4.3. BLE232 configuration menu structure	7
5.1. BLE232 board and housing dimensions	8

List of Tables

3.1. BLE232 technical characteristics	3
4.1. BLE232 peripheral characteristic description	5
6.1. BLE232 technical data	9
6.2. BLE232 assignment of the serial interface	9

1. Overview

1.1. BLE232 overview

The BLE232 is an interface adapter converting RS232 communication to Bluetooth 4.0. It has been designed to transfer state messages. It is not especially suitable to transfer streams or large files, although it works for small files or less volume streams.

It is available as Bluetooth central or peripheral device. It can be used to connect to any other Bluetooth device such as a smartphone or a Bluetooth sensor that supports Bluetooth 4.0 or two can wirelessly bridge two RS232 ports. It can be used with Windows or Linux operating systems or directly with microcontrollers.

The BLE232 is available as couple for ready-to-use as BLE232-Central or BLE-Peripheral, otherwise the modules need to be paired.

The BLE232 has a programming and configuration interface. The configuration can be done via the Bluetooth characteristics settings of your operating system or directly via the serial interface (BLE232-peripheral) or only via the serial interface (BLE232-central)

If necessary and desired the module's microcontroller may be programmed by the user directly.

2. Features

- RS232 interface
- Bluetooth 4.0 central or peripheral connectivity
- Powered via serial port or externally
- Configuration via serial port
- Wireless serial bridging
- Connects serial port to smartphones, sensors and other Bluetooth devices that supports Bluetooth 4.0
- Programming interface

3. Hardware description

3.1. Technical characteristics

Device characteristic	Value
RS232 lines	RX, TX
RS232 baudrates	9600, 19200, 38400, 57600, 115200
RS232 data bits	8
RS232 parity	None, Even, Odd
RS232 stop bit	0, 1
RS232 flow Control	XON/XOFF
RS232 buffer	512 Bytes
Bluetooth mode	Central, Peripheral
Bluetooth range	20m - 50m
Bluetooth max transfer rate	8 kB/s
Current consumption	10 mA

Table 3.1. BLE232 technical characteristics

3.2. Serial interface and power supply schematics

The BLE232 can be powered internally via the serial line. The signals DCD, DSR, RST, CTS, DTR and RI can be used as power supply.

The BLE232 can as well be powered by an external power source between 3 to 16 Volt.

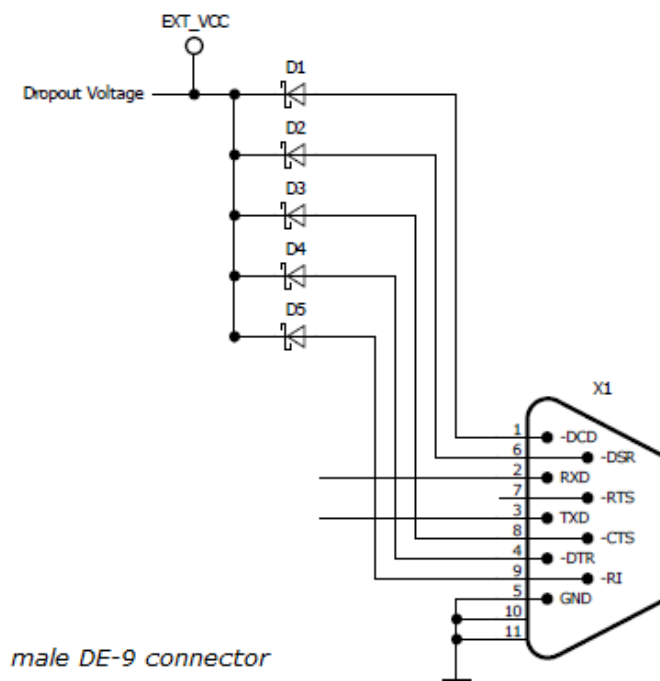

Figure 3.1. Serial interface and power supply schematics

3.3. BLE232 printed circuit board

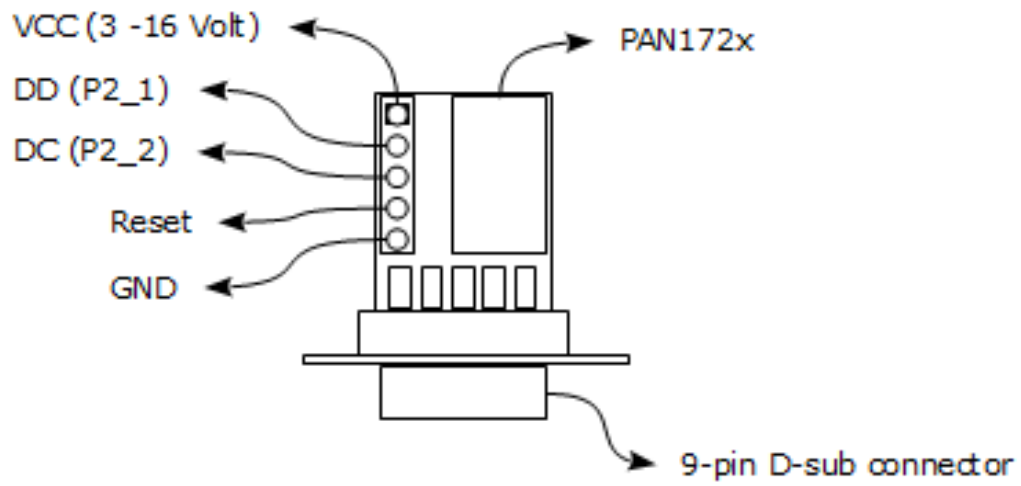

Figure 3.2. BLE232 printed circuit board

4. Register description

4.1. Peripheral characteristic description

Description	Data type	Units	Default	Permissions	Size
128Bit UUID: 912ffff0—3d4b-11e3-a760-0002a5d5c51b					
BLE232 service UUID					
128Bit UUID: 912ffff1—3d4b-11e3-a760-0002a5d5c51b					
Serial port interface	unit8			Write, Notify	
128Bit UUID: 912ffff2—3d4b-11e3-a760-0002a5d5c51b					
Serial port Config	unit8		0x04	Read, Write	1 Byte
	Bit0-Bit2	0: 9600			
		1: 19200			
		2: 38400			
		3: 57600			
		4: 115200			
	Bit3	0: OFF			
		1: ON			
	Bit4-Bit5	0: NO			
		1: EVEN			
		2: ODD			
	Bit6	0: ONE			
		1: TWO			
128Bit UUID: 912ffff3—3d4b-11e3-a760-0002a5d5c51b					
Note	String			Read, Write	20 Bytes
128Bit UUID: 912ffff4—3d4b-11e3-a760-0002a5d5c51b					
Device name	String		BLE232	Read, Write	20 Bytes

Table 4.1. BLE232 peripheral characteristic description

4.2. BLE232 configuration via serial port

Open a serial console program to change the settings of the BLE232 module. After power up, you have a certain time to go into the setting menu (default: 500ms). At this time should you go into the setting menu with three plus signs (+++).



Figure 4.1. BLE232 configuration via serial port

Press any key to continue. Navigate through the menu using the number keys. In this menu you can change settings of the serial port, Bluetooth low energy, idle timeout and debug report. The changes are stored in the device's internal flash memory.

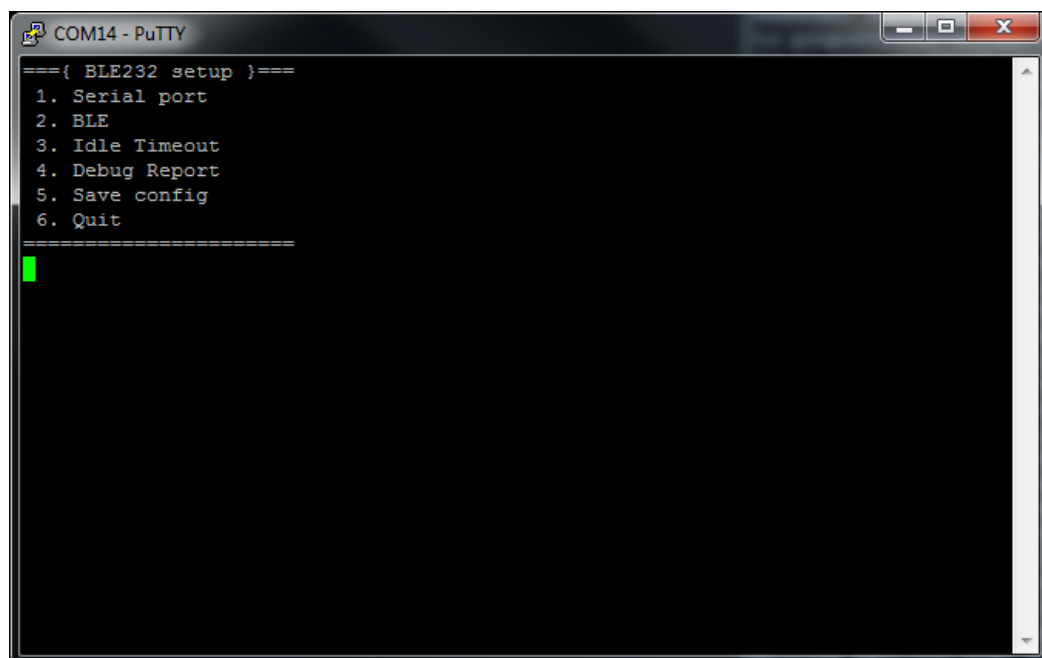

Figure 4.2. BLE232 configuration main menu

Here you can see the structure of the menus.

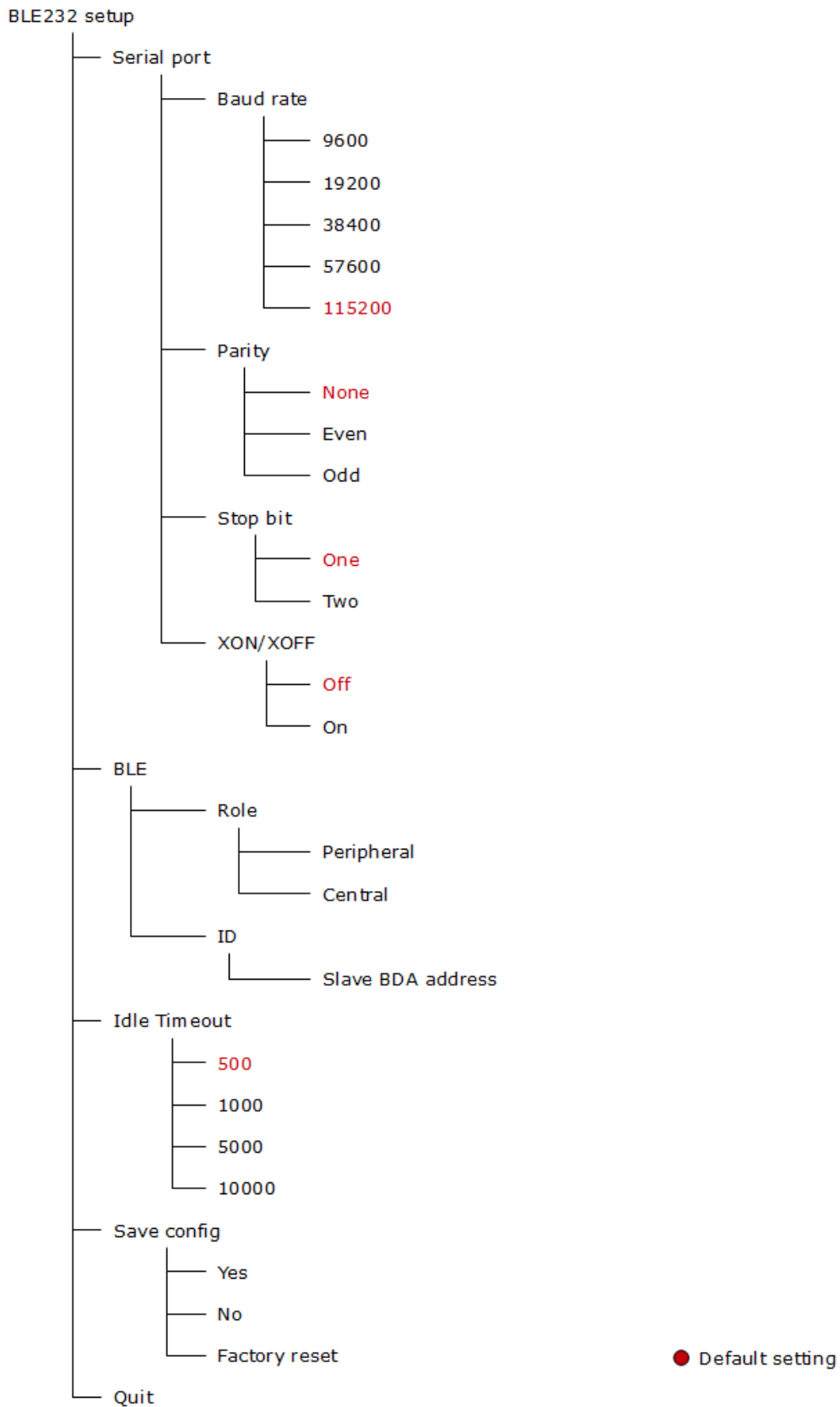

Figure 4.3. BLE232 configuration menu structure

5. Dimensions

5.1. BLE232 board and housing dimensions

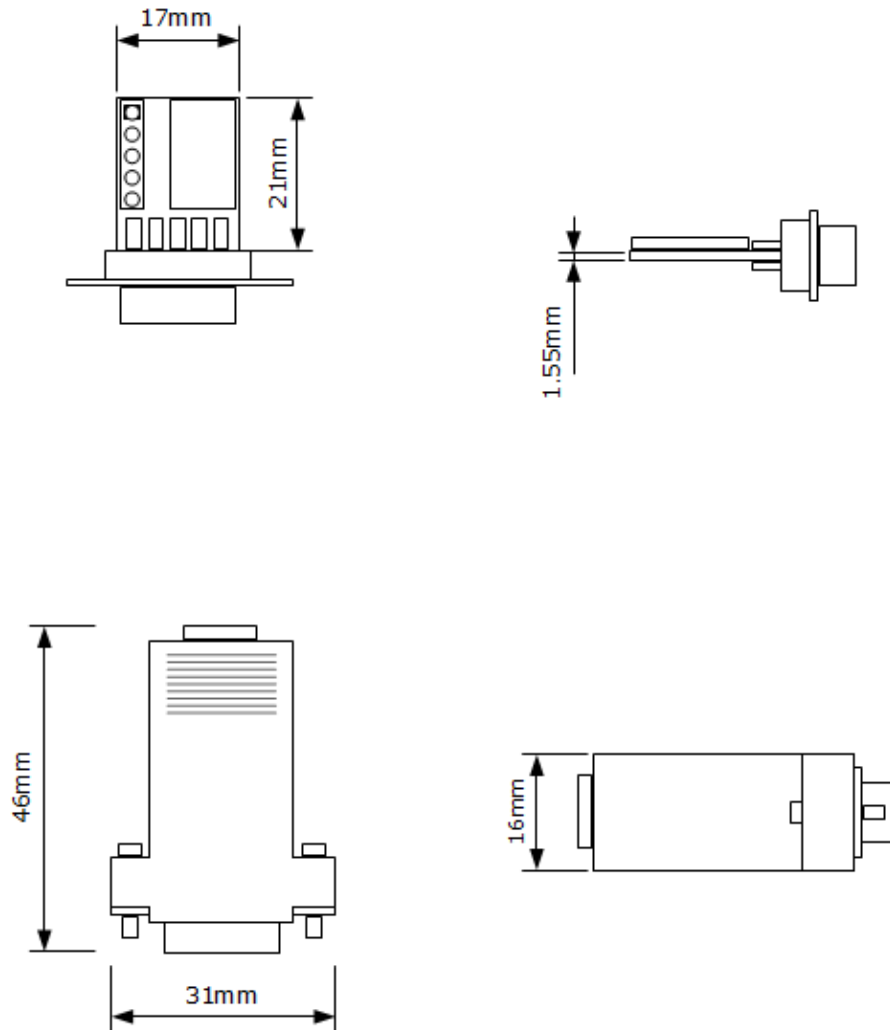

Figure 5.1. BLE232 board and housing dimensions

6. Technical data

6.1. Technical data

Radio transmission	
Operation frequency range	2402 - 2480 MHz
Channel spacing	2 MHz
Output power	0 dBm
Modulation	GFSK, MSK
Connections	
RS232	9-pin D-sub connector, male or female
Antenna	Chip-Antenna
Power supply voltage range	3 to 16 Volt
Internal power source	Via the serial line
External power source	On board
Bluetooth	
Version	4, Bluetooth low energy
Protocols	Bluetooth low energy protocol stack
Bluetooth profile	Generic Access, Service Discovery
Role	Peripheral, Central
Dimensions	
Circuit board	17x21x1.55mm
Housing	ca. 25x41x16mm

Table 6.1. BLE232 technical data

6.2. Assignment of the serial interface

Abbreviation	Pin Nr.	Direction male	Direction female
TxD	3	Output	Input
RxD	2	Input	Output
RTS	7	Power	Power
CTS	8	Power	Power
DSR	6	Power	Power
GND	5	-	-
DCD	1	Power	Power
DTR	4	Power	Power
RI	9	Power	Power

Table 6.2. BLE232 assignment of the serial interface