

More from Haynes Publishing . . .

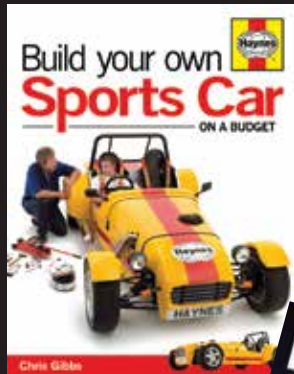
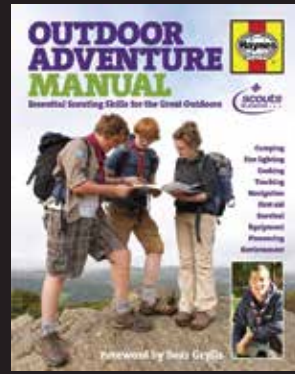
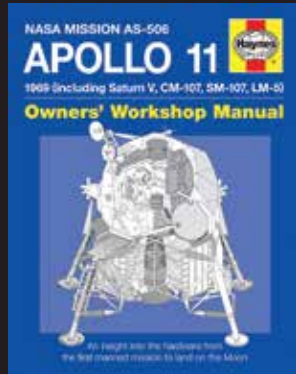

HM04R Haynes Build Your Own Internal Combustion Engine

Distributed by:

Trends UK Ltd
Harwell Innovation Centre,
Curie Avenue,
Harwell Oxford
Didcot,
OX11 0QG. UK



Customer Services:
+44 (0) 1702 208175

If at any time in the future you should need to dispose of this product please note that Waste Electrical products should not be disposed of with household waste. Please recycle where facilities exist. Check with your Local Authority or retailer for recycling advice. (Waste Electrical and Electronic Equipment Directive, WEEE)



Printed in China.



Haynes Publishing
Sparkford, Yeovil, Somerset
BA22 7JJ England

www.haynes.co.uk

Age range 10 +

**BUILD YOUR OWN
INTERNAL
COMBUSTION
ENGINE
HAYNES ASSEMBLY
MANUAL**



A working model of a car engine

Includes an explanation of how a 4-stroke engine works

**HM04R Haynes Build Your Own
Internal Combustion Engine Kit**

© Haynes Publishing 2015

All rights reserved. No part of this publication may be reproduced, stored in a retrieval system or transmitted, in any form or by any means, electronic, mechanical, photocopying, recording or otherwise, without prior permission in writing from the publisher.

First published in 2007

Published by Haynes Publishing

Printed in China

Please retain the information in this manual for future reference.



BUILD YOUR OWN

INTERNAL COMBUSTION ENGINE

Contents

What's this kit all about?	2
Before assembling your engine	3
Parts list	4
Assembling your engine	10
How a petrol engine works	31
Keeping a car and its engine healthy	37
Reducing pollution and saving on fuel bills	37
Basic engine terms	38

WHAT'S THIS KIT ALL ABOUT?

The engine you're about to start building is a greatly simplified version of a real car engine. The model is designed to be fun to put together, and to make it easier for you to understand how a full-size four-stroke car engine works. To keep things simple, the following components which are fitted to a full-size engine don't appear on the model: oil filter, cooling system, air filter, connecting rod bearings, piston rings, oil pump, alternator and starter (a drive module, powered by a small electric motor, is fitted in place of the starter motor.)

Also, the following components are included on the model, but don't function as they would on a full-size engine: water pump, throttle body, dipstick (without oil), flywheel and clutch.

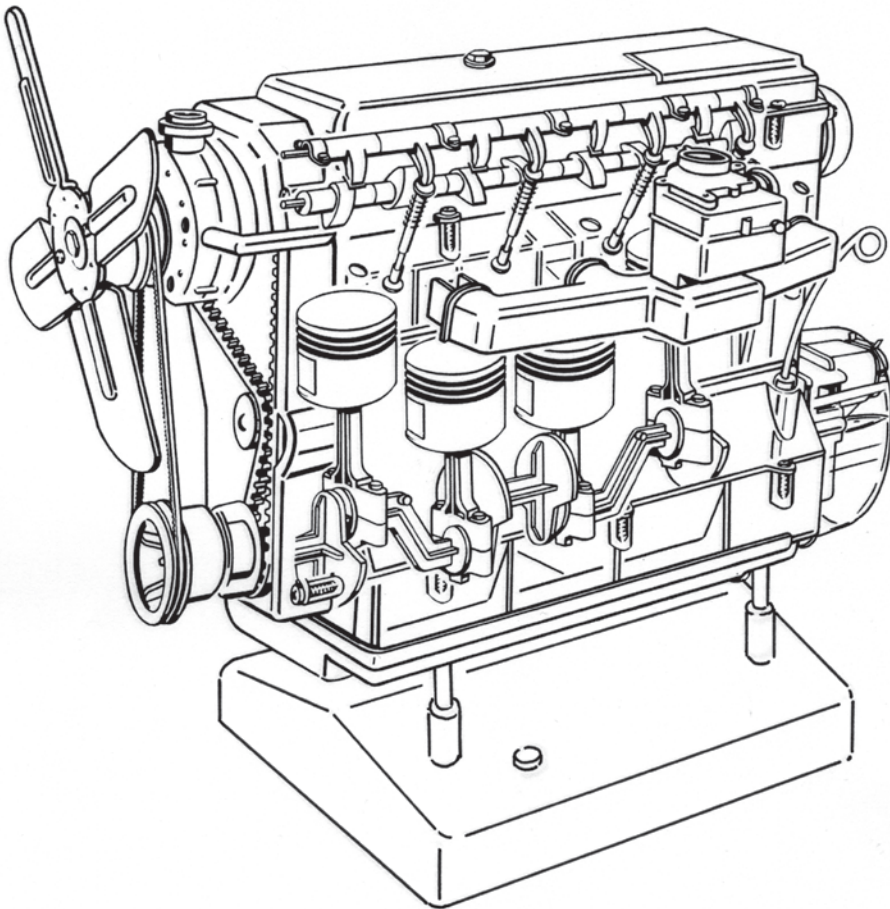

BEFORE ASSEMBLING YOUR ENGINE

Adults! Please ensure all instructions in this manual are read, followed, and retained for future reference.

Use under adult supervision.

Caution! For children over 10 years of age only.

Warning! Parts cut off from frames may contain sharp points.

Warning! Keep fingers well away from moving parts.

1 First, identify the various parts. Learn their names by looking at the illustrations in this Manual.

2 Only remove the parts from the plastic frames as you need them. You'll find illustrations helpful whenever you need to identify a part.

3 Carefully remove any burrs using a modelling knife or a small file. If you leave the burrs in place, they might stop the engine from working properly.

4 Use the screwdriver included with the kit to fit and tighten the screws that hold the model together. Take care not to over-tighten the screws.

5 Look at the illustrations and think carefully about how each part fits before fitting it permanently – take care not to fit a part upside-down or backwards.

6 The bearings in your engine should be lightly oiled, just as they would be in a full-size engine. Use a very light coating of vegetable oil, which you should be able to find in your kitchen. Don't use car engine oil!

If you follow the instructions carefully, and take your time putting the model together, your engine should work correctly. You'll have earned your Haynes Engineer Certificate, which you can download and print your certificate from www.haynes.co.uk/engine.

Qty.	Part	Part No.	Qty.	Part	Part No.
4	gudgeon pins	1	1	water pump rear half	32
4	connecting rods	2	1	water pump front half	33
8	piston halves	3	1	fan pulley	34
1	crankshaft	4	1	fan	35
4	connecting rod (big-end) bearing caps	5	1	crankshaft pulley	36
1	sump pan	6	1	flywheel	37
1	cylinder-head plate	6a	1	clutch cover	38
1	cylinder-head plate	6b	1	throttle body	
1	lower crankcase	7	1	inlet manifold	40
1	cylinder block	9	1	exhaust manifold	42
1	cylinder head gasket	10	1	dipstick	43
1	lower cylinder head	11	8	cams	A to H
8	valve stems	12	2	washers	
4	exhaust valve heads	13	1	rocker shaft, 3mm diameter, 156mm long	
4	inlet valve heads	14	1	camshaft, 3mm diameter (with flat along length), 3mm diameter, 206mm long	
1	upper cylinder head	23	1	timing belt	
8	rocker arms	24	8	1 fan belt	
5	rocker shaft bearing caps	25	1	8 valve springs	
1	rocker cover	26	1	distributor with leads and spark plugs	
1	crankshaft sprocket	27	1	electric motor unit	
1	camshaft sprocket	28	1	base	
1	timing alignment tool	29	67	screws	
1	timing belt idler pulley	30	1	screwdriver	
1	timing belt cover	31			

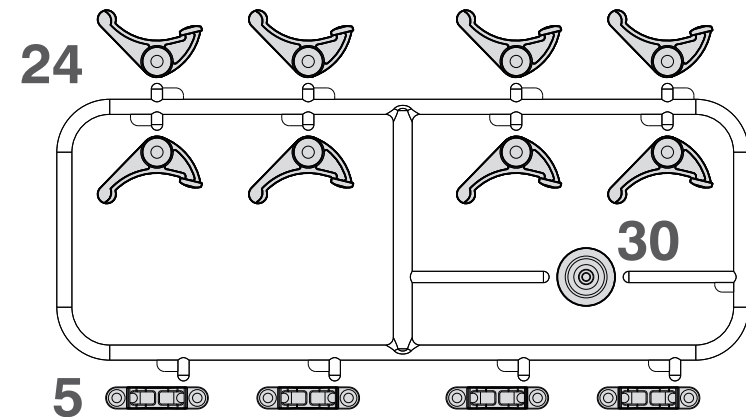
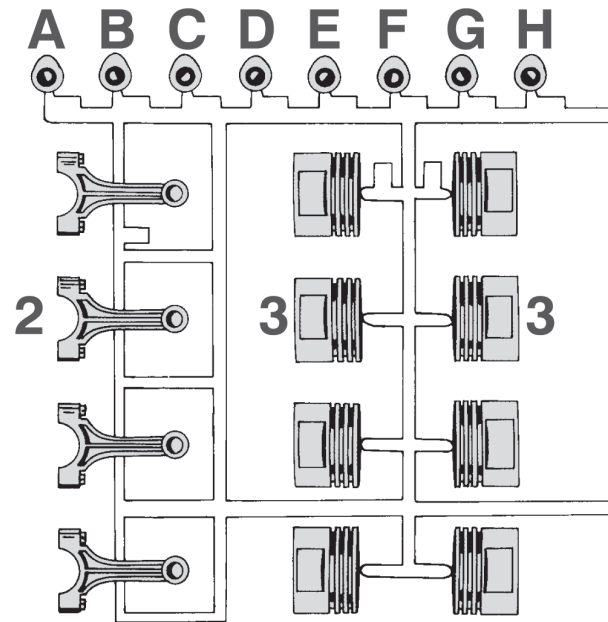

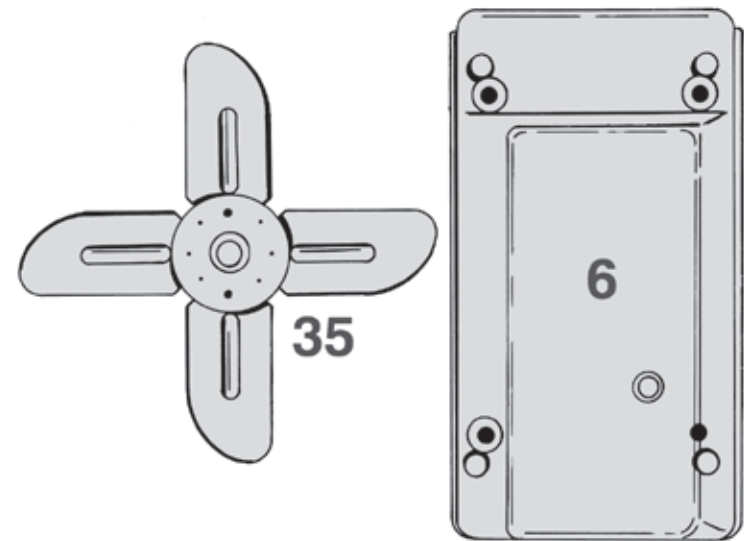
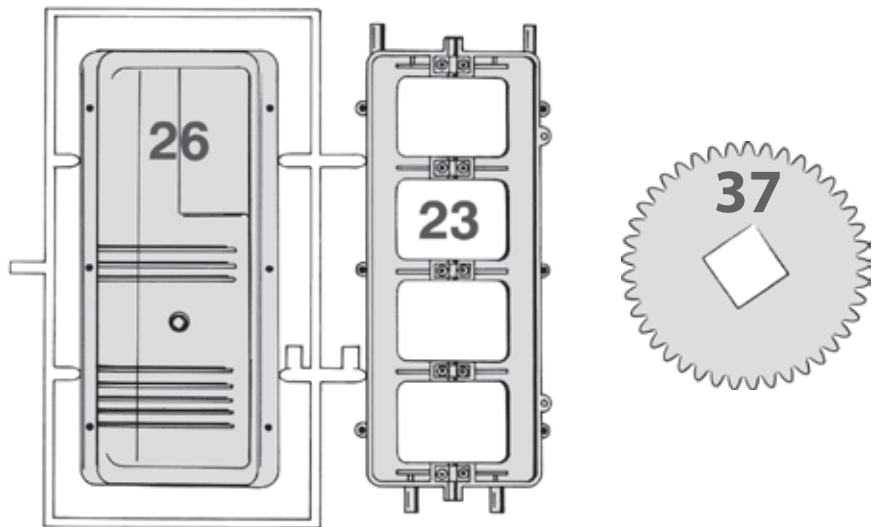
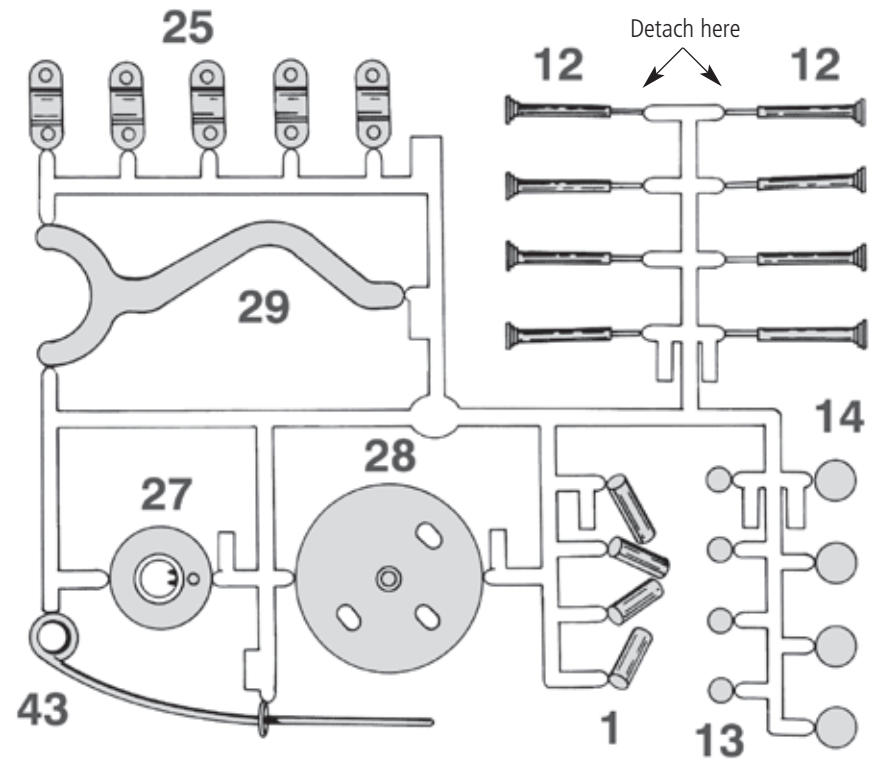
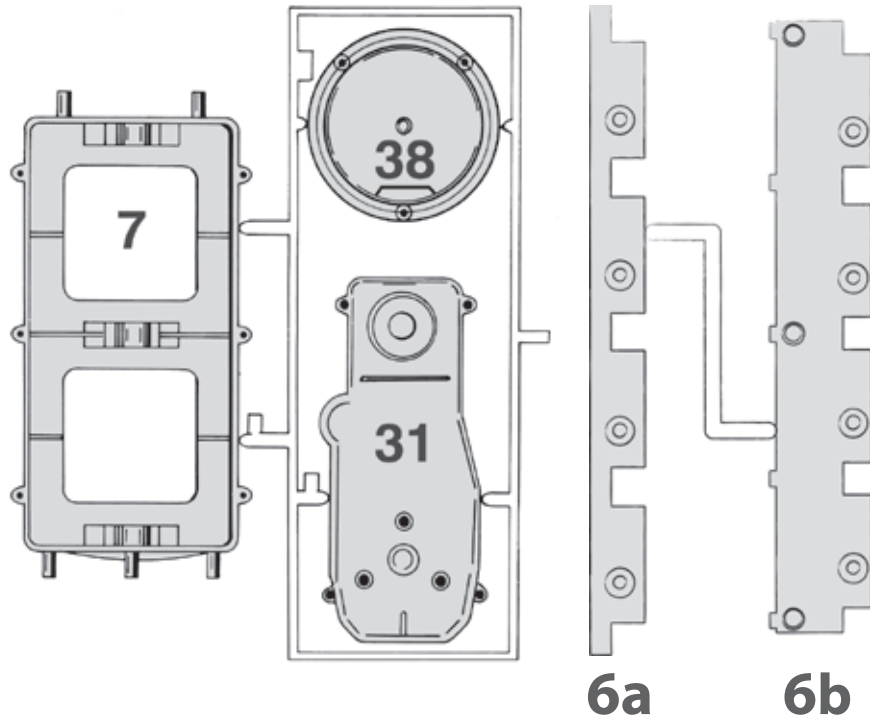

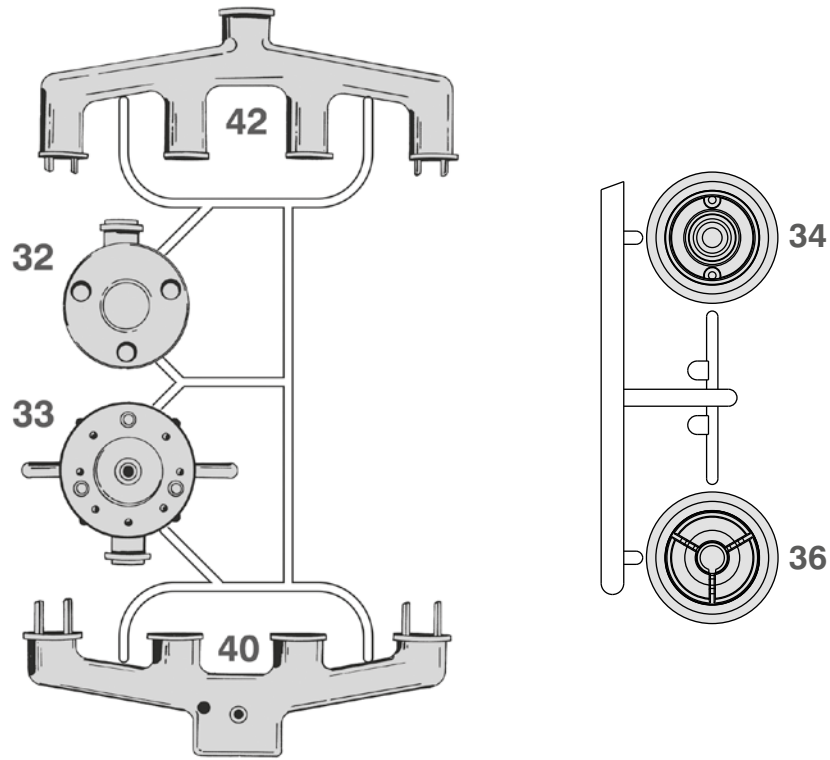

1. Fan belt (black)



2. Timing belt (green)

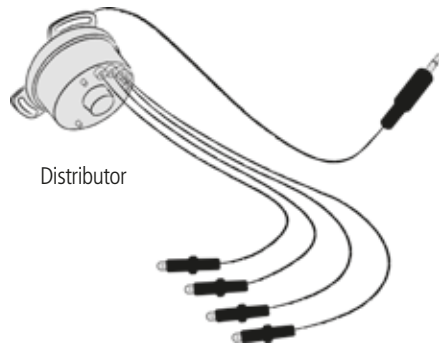

Distributor

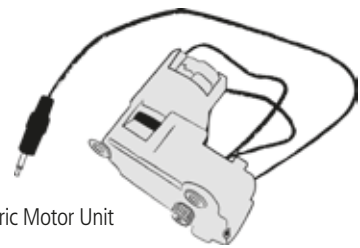

Electric Motor Unit

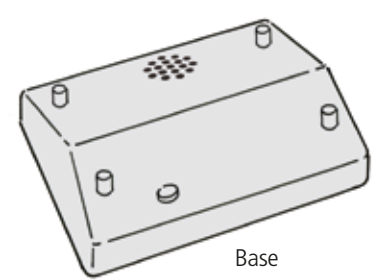
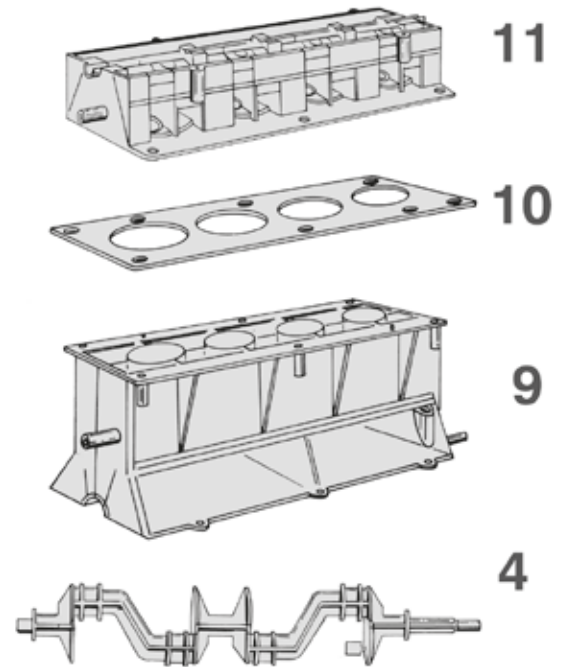

Base

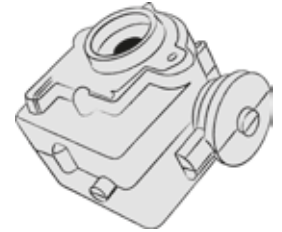

Throttle Body

Engine 2000 Screwdriver

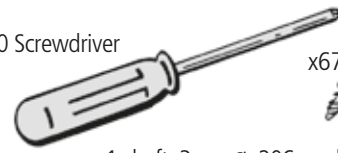

x67 screws

x8 valve springs

x 2 washers 9,5mm in Ø

1 shaft, 3mm Ø, 206mm long (half-round)

1 shaft, 3mm Ø, 156mm long

ASSEMBLING YOUR ENGINE

Note: use a sharp knife to trim any excess from the components after they have been removed from their carrier frames.

Assembling the pistons and connecting rods

- 1** Push a gudgeon pin (part 1) through the small end of a connecting rod (part 2).
- 2** Push two halves of a piston (part 3) on to the gudgeon pin, then press together firmly. Ensure the piston rotates freely.
- 3** Repeat steps 1 and 2 for the other three piston/rod assemblies.

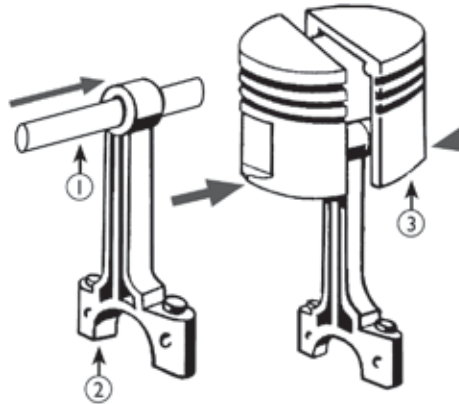

Fitting the piston/connecting rod assemblies on the crankshaft

- 4** The four connecting rods attach to the crankshaft (part 4) at the points indicated. Place the connecting rod over the crankshaft, then fit a bearing cap (part 5) and secure with two screws. Repeat for the other 3 piston/connecting rod assemblies.

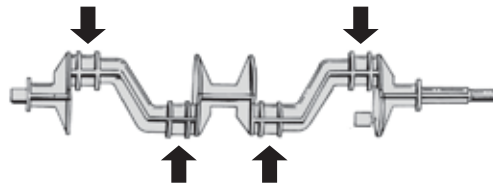

- 5** Check the completed assembly by turning the crankshaft. The piston/connecting rod assemblies should rotate freely.

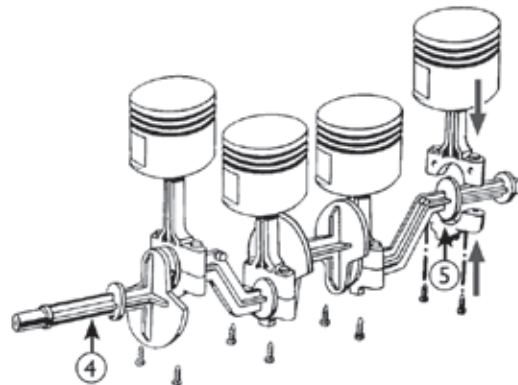

Fitting the sump pan

- 6** Place the sump pan (part 6) over the studs on the bottom of the lower crankshaft (part 7), and secure with four screws. Note that it will only fit in one way.
- 7** Turn the assembly over, and fit to the base. Secure with four screws.

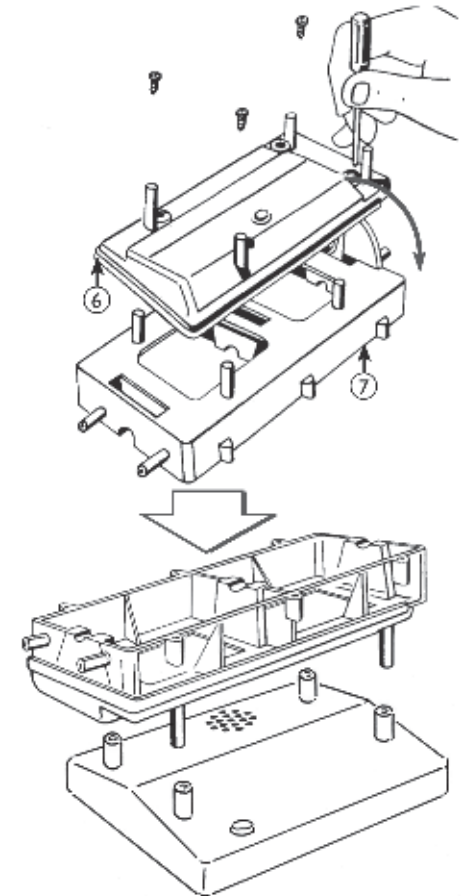

Fitting the piston/crankshaft assembly to the cylinder block

8 Rest the cylinder block (part 9) upside down.

9 Hold the piston/crankshaft assembly with the longer end of the crankshaft positioned at the end of the block with the single stud, as shown. The four pistons should slide easily into the cylinders. If not, you may need to scrape away any excess plastic from the inside edge of the cylinders. Lower the crankshaft until it rests on the bearing surfaces.

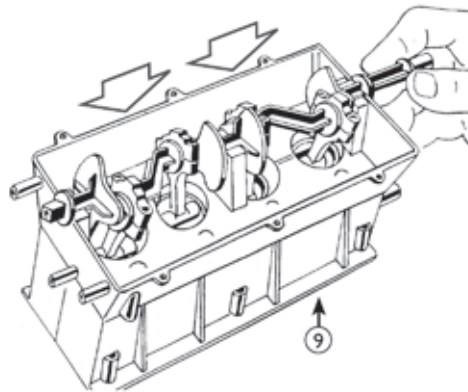

Fitting the cylinder block assembly to the lower crankcase

10 Turn the cylinder block the right way up, so the crankshaft is underneath. Hold the ends of the assembly, so the crankshaft stays in position. Fit this assembly to the lower crankcase, making sure that the longer end of the crankshaft is positioned above the end of the crankcase with two studs (as shown). Secure the cylinder block to the crankcase using six screws.

11 Gently turn the crankshaft by hand, making sure that it turns freely, and the pistons move smoothly in their cylinders.

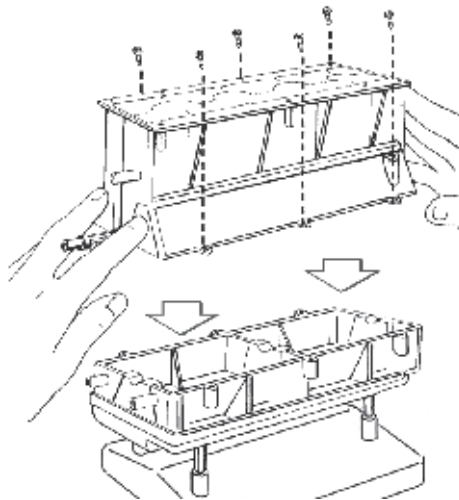

Fitting the springs to the valve stems

12 Remove the eight valve stems (part 12) from their carrier frames, and slide a spring over each one.

Fitting the valves to the lower cylinder head

13 Fit the two clear plastic cylinder head plates (parts 6a and 6b) to the lower cylinder head (part 11). Each plate has four round studs which face downwards, into the lower cylinder head. The narrower plate (6a) fits on the side with the smaller holes in the lower cylinder head, the wider plate (6b) on the side with the larger holes. The plates must be pushed down firmly so they clip into position.

14 The studs in the narrower plate carry the exhaust valves. Pick up the lower cylinder head, then slide a valve stem into one of the holes. Gently push the valve stem, compressing the spring until the end of the stem sticks out the bottom of the head. Carefully push the exhaust valve (part 13) on to the stem. Note that the end of the valve stem has a step – push the valve until it touches the edge of the step. Do not force the valve – if necessary, trim any excess plastic from the stem. Repeat for the other three exhaust valves.

15 The studs in the wider plate carry the inlet valves (part 14). Fit these as described above for the exhaust valves.

16 Check that the valves operate correctly – each should move up and down smoothly without sticking.

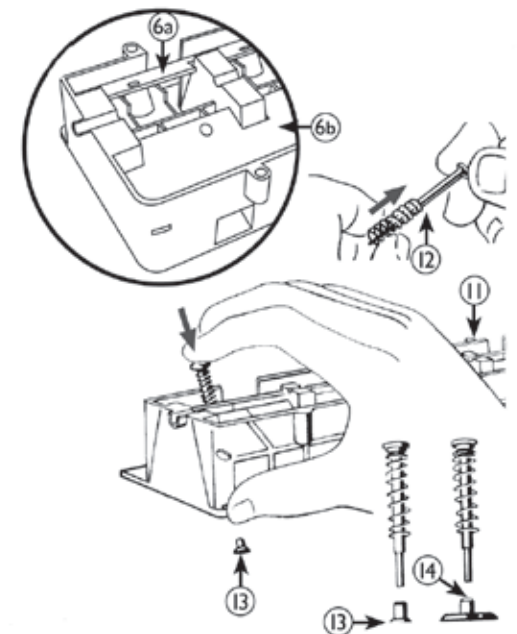

Fitting the rocker arms to the rocker shaft

17 Remove the eight rocker arms (part 24) from the carrier frame. Slide the rocker arms on to the metal rocker shaft (3mm diameter/156mm long). The arms must be fitted as shown in the diagram. Note that each successive rocker arm is fitted the opposite way round to the previous arm. Also carefully note the position of the rocker arms in relation to the upper cylinder head - use the studs on either end of the head as a point of reference.

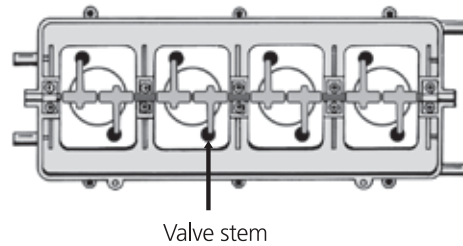

Fitting the rocker arm assembly to the upper cylinder head

18 Lower the rocker arm assembly on to the upper cylinder head (part 23). Use your fingers to separate the rocker arms into pairs on the shaft, so they fit into the four rectangular holes in the head. The longer arms of the rockers must be positioned over the valve stems.

19 Fit the bearing caps (part 25) as shown using ten screws. Do not overtighten, and check that all rocker arms move smoothly.

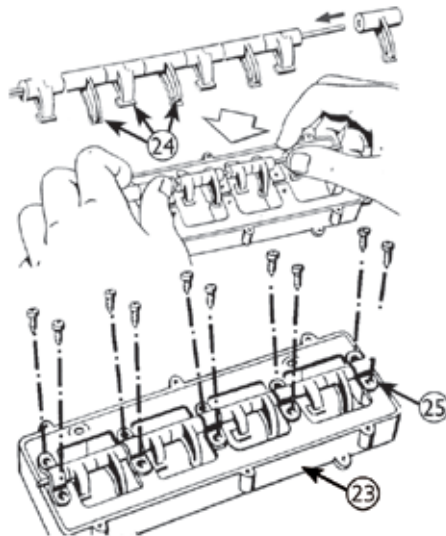

Fitting the cylinder head gasket to the cylinder block

20 Place the cylinder head gasket (part 10) over the cylinder block, using the holes in the gasket to ensure correct alignment.

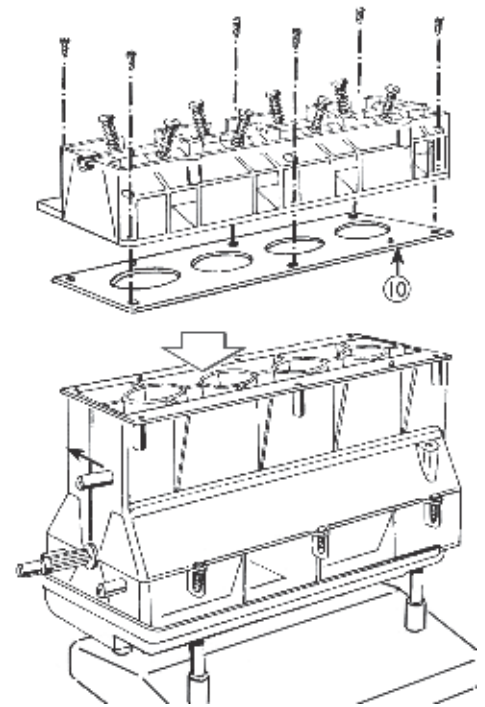

Fitting the lower cylinder head to the cylinder block

21 Fit the lower cylinder head to the cylinder block. Make sure the end of the cylinder head with the round stud is fitted at the end of the block with the five studs sticking out.

22 Secure the cylinder head to the block using six screws.

Assembling the camshaft

23 Remove the eight cams (labelled A to H) from the plastic carrier frame. Slide the cams onto the camshaft (3mm diameter/206 mm long), in the following order-A,B,C,D,E,F,G and H. Each cam will only fit in one position. There is a flat surface on the inside of each (refer to the enlarged portion of the diagram), which matches the flat surface on the camshaft. Please also note the rib on one end of each cam. The cams must be fitted so the ribbed portions all face one way (towards the left in the diagram).

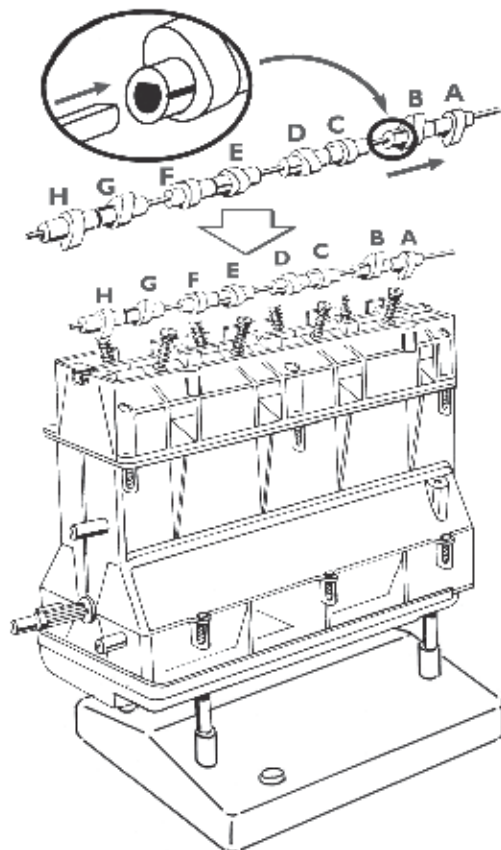

Fitting the camshaft to the lower cylinder head

24 Position the engine so the longer, splined (ribbed) end of the crankshaft is on your left.

25 Hold the camshaft with cam H on your left, and then lower on to the cylinder head. Use your fingers to separate the cams into pairs, so that each pair fits between the bearings in the head. The cam shaft should rest in each of the five bearing surfaces. Again, make sure that the raised ribs on the cams all point towards the longer end of the crankshaft.

Fitting the upper cylinder head to the lower cylinder head

26 Fit the upper cylinder head assembly (from step 19) to the engine. The end with the two wider spaced studs should be positioned over the end of the cylinder block with three studs sticking out. Check that all of the rocker arms are positioned over the top of the valve stems. Push down on each rocker arm to make sure that they move their corresponding valve. Secure the upper cylinder head with four screws.

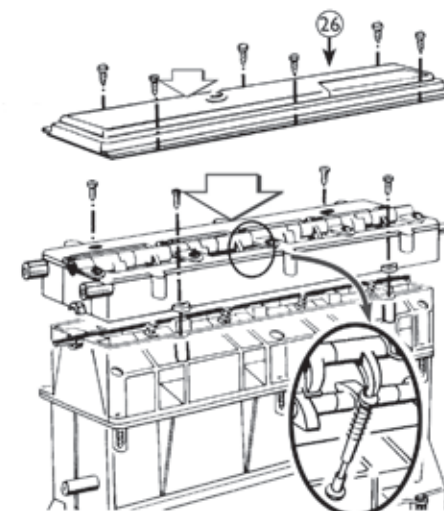

Fitting the rocker cover

27 Fit the rocker cover to the top of the cylinder head and secure with six screws.

Fitting the crankshaft sprocket

28 Push the crankshaft sprocket (part 27) on to the longer, splined end of the crankshaft, with the toothed side facing away from the engine. There is a slot in the sprocket that matches a rib on the crankshaft. Turn the sprocket, until it slides on smoothly.

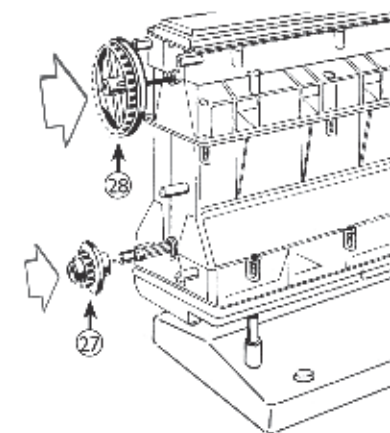

Fitting the camshaft sprocket

29 Push the camshaft sprocket (part 28) on to the camshaft, again making sure that the toothed side faces away from the engine. The flat in the hole in the sprocket lines up with the flat on the camshaft.

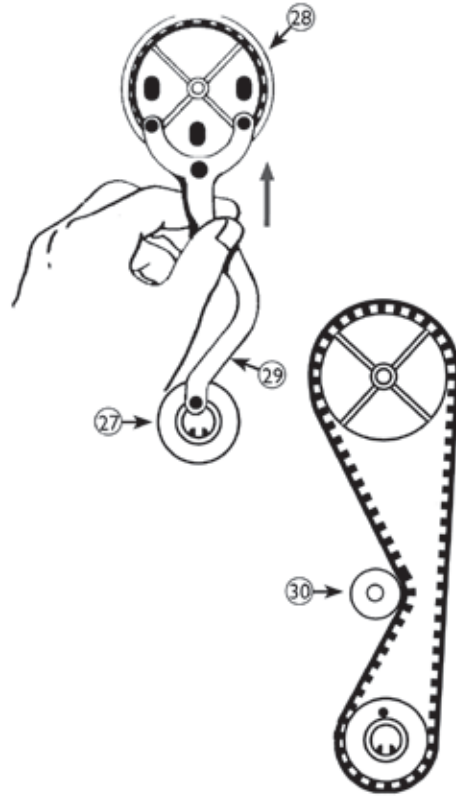

Fitting the timing alignment tool

30 The alignment tool is used to lock the crankshaft and camshaft sprockets in position while the timing belt is fitted. Carefully turn the sprockets until they are in the positions shown. Fit the alignment tool to the crankshaft sprocket first, followed by the camshaft sprocket.

Fitting the timing belt and idler pulley

31 It is easier to complete this step with the engine held between your knees, so the sprockets are facing upwards. Carefully fit the timing belt on to the sprockets, making sure the teeth on the belt engage with the teeth on the sprockets. The belt should be tight between the sprockets on the right-hand side of the engine, with all slack on the left-hand side. The slack is taken up when the idler pulley is fitted. Push the idler pulley (part 30) against the smooth side of the timing belt and then slide it on to the stud on the end of the block, as shown. Once the timing belt and idler pulley have been fitted, remove the alignment tool, taking care not to dislodge the parts just fitted.

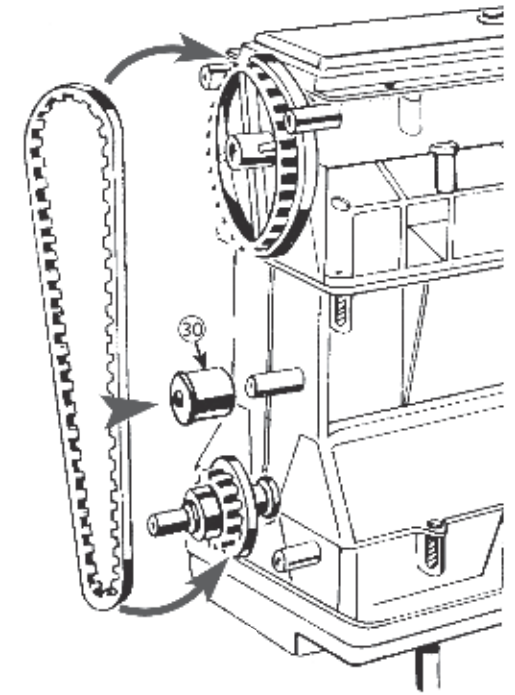

Fitting the timing belt cover

32 Fit the timing belt cover (part 31) over the timing belt and sprockets and secure with four screws.

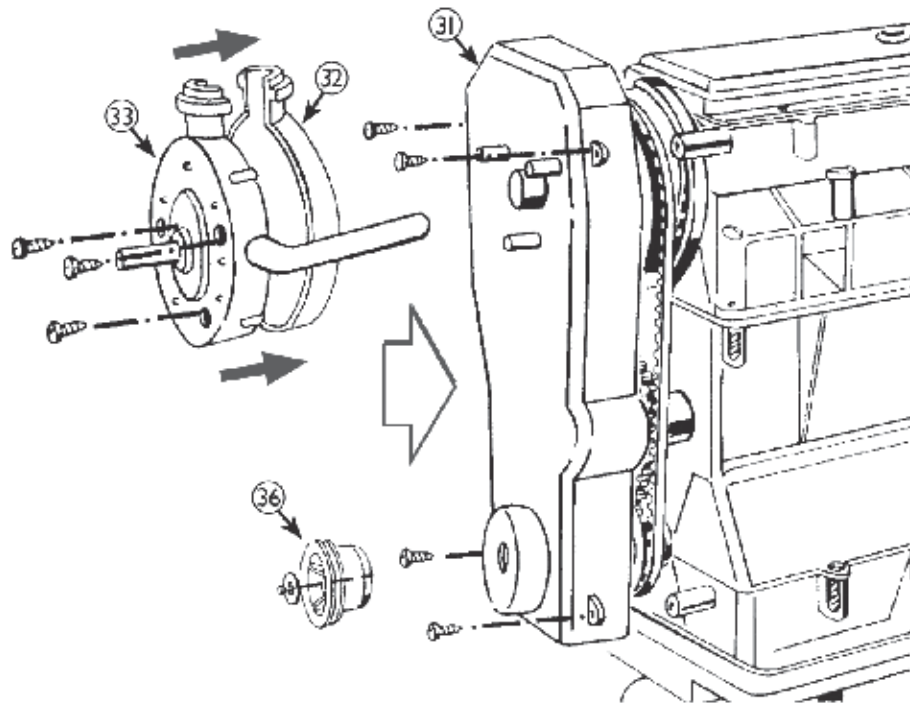

Fitting the water pump

33 Assemble the front and rear halves of the water pump (parts 33 and 32). Fit this to the three studs on the front of the timing belt cover, then secure with three screws. Refer to the illustration for guidance.

34 Fit the crankshaft pulley (part 36) to the crankshaft. The slot in the pulley must line up with the rib on the crankshaft in order to slide into position. Secure the pulley with a single screw and washer, as shown.

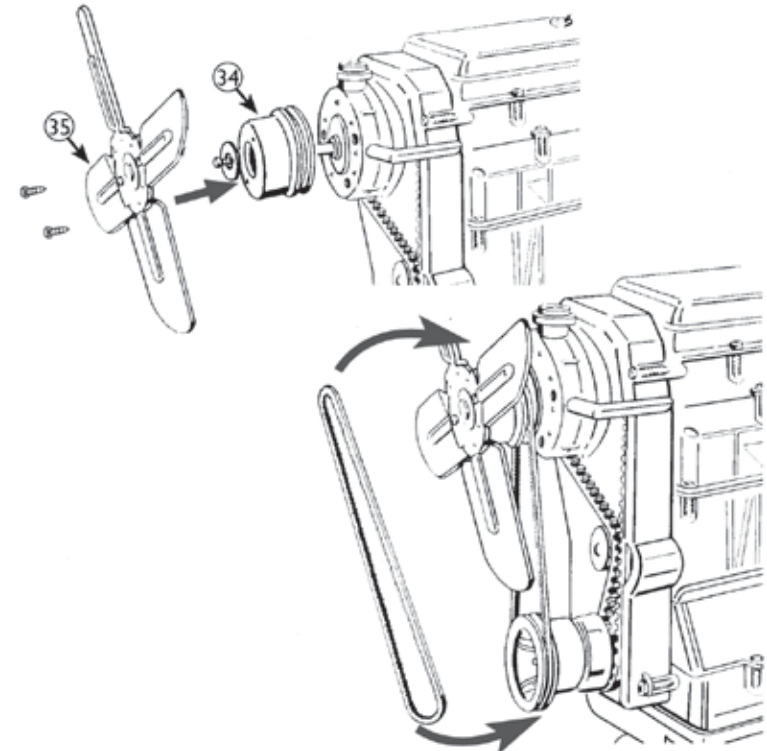

Fitting the fan pulley, fan and fan belt

35 Fit the fan pulley (part 34) to the shaft on the front of the water pump. Fix the pulley to the pump using a single screw and washer, as shown.

36 Fix the fan (part 35) to the fan pulley using two screws. Note that the raised ribs on the fan blades face outward.

37 Carefully loop the fan belt over the fan blades so that it rests on the fan belt pulley. Pull the other end down and loop it over the crankshaft pulley. The toothed side of the belt should fit against the pulleys.

Fitting the flywheel

38 Fit the flywheel (part 37 - the toothed wheel) to the opposite end of the crankshaft to the crankshaft pulley. The toothed part of the flywheel should be positioned furthest away from the end of the engine.

Positioning the pistons and camshaft

39 Gently turn the crankshaft by hand so that No. 4 piston (at the water pump/cam belt end of the engine, also marked on the side of the cylinder head) moves to its highest point – the “Top Dead Centre or TDC” position. Check that the flat on the camshaft is facing downwards; if it is facing upwards, continue to rotate the crankshaft until No. 4 piston reaches its next TDC position.

Fitting the batteries

40 Fit 2 x AA/LR6 batteries to the base, making sure they are positioned in accordance with the markings in the compartment.

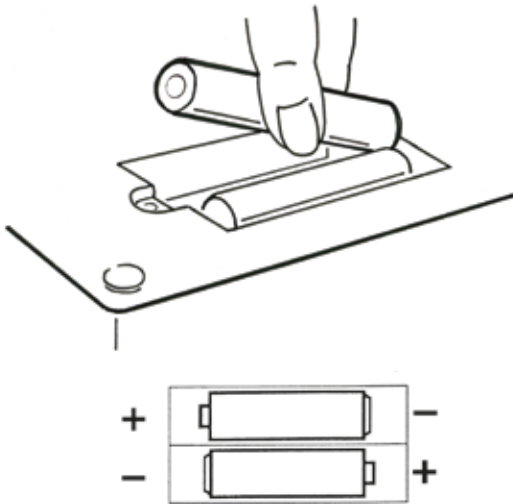

Battery safety

- Non-rechargeable batteries are not to be recharged
- Rechargeable batteries are only to be charged under adult supervision
- Rechargeable batteries are to be removed from the toy before being recharged
- Different types of batteries or new and used batteries are not to be mixed
- Batteries are to be inserted with the correct polarity
- The supply terminals are not to be short circuited
- Do not dispose of batteries in the fire
- Always turn off the unit when changing batteries
- Exhausted batteries are to be removed from the toy
- Do not connect the toy to more than the recommended number of power supplies

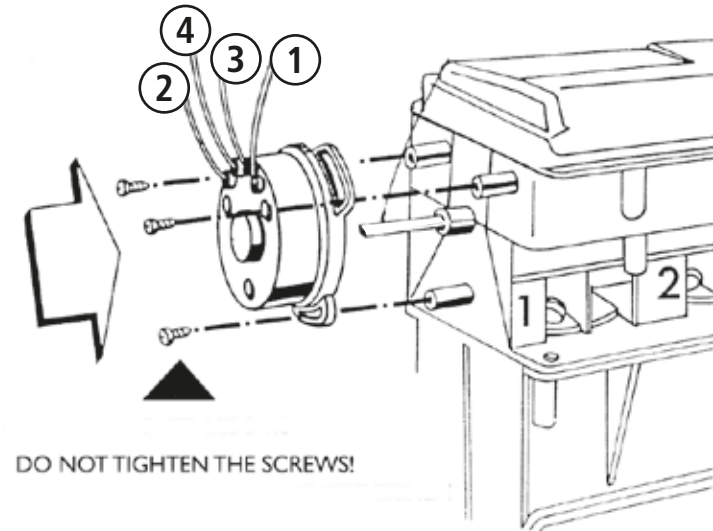

Fitting the distributor

41 Fit the distributor to the end of the camshaft as shown, with the wires positioned at the top. Insert three screws into the corresponding lugs in the cylinder head, but DO NOT tighten them yet. Take care not to turn the camshaft. Connect the distributor to the battery box.

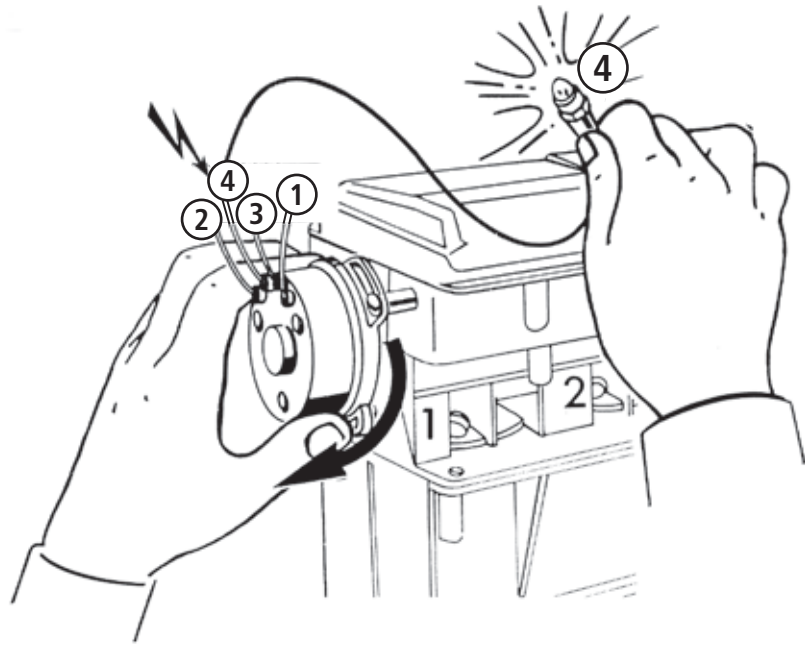

Adjusting the ignition timing

42 Follow the wire from the "4" marked on the distributor cap to the bulb (which represents the No. 4 spark plug). Hold the bulb, then adjust the ignition timing as follows: press the red button on the battery box and gently turn the distributor until the bulb is illuminated. Carefully tighten the three distributor securing screws. Check the ignition timing again to make sure the No. 4 bulb still illuminates.

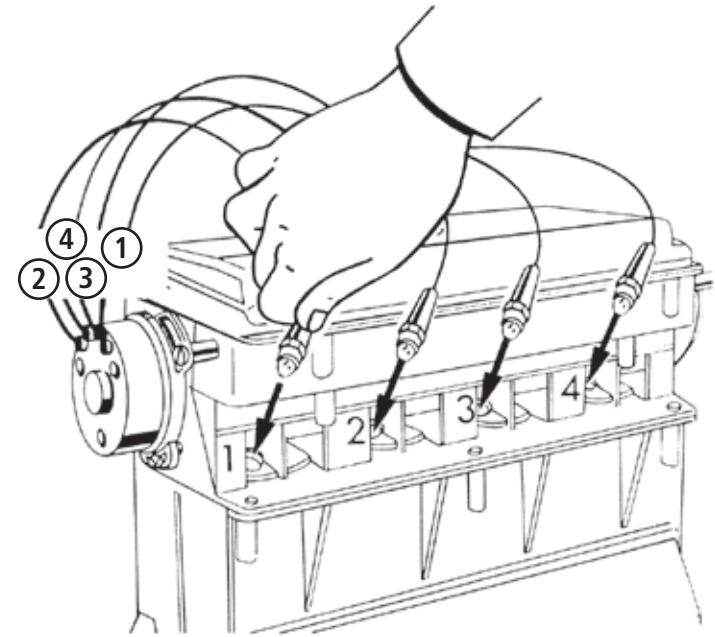

Fitting the spark plugs

43 Fit the No. 4 bulb to the hole marked "4" on the cylinder head, Follow the three other wires from the "1", "2" and "3" markings on the distributor cap to their respective bulbs, and fit these to the corresponding holes in the cylinder head.

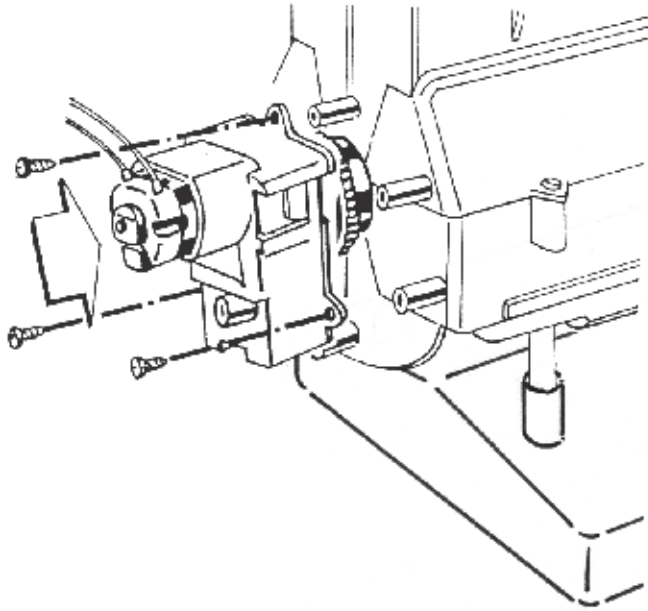

Fitting the electric motor unit

44 Slide the motor unit into position over the flywheel, making sure that the gear on the motor and flywheel engage. The three mounting holes on the motor unit should line up with the studs on the engine, as shown. Secure the motor unit using three screws.

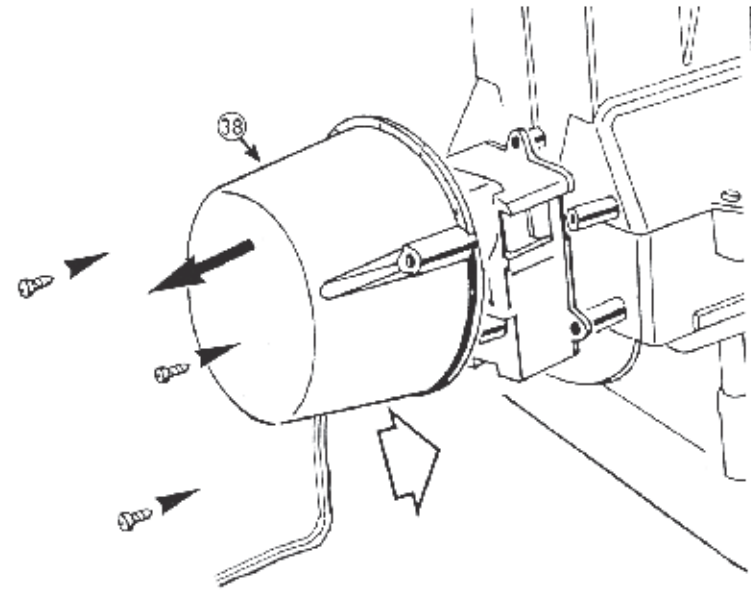

Fitting the clutch cover

45 Feed the wire from the motor unit through the hole in the clutch cover (part 38). Fit the clutch cover to the engine, using three screws to secure it in place.

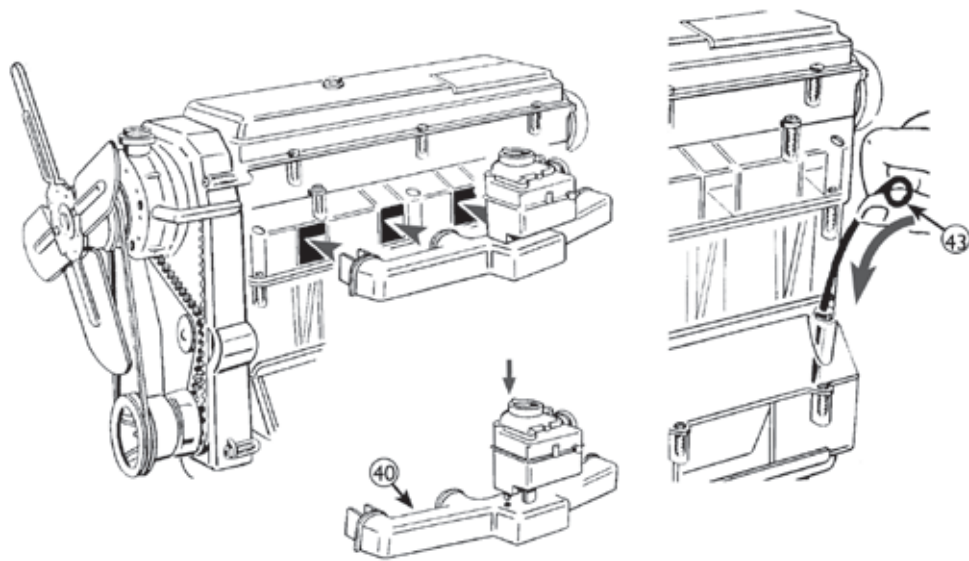

Fitting the inlet manifold/throttle body assembly

46 Fit the throttle to the inlet manifold (part 40). Note the locating pin in the bottom of the throttle, and the corresponding hole in the manifold, as shown. Secure with a screw.

47 Push the manifold/throttle assembly to the engine, on the opposite side to the spark plugs.

Fitting the dipstick

48 Slide the dipstick (part 43) into the hole in the engine (below the inlet manifold, next to the clutch cover).

Fitting the exhaust manifold

49 Push the exhaust manifold (part 42) into position on the spark plug side of the engine, as shown.

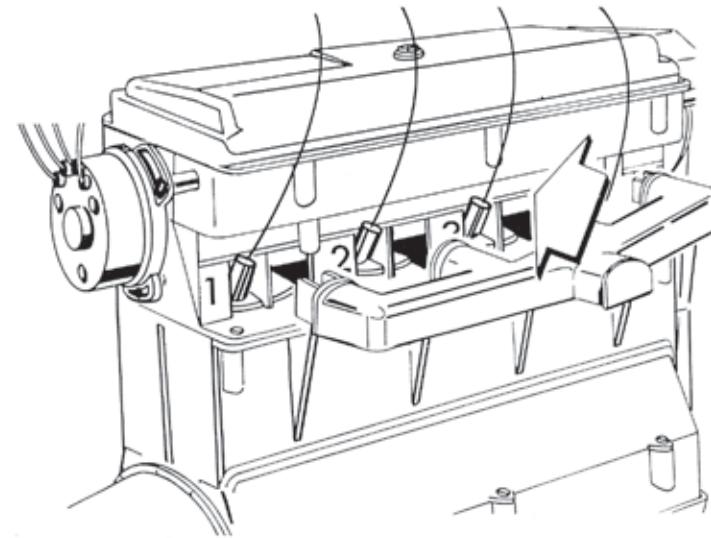

HOW A PETROL ENGINE WORKS

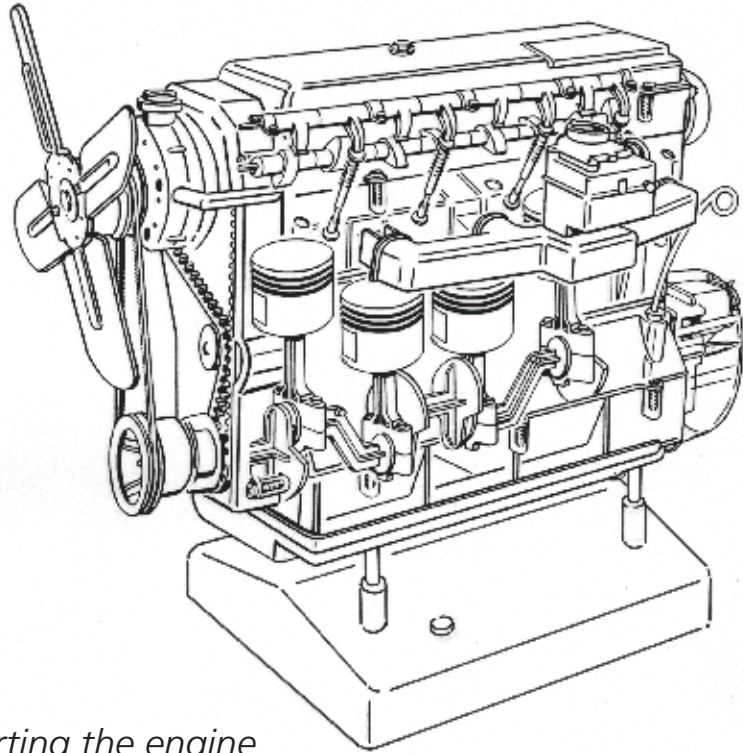

Starting the engine

50 Plug both the distributor wires and electric motor unit into the base. Press the red "Start" button - the engine will run for approximately 45 seconds.

You've now built a working model of a real car engine, and you've earned your Haynes Engineer Certificate, which you can download and print from www.haynes.co.uk/engine

Basic principles

To explain how a full-size car engine works, we'll use a simplified version of a real engine - our model engine in fact. You can switch on your finished model as you read this explanation and it will help you to understand how a real engine works.

The crankshaft is called a crankshaft because it is a 'cranked' shaft - the shaft has four cranked sections and the piston/connecting rod assemblies connect to these cranked sections. As the crankshaft turns, the cranked sections rotate around the centreline of the crankshaft and this allows the pistons to move up and down as the crankshaft turns.

When the piston moves down, it pushes the connecting rod down, which pushes against the cranked part of the crankshaft, making the crankshaft rotate. This converts the up-and-down movement of the piston into the turning movement of the crankshaft.

The engine's crankshaft drives the transmissions, which includes various different components connected together whose job it is to drive the car's wheels, making the car move.

Now let's look at how the engine works in more detail. We'll look at just one cylinder of the engine. A cylinder is the hollow cylinder inside the engine in which one piston moves up and down. The piston has seals, called piston rings, around its edge, which aren't shown on our model and these seals stop gases passing round the sides of the piston. Our model has four cylinders, like the most common full-size engines.

When you turn the engine to start the car, the starter (a powerful electric motor, powered by the car's battery) turns the crankshaft, moving the pistons up and down.

As a piston moves down from its highest position inside the cylinder (called 'Top Dead Centre' or 'TDC'), a mixture of petrol and air is sucked into the space inside the cylinder above the piston. This is called the **intake** stroke.

The starter continues to turn the crankshaft and, as the piston moves back up towards the top of its cylinder, the petrol/air mixture is compressed (squashed) in the space above the piston. This is called the **compression** stroke.

As the piston reaches its highest point, a spark plug creates a spark above the piston and this spark ignites the petrol/air mixture, causing a small controlled explosion above the piston. The explosion pushes the piston downwards and this is called the **power** stroke.

Once the piston has reached its lowest point, it starts to move back up its cylinder, pushing the burnt gases out through the top of the cylinder. This is called the **exhaust** stroke.

So, the engine has four strokes; intake, compression, power and exhaust, or 'suck', 'squeeze', 'bang' and 'blow' to make it simpler. These four strokes make up the 4-stroke cycle.

The petrol/air mixture flows into the space above the piston, called the combustion chamber. The mixture flows in through a small hole which is opened and closed by the inlet valve. The burnt gas flows out of the cylinder through another hole which is opened and closed by the exhaust valve. The valves are normally held closed by springs, but as the engine turns the valves are pushed open in the correct order by the rocker arms, which are moved by the camshaft. The rocker arm pushes the valve down against its spring and, as the rocker moves up, the spring pushes the valve closed.

4-stroke cycle

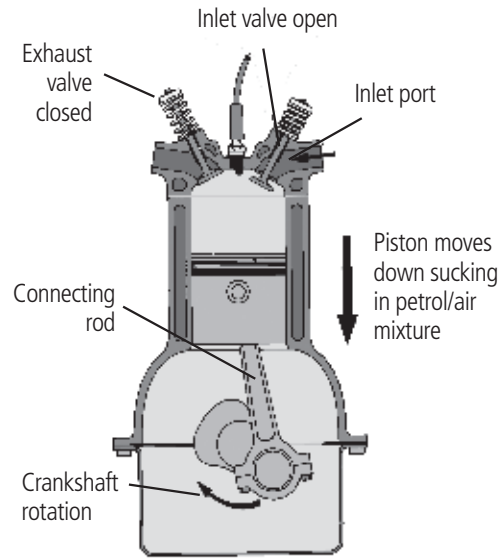

The 1st stroke (intake)

The piston starts off at the top of the cylinder. The exhaust valve is closed and the inlet valve is open. As the crankshaft turns and the piston moves down inside the cylinder, petrol/air mixture is sucked in through the inlet valve. When the piston reaches its lowest point inside the cylinder, the cylinder is filled with petrol/air mixture and the inlet valve closes. This is the end of the intake stroke.

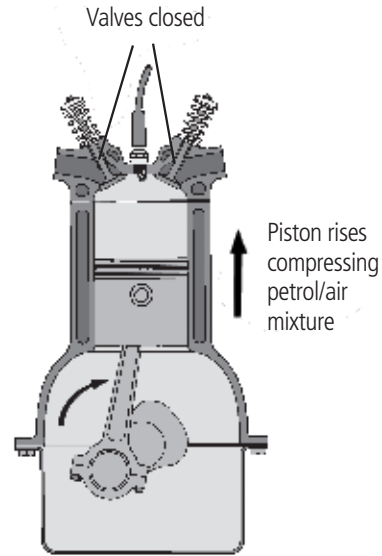

The 2nd stroke (Compression)

At the start of the compression stroke, the piston is at its lowest point inside the cylinder and the inlet and exhaust valves are closed. The crankshaft continues turning and the piston moves upwards. As the piston moves upwards it squeezes (compresses) the petrol/air mixture and this increases the temperature of the mixture very quickly. When the piston reaches its highest point the mixture is fully compressed and this is the end of the compression stroke.

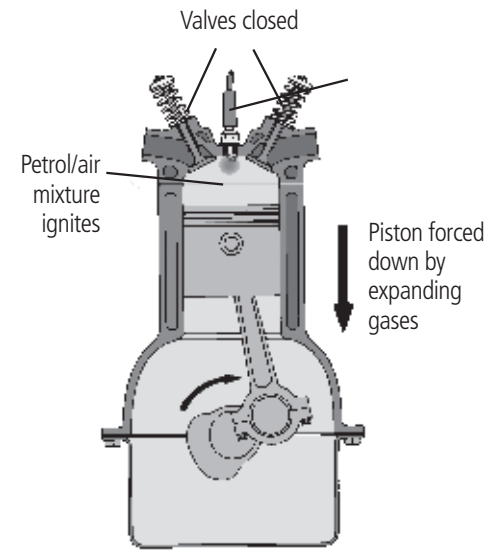

The 3rd stroke (Power)

The very high pressure and temperature inside the combustion chamber cause the petrol/air mixture to break up into very fine particles, like a mist. These are perfect conditions for burning a gas. All that's needed to start the burning (or 'combustion' - a kind of controlled explosion) is a spark. A very high electrical voltage supplied to the spark plug causes a spark to jump across the gap at the end of the spark plug. This ignites the petrol/air mixture and starts the combustion. The force of the controlled explosion and the expanding gases forces the piston downwards, which pushes the crankshaft round. During the power stroke, three things happen to the petrol/air mixture - it ignites, combusts (burns) and expands. The expansion of the gas pushes the piston down, which transfers power to the crankshaft. When the piston reaches its lowest point inside the cylinder this is the end of the power stroke.

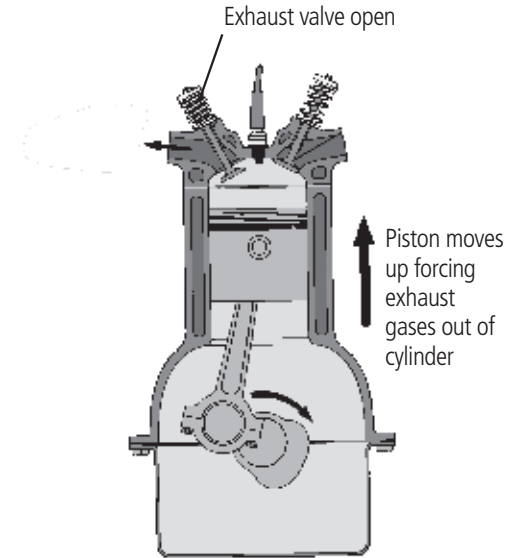

The 4th stroke (Exhaust)

As the piston starts to move up inside the cylinder again, the exhaust valve opens to allow the burnt (exhaust) gas to escape from the cylinder and as the piston moves up the cylinder it pushes the gas out through the exhaust valve. As the piston reaches the top of the cylinder the exhaust valve closes, the exhaust stroke ends and the 4-stroke cycle begins again with another intake stroke.

Multi-cylinder engines

So far, we've explained how the engine works by describing what happens in one cylinder. A car engine will actually have more than just one cylinder - anything from two (quite rare) to 16 (in the most expensive high-performance cars), but the most common number for everyday cars is 4. If an engine had only one cylinder it would vibrate a lot and make a car very uncomfortable. To make the engine run smoothly, the spark plugs fire in a regular order called the 'firing order' and for most four-cylinder engines the firing order is 1-3-4-2. You can see this on the model engine by watching the spark plugs fire - No. 1 cylinder is the one closest to the distributor.

The model engine

You can see how the 4-stroke cycle works by starting your model engine and watching how the components inside move. Watch how the camshaft and rockers move the valves as each piston moves up and down inside its cylinder. If you watch the piston in one cylinder, you should be able to recognise the four strokes - watch the valves and see if you can tell which stroke is which.

Remember that:

- On the intake stroke the piston moves down, the inlet valve is open and the exhaust valve is closed.
- On the compression stroke, the piston moves up and the inlet and exhaust valves are closed.
- On the power stroke, the piston moves down and the inlet and exhaust valves are closed.
- On the exhaust stroke, the piston moves up, the inlet is closed and the exhaust valve is open.

The exhaust valves are all on the exhaust manifold side of the engine and the inlet valves are on the inlet manifold/throttle body side.

You'll notice that all four cylinders in the model engine are on different 'strokes' - watch how the pistons move as the crankshaft turns and you'll see that the pistons move in pairs and, when two of the pistons are at the tops of their cylinders, the other two are at the bottom. Even though two of the pistons may be at the tops of their cylinders, the pistons will be on different strokes - one will be about to move down at the start of its intake stroke and the other will be about to move down at the start of its power stroke. You can tell which piston is about to start of its power stroke because the spark plug will fire (the bulb will light) in the cylinder head above the piston which has just reached the end of its compression stroke and is just about to start its power stroke.

What does the ignition system do?

The ignition system produces the sparks which are used to ignite the petrol/air mixture in a petrol engine (diesel engines don't have an ignition system). The ignition coil changes the low voltage electricity from the battery into high-voltage electricity which is sent along the HT (High Tension) leads to the spark plugs. The spark plugs are screwed into the cylinder head and produce sparks inside the combustion chambers.

What does the fuel injection system do?

All modern petrol engines are fitted with a fuel injection system.

There are two basic types of fuel injection system, single-point and multi-point. A single-point fuel injection system has a single fuel injector which sprays petrol into the inlet manifold where it's mixed with air before passing into through the engine's inlet valves into the cylinders. A multi-point fuel injection system works in exactly the

same way, except that a separate fuel injector is used to fuel each cylinder.

What do emissions control systems do?

When the petrol/air mixture is burnt inside the engine, exhaust gases are produced. The exhaust gases pass through the car's exhaust system out into the atmosphere, causing pollution. These gases are known as exhaust emissions and all engines have emissions control systems fitted to reduce harmful pollution.

What does an engine management system do?

An engine management system is controlled by an electronic control unit (ECU) which is connected to various sensors and actuators fitted around the engine. The sensors monitor the engine operating conditions and produce electrical signals which are sent to the ECU. The ECU processes all the information from the sensors and is able to tell exactly what conditions the engine is running under. The ECU then sends signals to the ignition, fuel injection and emission control systems to control the engine.

An engine management system allows very fine control of the engine and the ECU makes sure that the engine operates as efficiently and smoothly as possible, which means that it uses less fuel and causes less pollution.

Why does an engine need oil?

Oil is the engine's blood. The engine needs oil for two reasons - to reduce the friction between the moving parts and to help keep the engine cool.

Some of the metal components inside the engine move at a very high speed very close

together, and they rely on a thin film of oil between them to prevent the components from rubbing together. If the components rub together they will very quickly overheat and seize up, which can wreck the engine.

When the engine is stopped, the oil is stored in a tray called the sump, bolted to the bottom of the cylinder block. When the engine is running, the oil is pumped from the sump to all moving parts of the engine through small passages in the cylinder block and cylinder head. The oil pump is driven by the engine, usually from the crankshaft. As the oil circulates through the engine, it picks up tiny particles of dirt and, as the engine wears, tiny particles of metal, which would eventually damage the engine's moving parts. The oil passes through an oil filter which catches these small particles; the oil filter is one of the most important parts of the engine. Eventually, the oil filter starts to clog up and the oil can't flow through as easily, so it must be changed whenever the engine oil is changed at the recommended service intervals.

The amount of oil inside the engine can be checked using a 'dipstick' - if the oil level is low it can damage the engine very quickly. If the oil level is checked often and the oil and filter are changed at the recommended intervals, the engine will stay healthy.

Why does the engine have a cooling system?

Why does the engine have a cooling system? The cooling system is vital because it stops the engine overheating. It also keeps the engine at the best temperature for it to work efficiently, which means that it will use less petrol and will produce less harmful exhaust emissions.

The coolant is pumped around the passages inside the engine by the coolant (water) pump, collecting heat from the engine components as it flows through. The

hot coolant then passes from the engine to the radiator (mounted at the front of the car under the bonnet), where the air is forced through the radiator as the car moves forward and cools it. The cooling fan draws cool air over the radiator when the speed of the car is too low (or if the car is stopped), or if the air temperature is too high to give enough cooling. The cooling pump is usually driven by a belt, sometimes by the timing belt and sometimes by a separate auxiliary (or 'fan') belt.

What's the difference between a petrol engine and a diesel engine?

Most types of cars now come with the option

of a petrol or diesel engine. Diesel engines use diesel fuel instead of petrol and the biggest difference in the way petrol and diesel engines work is the way that the fuel burns. A petrol engine needs a spark plug to ignite the petrol with a spark but in a diesel engine there's no spark plug and the fuel ignites itself due to the high pressure and temperature inside the combustion chamber. Because diesel engines need a high temperature to ignite the fuel, when they are first started from cold they use 'glow plugs' to heat the fuel/air mixture to a high enough temperature to ignite. Generally, diesel engines use less fuel than petrol engines and they produce less pollution.

So, now you have a good idea of how an engine works.

KEEPING A CAR AND ITS ENGINE HEALTHY

There are a few simple checks that can be done once a week to keep a car and its engine in good condition. These checks will only take about ten minutes and the handbook that comes with the car, or the right Haynes Service and Repair Manual for the car, will explain how to carry out these checks. You can also see how to carry out these checks on the Haynes website at www.haynes.co.uk

Weekly checklist:

- Check the engine oil level
- Check the engine coolant level
- Check the brake fluid level
- Check the windscreen washer fluid level, and check that the washers and windscreen wipers work
- Check that the wiper blades are in good condition
- Check the tyre pressures and check that the tyres aren't damaged or worn
- Check the power steering fluid level, if the car has power steering

REDUCING POLLUTION AND SAVING ON FUEL BILLS

Using less fuel saves money and also reduces pollution and it's easy to do both by bearing in mind a few simple points. All the following points increase the amount of fuel used and so increase pollution.

- Towing a trailer or caravan and carrying heavy loads
- Driving the car with a roofbox or roof bars fitted
- Lots of short journeys
- Driving with low tyre pressures

So, if the driver thinks about all these points it's easy to cause less pollution and save money too! For more information on things you can easily do to help reduce the pollution a car causes, see the Haynes website at www.haynes.co.uk

Here's a list of common terms connected with a car engine, with simple explanations of what they mean.

Air filter – A paper or foam filter that removes dirt from the air that's sucked into the engine.

Alternator – An electrical generator driven by the engine. It provides electricity for the car's electrical system when the engine's running, and to charge the battery.

Antifreeze – A fluid that's added to water to produce engine coolant. The antifreeze stops the coolant freezing in cold weather and prevents corrosion inside the engine.

Battery – A 'reservoir' that stores electricity. Provides the power to start the engine and power for the electrical systems when the engine is stopped, and is charged by the alternator when the engine's running.

Bearing – A metal or other hard-wearing surface that another part moves against. A bearing is designed to reduce friction and wear and is usually lubricated with oil or grease.

Big-end – The lower end of a **connecting rod** attached to the engine's **crankshaft**. It has a bearing and transmits the movement of the connecting rod to the crankshaft.

Bore – A term used to describe the diameter of a cylinder in an engine.

Breather – An opening or valve that allows air or fumes out of the engine, or fresh air into the engine.

Cam belt – See **Timing Belt**.

Cam follower (tappet) – A component fitted between the **camshaft** and a valve to operate the **valves**.

Camshaft – A rotating shaft driven from the **crankshaft**, with cams that push the valves open.

Catalytic converter – A device fitted in the

exhaust system that reduces the amount of harmful gases released into the atmosphere.

Clutch – A part that allows two separate rotating components to be coupled together smoothly, without the need for either component to stop moving.

Combustion chamber – A shaped area into which the fuel/air mixture is compressed by the **piston** and where the mixture is ignited. The combustion chamber may be in the **cylinder head**, or sometimes in the top of the **piston**.

Compression ratio (CR) – A term to describe the amount by which the fuel/air mixture is compressed as a **piston** moves from the bottom to the top of its travel.

Connecting rod (con rod) – A metal rod in the engine connecting a **piston** to the **crankshaft**. The connecting rod transfers the up-and-down motion of the piston to the crankshaft.

Coolant – A mixture of water and **antifreeze**, used in a car's engine cooling system.

Coolant (water) pump – A pump driven by the engine that pumps the coolant around the cooling system.

Cooling fan – Electric or engine-driven fan mounted at the front of the engine compartment and designed to cool the **radiator**.

Crankcase – The area of the **cylinder block** below the **pistons**, which houses the **crankshaft**.

Crankshaft – A cranked metal shaft that changes the up-and-down motion of the **pistons** and **connecting rods** into a rotary motion.

Cylinder – A metal tube in the engine in which a piston slides.

Cylinder block – The main engine casing, which houses the cylinders, crankshaft, pistons and connecting rods.

Cylinder head – The casing at the top of the

engine that houses the valves and valve gear. The cylinder head is bolted to the **cylinder block**.

Cylinder head gasket – The gasket that makes a seal between the **cylinder head** and the **cylinder block**.

Dipstick – A metal or plastic rod used to check the engine oil level.

Distributor – A device used to distribute the ignition HT circuit current to the individual **spark plugs**.

DOHC – Double Overhead Camshafts. An engine with two **camshafts**, where one operates the inlet **valves**, and the other operates the exhaust valves.

Drivebelt – A belt, usually made from rubber, used to transmit drive between two pulleys or sprockets. Often used to drive the **camshafts** and engine ancillaries.

Emissions – Harmful substances (gases or particles) released into the atmosphere from a car's engine.

Emissions control – A way of reducing the **emissions** released into the atmosphere.

Engine management system – A system which uses an electronic control unit to control the **ignition system** and **fuel injection** system, improving engine efficiency and reducing emissions.

Exhaust manifold – A ducting used for directing the exhaust gases from the engine's **cylinder head** into the exhaust system.

Fan belt – Another term for a drivebelt.

Fault code – An electronic code stored in the memory of an electronic control unit which gives details of a fault detected by the self-diagnostic system. A diagnostic light on the instrument panel will usually come on to indicate a fault.

Firing order – The order in which the **pistons** in the cylinders of an engine reach their **firing points**.

Firing point – The instant at which the fuel/air mixture in the **cylinder** of an engine ignites in the **combustion chamber**.

Flywheel – A heavy metal disc attached to one end of the **crankshaft** in an engine, used to smooth out the power pulses from the **pistons**.

Four-stroke – A term used to describe the four operating strokes of a **piston** in a car engine.

Fuel injection – A method of injecting a measured amount of fuel into an engine.

Fuel injector – A device used to inject fuel into an engine. Some engines use a single fuel injector, whilst some use one fuel injector for each cylinder of the engine.

Gasket – A material used between two surfaces to give a leakproof joint.

Glow plug – An electrical heating device fitted to a **diesel engine** to help the engine start from cold.

Head gasket (cylinder head gasket) – A gasket fitted to provide a leakproof seal between an engine's **cylinder block** and **cylinder head**.

Ignition coil – An electrical coil that generates the high voltage needed in a petrol engine **ignition system** to fire the **spark plugs**.

Ignition system – The electrical system that controls the spark used to ignite the petrol/air mixture in a petrol engine.

Ignition timing – A measure of the instant in the **cylinder** firing cycle at which the ignition spark (provided by the **spark plug**) happens in a petrol engine.

Inlet manifold – A ducting, usually made of metal or plastic, which directs the air, or fuel/air mixture into the engine's **cylinder head**.

Mixture – The fuel/air mixture burnt by an engine to produce power.

Oil filter – A renewable filter that removes dirt from engine oil.

Oxygen sensor (lambda sensor) – Provides information on the amount of oxygen in the exhaust gases. Used to enable the **engine management system** to control the petrol/air mixture.

Piston – Cylindrical component which slides in a close-fitting **cylinder**. The pistons in an engine compress the fuel/air mixture, transmit power to the **crankshaft** through the **connecting rods**, and push the burnt gases out through the exhaust **valves**.

Piston ring – A hardened metal ring that fits in a groove running around a **piston**. The piston ring ensures a gas-tight seal between the piston and the cylinder.

Radiator – A cooling device, usually positioned at the front of the car, through which the hot coolant is passed. As the car moves forward, the airflow cools the coolant in the radiator.

Rocker arm – A lever used in an engine's **valve**-operating mechanism which rocks on a pivot, with one end moved up and down by the **camshaft** and the other end operating a valve.

Spark plug – A device that provides the spark in a petrol engine's **combustion chamber** to ignite the petrol/air mixture.

Starter motor – An electric motor used to start the engine.

Stroke – The total distance travelled by a single piston in a **cylinder** when it moves from the bottom to the top of the cylinder.

Sump – The main reservoir for the engine oil. Bolted to the bottom of the engine.

Tappet - See **Cam follower**.

Timing belt (cam belt) – Toothed drivebelt, used to transmit drive from the **crankshaft** to the **camshaft**.

Thermostat – A device that helps the engine to warm up by stopping the coolant from flowing through the **radiator** until a certain temperature is reached.

Top Dead Centre (TDC) – The exact point when a piston is at the top of its **stroke**.

Turbocharger – A device that forces air into the engine. This pushes more fuel/air mixture into the engine and increases the engine's power.

Twin-cam – Abbreviation for twin overhead **camshafts** - see **DOHC**.

Valve – A device that opens and closes to stop or allow gas or liquid to flow.

Valve Clearance – The clearance between the top of a **valve** and the **camshaft**.

Valve lifter – See **Cam follower**.

16-valve – A term used to describe a four-cylinder engine with four **valves** in each cylinder, usually two exhaust and two inlet valves.

Vee-engine – An engine design where the **cylinders** are arranged in two rows, forming a 'V' when viewed from one end. For example, a V8 has two rows of four cylinders each.