

REELY

® Remote Control „HT-6“ 2.4 GHz

Item no. 1310037

CE

	Page
1. Introduction	4
2. Explanation of Symbols	4
3. Intended Use	5
4. Product Description	5
5. Scope of Delivery	6
6. Safety Information	6
a) General Information	6
b) Operation	7
7. Notes on Batteries and Rechargeable Batteries	8
8. Charging Rechargeable Batteries	8
9. Transmitter Controls	9
10. Setting Up the Transmitter	10
a) Inserting the Batteries	10
b) Switching on the Transmitter	11
c) Modifying the Throttle Function	13
d) Setting the Control Stick Length	14
11. Setting up the Receiver	15
a) Connecting the Receiver	15
b) LED Display	16
c) Mounting the Receiver	17
d) Installing the Servos	18
e) Checking the Servo Function	18
12. Programming the Remote Control	19
13. The System Setting Menu „System Setup“	20
a) Model Memory Selection „Model Select“	21
b) Model Name Setting „Model Name“	22
c) Model Type Selection „Type Select“	23
d) Copying Model Memory „Model Copy“	24
e) Deleting Model Memory „Model Reset“	25
f) Receiver Programming „RX Setup“	26
Digital Coding „AFHDS 2A“	27
Receiver Voltage „RX Battery“	28
Failsafe Setting „Failsafe“	29
Sensor List „Sensor List“	30
Servo Control Frequency „Servos Freq“	31

	Page
g) Operation as Trainer Transmitter „Trainer Mode“	32
h) Operation as Student Transmitter „Student Mode“	33
i) Control Stick Assignment „Sticks Mode“	34
j) Display Brightness „LCD Brightness“	35
k) Transmitter Software Version „Firmware Ver.“	36
l) Transmitter Software Update „Firmware Update“	37
m) Reset to Factory Settings „Factory Reset“	38
14. The Function Setting Menu „Functions Setup“	39
a) Servo Direction Setting „Reverse“	40
b) Servo End Deflection Setting „End Points“	41
c) Servo Control/Test „Display“	42
d) Encoder Assignment „Aux. Channels“	43
e) Basic Trim „Subtrim“	44
f) Dual Rate/Exponential Setting „Dual Rate/Exp.“	45
g) Throttle Curve Setting „Throttle Curve“	47
h) Pitch Curve Setting „Pitch Curve“	49
i) Swash Plate Servo Setting „Swash AFR“	51
j) Mixer Programming „Mix“	53
k) Delta Mixer „Elevon“	56
l) V-Tail Mixer „V Tail“	58
m) Gyro Sensitivity Setting „Gyroscope“	60
n) Switch Assignment „Switches Assign“	62
o) Throttle switch „Throttle Hold“	63
15. Remote Control Operation	64
16. Binding Function	65
17. Maintenance and Care	65
18. Declaration of Conformity (DOC)	66
19. Disposal	66
a) General Information	66
b) Batteries and Rechargeable Batteries	66
20. Troubleshooting	67
21. Technical Data	68
a) Transmitter	68
b) Receiver	68

1. Introduction

Dear Customer,

thank you for purchasing this product.

This product complies with the statutory national and European requirements.

To maintain this status and to ensure safe operation, you as the user must observe these operating instructions!



These operating instructions are part of this product. They contain important notes on commissioning and handling. Also consider this if you pass on the product to any third party.

Therefore, retain these operating instructions for reference!

All company names and product names are trademarks of their respective owners. All rights reserved.

If there are any technical questions, please contact: www.conrad.com/contact

2. Explanation of Symbols



The symbol with the exclamation mark points out particular dangers associated with handling, function or operation.



The „arrow“ symbol indicates special advice and operating information.

Operating Instructions for download

Use the link www.conrad.com/downloads (alternatively scan the QR code) to download the complete operating instructions (or new/current versions if available). Follow the instructions on the web page.



3. Intended Use

The 6-channel remote control „HT-6“ is solely designed for private use in the field of model construction and the operating times associated with it. This system is not suitable for industrial use, such as controlling machines or equipment.

Any use other than that described above can damage the product and involves additional risks such as short circuit, fire, electric shock, etc. The product must not be technically changed or converted! The safety information must be observed at all times!



Observe all safety information in these operating instructions. They contain important information on handling of the product.

You are solely responsible for the safe operation of your remote control and your model!

4. Product Description

The „HT-6“ remote control system is a radio remote control system ideally suited for model planes or helicopters.

The 6 proportional channels allow you to use the steering function and control function independently from each other. The remote control also features several mixing and memory functions needed for the different models. The settings of up to 20 different models can be saved in the remote control system.

In addition the remote control unit offers the option of calling different flight modes and thus set individual rudder deflections for specific flight phases such as take-off or landing.

Thanks to pioneering 2.4 GHz radio transmission with return channel, you can read current values, such as the receiver voltage or the quality of the radio control, comfortably at the display of your remote control transmitter. In connection with a receiver with I-BUS system and the corresponding sensor modules (each not enclosed), further measured values such as temperature, rotating speed or speed can be recorded and transmitted to the transmitter.

The LC display is easily readable and the easy-to-use buttons permit simple, quick and safe data input. Thanks to electronic trimming, the rudders are always in the correct position. The last set position is assumed automatically when the remote control is switched on!

The ergonomic casing can be held and operated comfortably and allows you to safely control the model.

The 2.4 GHz-receiver warrants best reception for secure signal transmission.

For operation, 4 AA/mignon batteries are required for the transmitter.

Where no flight controller with BEC switch is used, you also need 4 AA/mignon batteries for the receiver or 4 AA/mignon rechargeable batteries with the corresponding battery holder.

Alternatively, 4- or 5-cell NiMH receiver batteries can also be used with the switch cable.

5. Scope of Delivery

- Remote control transmitter
- Remote control receiver
- Binding plug
- Operating instructions

6. Safety Information



In case of damage caused by non-compliance with these operating instructions, the warranty/guarantee will expire. We do not assume any liability for consequential damage!

We do not assume any liability for property damage and personal injury caused by improper use or non-compliance with the safety instructions! In such cases the warranty/guarantee is voided.

Normal wear and tear in operation and damage due to accidents (like the receiver aerial being torn off, the receiver casing broken etc.) are excluded from the warranty.

Dear customer, these safety instructions are not only for the protection of the product but also for your own safety and that of other people. Therefore, read this chapter very carefully before taking the product into operation!

a) General Information

- The unauthorised conversion and/or modification of the product is prohibited for safety and approval reasons (CE).
- This product is not a toy and not suitable for children under 14 years of age.
- The product must not get damp or wet.
- Taking out private liability insurance is recommended. If you already have one, get some information on whether or not the operation of a radio-operated model is covered by your insurance.
- Do not connect the drive motor to electric models before the receiver system has been installed completely. This ensures that the drive motor does not start unintentionally.
- Do not leave packaging material unattended. It may become a dangerous toy for children.
- Please check the functional safety of your model and of the remote control system each time before you use the model. Watch out for visible damage such as defective plug connections or damaged cables. All movable parts on the model have to be running smoothly. However, there must be no tolerance or 'play' in the bearing.
- The operation and handling of RC models must be learned! If you have never controlled such a model, start especially carefully to get used to how it responds to the remote commands. Do be patient!
- Should questions arise that are not answered with the help of this operating manual, contact us (contact information, see chapter 1) or another expert.

b) Operation

- If you do not yet have sufficient knowledge on how to deal with remote-controlled models, please contact an experienced model sportsman or a model construction club.
- When putting the device into operation, always turn on the transmitter first. Then switch on the receiver in the model. Otherwise, the model might show unpredictable responses!
- Before operating the model, check whether the stationary model reacts as expected to the commands of the remote control.
- When you operate the model, always make sure that no parts of your body, other people or objects come within the dangerous range of the motors or any other rotating drive parts.
- Improper operation can cause serious damage to people and property! Always make sure that the model is in your line of sight and do not operate it at night.
- Only operate your model if your ability to respond is unrestricted. Fatigue or the influence of alcohol or medication can lead to wrong responses.
- Operate your model in an area where you do not endanger any persons, animals or objects. Only operate it on private sites or in places which are specifically designated for this purpose.
- In case of a fault stop operating your model straight away and remove the cause of malfunction before you continue to use the model.
- Do not operate your RC system during thunderstorms, beneath high-voltage power lines or in the proximity of radio masts.
- Never switch off the remote control (transmitter) while the model is in use. To switch off the model, always switch off the motor first, then switch off the receiver. Only then may the remote control be switched off.
- Protect the remote control from dampness and heavy dirt.
- Do not expose the remote control to direct sunlight or excessive heat for a long period of time.
- If the batteries in the remote control are low, the range decreases. If the receiver batteries or rechargeable battery in the receiver are low, the model will not respond correctly to the remote control.
If this is the case, stop flying immediately. Replace the batteries with new ones or recharge the rechargeable batteries.
- Do not take any risks when operating the product! Your own safety and that of your environment depends completely on your responsible use of the model.

7. Notes on Batteries and Rechargeable Batteries

- Keep batteries/rechargeable batteries out of the reach of children.
- Do not leave any batteries/rechargeable batteries lying around openly. There is a risk of batteries being swallowed by children or pets. If swallowed, consult a doctor immediately!
- Batteries/rechargeable batteries must never be short-circuited, disassembled or thrown into fire. There is a danger of explosion!
- Leaking or damaged batteries/rechargeable batteries can cause chemical burns to skin on contact; therefore, use suitable protective gloves.
- Do not recharge normal batteries. There is a risk of fire and explosion! Charge only rechargeable batteries intended for this; use suitable chargers.
- Always observe correct polarity (positive/+ and negative/-) when inserting the batteries/rechargeable batteries.
- If the device is not used for an extended period of time (e.g. storage), remove the inserted batteries/rechargeable batteries from the remote control and the car to avoid damage from leaking batteries/rechargeable batteries.
- Recharge the rechargeable batteries about every 3 months. Otherwise, so-called deep discharge may result, rendering the rechargeable batteries useless.
- Always replace the entire set of batteries or rechargeable batteries. Never mix fully charged batteries/rechargeable batteries with partially discharged ones. Always use batteries or rechargeable batteries of the same type and manufacturer.
- Never mix batteries and rechargeable batteries!
- For reasons of operational safety, only use batteries and rechargeable batteries for the remote control transmitter.

8. Charging Rechargeable Batteries

If you use rechargeable batteries for power supply of the receiver, they are usually flat at delivery and must be charged.



Note:

Before a rechargeable battery reaches maximum capacity, several complete discharge and charge cycles are necessary.

Always discharge the rechargeable battery at regular intervals, since charging a „half-full“ rechargeable battery several times can cause a so-called lazy battery effect. This means that the rechargeable battery loses capacity. It no longer provides all of its stored energy, and the operating time of the model is reduced.

If you use several rechargeable batteries, purchasing a high-quality charger may be worthwhile. Such a charger usually has a quick-charging feature.

9. Transmitter Controls

Front:

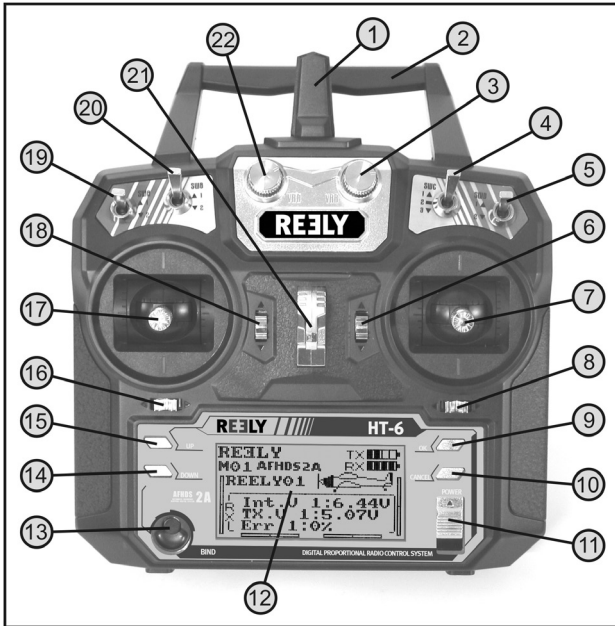

Figure 1

- | | |
|--|--|
| 1 Transmitter aerial | 13 Binding button |
| 2 Carry handle with integrated second transmitter aerial | 14 „DOWN“ button |
| 3 Rotary encoder „VRB“ | 15 „UP“ button |
| 4 Toggle switch „SWC“ | 16 Trim button for rudder/tail function (in mode II)* |
| 5 Toggle switch „SWD“ | 17 Control stick for rudder/tail and throttle/pitch function (in mode II)* |
| 6 Trim button for elevator/nod function (in mode II)* | 18 Trim button for throttle/pitch function (in mode II)* |
| 7 Control stick for elevator/nod and aileron/roll function (in mode II)* | 19 Toggle switch „SWA“ |
| 8 Trim button for aileron/roll function (in mode II)* | 20 Toggle switch „SWB“ |
| 9 „OK“ button | 21 Eyelet for shoulder belt |
| 10 „CANCEL“ button | 22 Rotary encoder „VRA“ |
| 11 On/off switch | |
| 12 LC display | |

* Further information for mode setting can be found in the system setting menu in the menu item „Sticks mode“.

Rear:

- 23 Trainer/student socket
- 24 Battery compartment lid



Figure 2

10. Setting Up the Transmitter



In the further course of these instructions, figures in the text always refer to the adjacent figure or the figures within the section. References to other figures are indicated with the corresponding figure number.

a) Inserting the Batteries

For the power supply of the transmitter you will need 4 alkaline batteries of the size AA/mignon.

Proceed as follows to insert the batteries:

The battery compartment lid (1) is located on the back of the transmitter. Press the corrugated area (2) and push off the lid downwards.

Ensure that the polarity is correct when inserting the 4 batteries. A corresponding note (3) is located on the bottom of the battery compartment.

Then slide the lid of the battery compartment back on from the bottom until the locking mechanism engages.

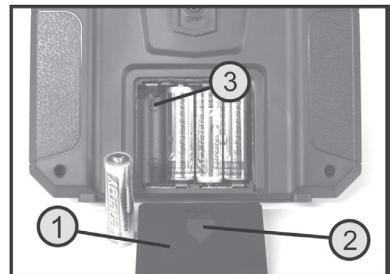

Figure 3

b) Switching on the Transmitter

After you have inserted four new batteries, check the position of the toggle switches. All switches must be in the front position.

The control stick for the elevator/nod and aileron/roll function (see figure 1, item 7) must be in the middle position. The control stick for the rudder/tail and throttle/pitch functions (see figure 1, item 17) must be in the middle position as well or must be pushed into the bottom-most position (motor off).

Now switch on the transmitter using the on/off switch (see fig. 1, item 11).

First, you will hear three signal sounds in increasing pitch and the operating display with the currently set model appears in the backlit display.

The backlighting is deactivated automatically about 20 seconds after activation or the last button operation. If no operating element is operated within 60 s with the plant on, the plant will emit short signal sounds as warning note.

The operating display consists of the following elements:

- 1 Manufacturer logo
- 2 Digital encoding
- 3 Memory display
- 4 Model name display
- 5 Throttle/pitch trimming display (in Mode II)*
- 6 Rudder/tail trimming display (in Mode II)*
- 7 Aileron/roll trimming display (in Mode II)*
- 8 Elevator/nod trimming display (in Mode II)*
- 9 Battery symbol for transmitter voltage supply
- 10 Battery symbol for receiver voltage supply
- 11 Model type figure
- 12 Display of the receiver voltage
- 13 Display of the transmitter voltage
- 14 Display of the defectively transmitted transmitter

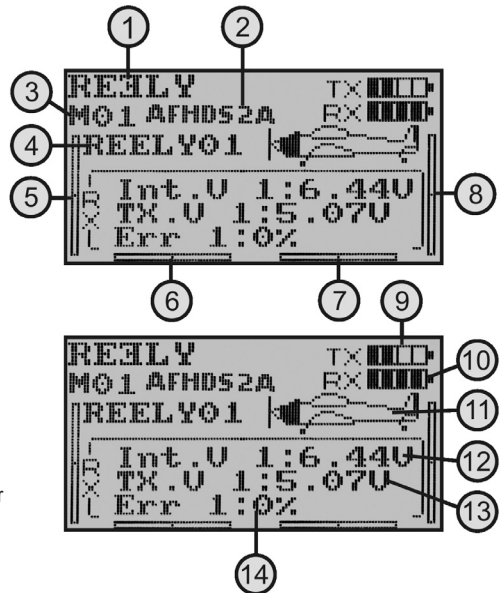

Figure 4

* Further information for mode setting can be found in the system setting menu in the menu item „Sticks mode“.



The operating instructions in figure 4 appear completely only if the receiver system is in operation. Otherwise, e.g. the values for receiver voltage or signal quality are not displayed.



If one of the four toggle switches (see figure 1, items 4, 5, 19 and 20) is not in the front position, and if the control stick for the throttle/pitch function is not in the bottom position, warning sounds are emitted at activation and the corresponding note is displayed.

In this case, the affected switches and the control stick must be put in the required position. The display then switches to the operating display and the warning sounds go out.

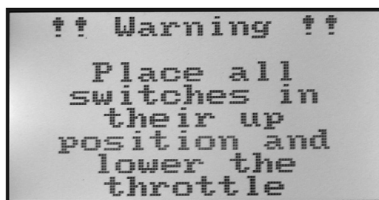

Figure 5



Important!

If the power supply is not sufficient for correct transmitter operation anymore, the battery icon will flash at a voltage of less than 4.2 V and the transmitter emits acoustic warning sounds at regular intervals. The model should then no longer be operated.

When the voltage drops below 4.0 V, the transmitter emits alarm sounds without interrupting. In this case, operation of the model must be ceased as quickly as possible, since the model may otherwise be lost!

Insert new batteries for further operation of the transmitter.

c) Modifying the Throttle Function

Ex works, your remote control „HT-6“ is configured so that the control lever for the throttle/pitch function is on the left. This is the most common configuration in Europe. If you prefer to have the throttle/pitch function on the right as opposed to the left stick, you have the option of swapping the two stick units with each other.

To make the necessary changes, some experience with remote control transmitters is required. Therefore you should consult an experienced model maker or a model construction club if you do not feel capable of undertaking the procedures described in the following.

- Remove the transmitter batteries.
- Unscrew the four screws by means of a Phillips-tip screwdriver from the rear panel of the transmitter and lift the rear panel carefully towards the left.
- On demand, you can disconnect the supply lines of the battery box and the teacher/student socket (1) at the main PCB.
- For this, loosen the four screws at the control stick units and swap the two units (fig. 6A, item 2). You need to turn the control stick units by 180° each so that the connections of the control stick potentiometers (3) are aligned to the inside again (see fig. 6B).
- Screw on the control stick units again and check the mechanical function of the control sticks.
- Connect the battery box and the teacher/student box to the main PCB.
- Attach the transmitter back wall again and turn in the four attachment screws again.

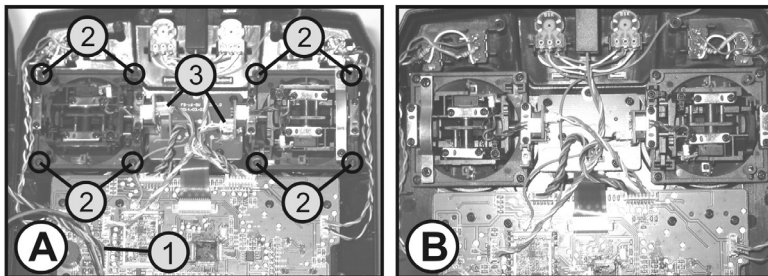

Figure 6



The electronic modification of the throttle function is done later in the System setting menu under „Sticks mode“.

d) Setting the Control Stick Length

You can adjust the length of the control sticks, depending on your steering habits.

To do so simply hold the bottom part of the grip (1) and turn the upper part (2) up anti-clockwise.

You can now set the length of the control stick by turning the bottom part of the grip.

Finally, tighten the upper part of the grip back up.

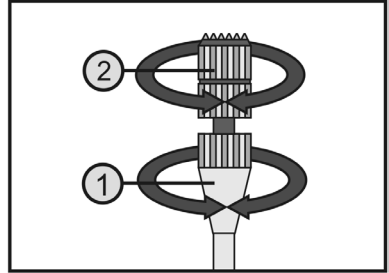

Figure 7

11. Setting up the Receiver

a) Receiver Connection

On its right hand side, the receiver (see figure 8, item 1) offers the option of connecting up to 6 servos with JR or Futaba plug connectors.

The receiver battery or a battery box is connected to a switch cable either on a free slot or at the top-most slot (B/VCC).

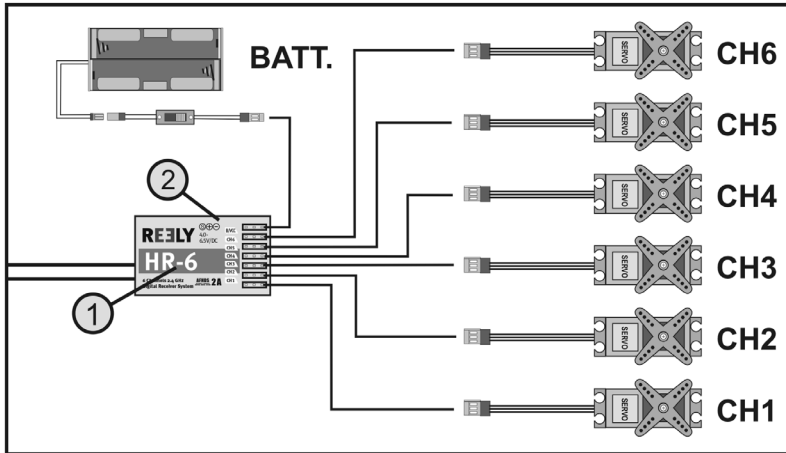

Figure 8



When connecting servos and speed controllers, always make sure of correct polarity of the plug connectors. The impulse line of the servos (depending on manufacturer yellow, white or orange) must be connected to the left (inner) one of the three adjacent plug-in contacts. The plug contact for the negative line (black or brown, depending on the manufacturer) must be connected to the right (outer) pin contact.

The receiver outputs are assigned as follows:

Channel	Output	Helicopter	Motor model plane
1	CH1	Roll servo	Aileron servo
2	CH2	Pitch servo	Elevator servo
3	CH3	Throttle servo or flight controller	Throttle servo or flight controller
4	CH4	Tail servo/gyro	Rudder servo
5	CH5	Gyro sensitivity	Additional channel 5
6	CH6	Pitch servo	Additional channel 6
-	B/VCC	Battery connection*	Battery connection*

* Electric models with an electronic flight controller only require a separate rechargeable receiver battery if the flight controller used does not have a BEC circuit. For further information, refer to the technical documents of the controller.

Channels 5 and 6 can be assigned differently depending on model. There also is the option of operating two servos via a V-cable at a receiver output.

For a possible setup or distribution of the control channel, see the adjacent sketches in figure 9.

If a model is equipped, e.g. with two aileron servos, the second servo can be connected to a receiver output that has not been assigned yet. The control is then performed via one of the three freely programming mixers.

For more information on the servo connection and the mixing functions, see the following chapters (programming of the remote control transmitter) in the respective function.

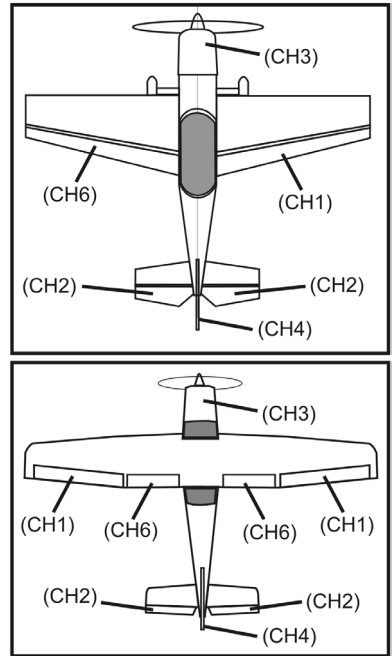

Figure 9



Important!

It is recommended to use a pair of tweezers or long-nosed pliers to disconnect the connection. To prevent cable breaks, you should always pull on the plastic casing of the plug to disconnect the connection. Never pull on the cables.

b) LED Display

The receiver has an LED display that serves mainly as an indicator for the receiver condition on one side (see figure 8, item 2).

The LED is lit only when the transmitter is on and bound to the receiver in operation of the receiver. If the transmitter does not recognise any valid transmitter signal, the LED flashes. More information on the transmitter binding can be taken from chapter: Binding Function.

c) Installing the Receiver

Installation of the receiver depends on the model. For this reason, you should always follow the recommendations of the model manufacturer regarding the installation. Regardless of the model, you should always try to install the receiver so that it is protected from dust, dirt, moisture, heat and vibration in the best possible way.

Keep enough distance from motors and electronic flight or speed controllers. Metal or carbon parts have a shielding effect and thus may considerably impair reception. In this case, it is sensible to relocate the aerial outwards through bores in the fuselage.

Two-sided adhesive foam (servo tape) or rubber rings that hold the foam-wrapped receiver securely in place are suitable for fastening.



Caution, important!

The receiver has two separate HF-receiver parts that are equipped with a receiver aerial (1 and 2) each.

To achieve the maximum possible reception line, the two aerials must be placed at a 90°-angle to each other.

It is not relevant if one aerial is placed to the right and the other up or one to the left and the other down. It is only important that the two aerials are at a 90° angle to each other.

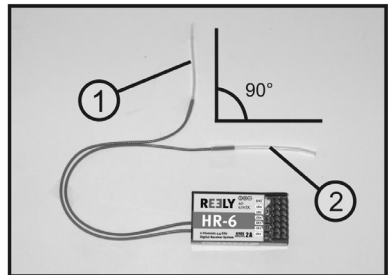

Figure 10



Attention!

The aerial wire lengths are determined precisely.

For this reason, you must not roll up the aerial wires, place them in a loop or cut them off. This would decrease the range significantly and thus pose a considerable safety risk.

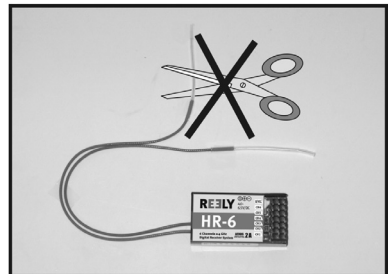

Figure 11

Route the aerial wires out of the mode through an opening in the fuselage if possible. For models with a carbon fuselage, the aerial must be placed to the outside.

d) Mounting the Servos

The installation of a servo (1) always depends on the particular model used. Detailed information on this can be found in the construction documents of the model.

Generally, however, try screwing in the servos in a vibration-dampened manner. This is why rubber bushings (2) with metal sleeves (3) are usually included with the servos.

When servos are obstructed, the servos cannot assume the required positions. This causes higher power consumption and the model cannot be controlled properly.

The linkages therefore must work as smoothly as possible without having any play in the bearings or deflections.

Before installing the servo lever, take the transmitter and then the receiver into operation and check the trim at the remote control transmitter for correct middle position (see following chapter).

Then always mount the servo stick at a 90° angle to the linkage rods (see figure 9, sketch A).

The servo lever is at an angle to the linkage rod (see figure 9, sketch B), the control paths of the two control directions will be unequal.

A slight mechanical inclination due to interlock of the servo levers may be corrected with the trim later.

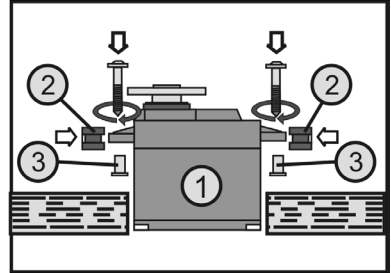

Figure 12

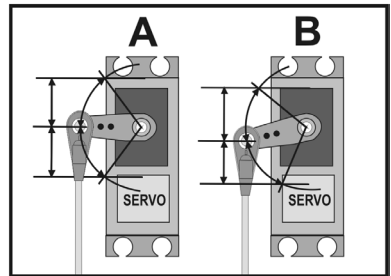

Figure 13

e) Checking the Servo Function

To run a test, connect the servos used to the receiver. Pay attention to the assignment of the receiver outputs as described above.

Take the remote control into operation, then the receiver. If attached correctly, the servos should react to movement of the control sticks at outputs 1 - 4. The servos at the outlets 5 and 6 react depending on the models programmed to the transmitter and/or the activated switches and controllers. Further information on transmitter programming can be taken from the following chapter: Programming the Remote Control.



Caution, important!

Always switch on the transmitter first, then the receiver. When you switch off the devices, always switch off the receiver first, then the transmitter.

Never switch off the remote control as long as the receiver is in operation. This can lead to unexpected reactions by the model!

12. Programming the Remote Control

Your remote control offers a „System setup“ menu for best adjustment to your model and a „Functions setup“ menu with different menu items that have many subordinated settings as well.

Depending on the model type (helicopter or plane model) set in the system menu, the function menu setting options will differ.

The changes of the respective settings are made with the four programming buttons (also see figure 1, items 9, 10, 14 and 15).

The settings are permanently saved and are retained even when changing the batteries.

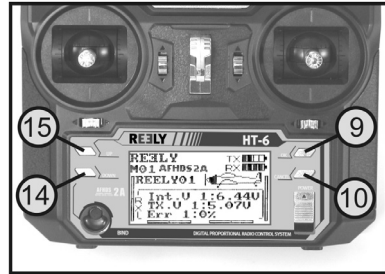

Figure 14

The functions of the operating elements:

- **„OK“ button**

To call the programming menus, briefly push the button „OK“ with the transmitter on. The displayed operating display switches to the menu display and the transmitter switches to programming mode. This button can also activate selected settings. If the button is pushed or longer, the factory settings stored in the menu item are called.

- **„CANCEL“ button**

This button allows you to leave the currently selected menu or submenu again. Every brief push of this button takes you a step back until you reach the operational display. If the button is kept pushed for a while, the changed set values are stored.

- **„UP“ and „DOWN“ buttons**

The two buttons can be used to select the desired menu/submenu or change set values.



The transmitter emits a short signal sound for each permissible push of a button.

13. The System Setting Menu „System Setup“

The basic settings of the remote control transmitter are made in the system setup menu first. These settings are not referred to individual models. The specific settings of the individual models are only made afterwards in the function setting menu (see chapter 14).

To get to the system settings menu, push the button „OK“ with the transmitter switched on. The operating display in the display switches to the menu display. The selection window around the remote control icon shows that you can call the „System Setup“ menu in this setting.

Briefly push the button „OK“ again to get to the system settings menu.

The first 6 menu items of the system setting menu are now displayed.

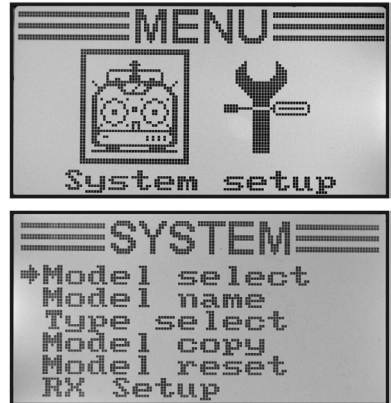

Figure 15

The following setting functions are available for you in the system setting menu:

Function	Display
Model memory selection	„Model select“
Model name settings	„Model name“
Model type selection	„Type select“
Copying model memory	„Model copy“
Deleting model memory	„Model reset“
Receiver programming	„RX Setup“
Operation as a trainer transmitter	„Trainer mode“
Operation as a student transmitter	„Student mode“
Control stick assignment	„Sticks mode“
Display brightness	„LCD brightness“
Transmitter software version	„Firmware ver.“
Transmitter software update	„Firmware update“
Factory reset	„Factory reset“

a) Model Memory Selection „Model Select“

The remote control system has 20 model memories which allow you to save the data for your respective models independently of one another. Therefore, it is required to set the associated model memory in the transmitter before operating a specific model.

Setting the model memory:

- Switch on the transmitter and call the system setting menu. The top menu item „Model select“ is marked by the cursor arrow.
- Briefly push the button „OK“ to activate the menu item.
The display shows the currently activated model memory. Additionally, the model name and a model type figure are displayed.
- Push the buttons „UP“ or „DOWN“ to select the desired model memory 1 - 20.
- Keep the button „CANCEL“ pushed for a longer period to activate the desired model memory. The display then shows the system setup menu again.
- Push the button „CANCEL“ repeatedly until you return to the operating display and check if the desired model memory is set.

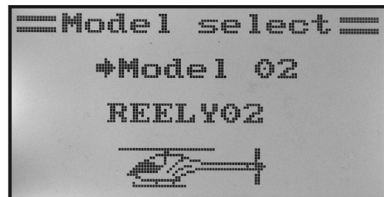
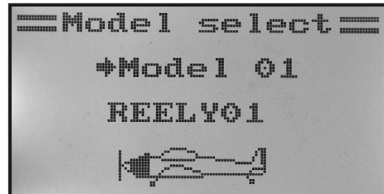
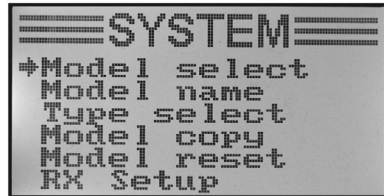

Figure 16

- ➔ If you want to switch the model memory even though the receiver is still on, the display shows a warning note that the receiver must be switched off before a model memory change.

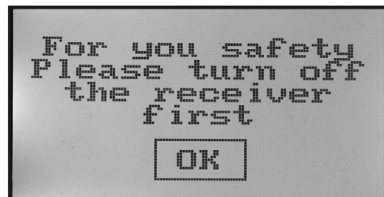

Figure 17

b) Model Name Setting „Model Name“

In order to be able to discern between model memories more easily it makes sense to give the memories the name of the corresponding models. The name can consist of a combination of up to 8 letters, numbers or characters.



Caution, important!

You can always change only the name of the model memory that is active at the moment. If you want to change the name of another model memory, you need to call and activate the desired model memory first.

Setting the model name:

- Switch on the transmitter and call the system setting menu.
- Move the cursor arrow to the menu item „Model name“ with the two buttons „UP“ and „DOWN“.
- Briefly push the button „OK“ to activate the menu item.

The display shows the currently set model memory with the model name. The first letter in the name is already backlit back and can be set.

- Push the buttons „UP“ or „DOWN“ to select the desired letter now. The arrow pointing to the right at the lower display edge indicates that the remaining letters and special characters are available on a second display page.
- To switch to the second letter, briefly push the button „OK“. The second letter then gets a black background. If you push the button „OK“ and hold it, the model name set ex works is called.

The second letter is set according to the same pattern as the first one.

- Repeat the above procedure until the desired model name has been programmed.
- Keep the button „CANCEL“ pushed for a longer period to save the set model name. The display then shows the system setup menu again.
- Push the button „CANCEL“ repeatedly until you return to the operating display and check if the desired model name is set correctly.

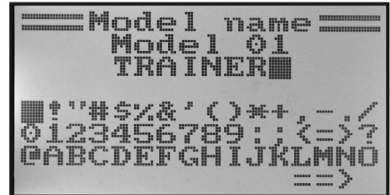
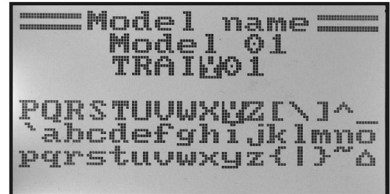
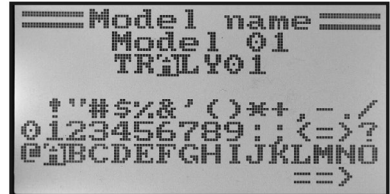
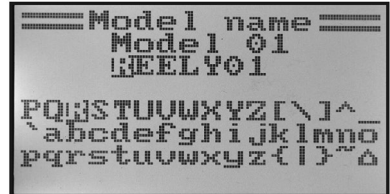
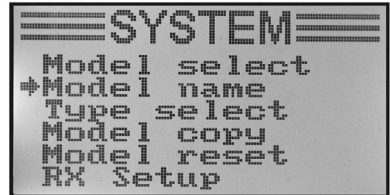

Figure 18

c) Model Type Selection „Type Select“

As there are different functions available for each of the respective model types, such as mixers or switching functions, it is necessary to enter the right model type during programming. You can pick between model planes „Airplane or glider“ and helicopter models „Helicopter“.

Among the helicopter models, the following versions are also available with different swash plate linkages:

„Fixed pitch“:

Select these settings in speed-controlled model helicopters in which the angle of attack of the main rotor blades cannot be adjusted.

„Variable pitch“:

Choose this setting for helicopters that use a separate servo each for rolling, nodding and pitch functions.

„Swash 90°, 120° or 140“:

Select this setting when the swash plate for your model helicopter is controlled with 3 servos and the linkage points at the swash plate are offset against each other by 90°, 120° or 140°. Depending on angle of the linkage points, different mixing ratios of the three swash plate servos are required that the transmitter will be considered automatically then. On demand, you can find more information on the swash plate linkage in the documents of your model helicopter.

Selection of the model type:

- Switch on the transmitter and call the system setting menu.
- Move the cursor arrow to the menu item „Type select“ with the two buttons „UP“ and „DOWN“.
- Briefly push the button „OK“ to activate the menu item.

The display shows the currently set model memory with the model name and model type. Additionally, the model type is displayed at the bottom display edge with a figure that is later shown in the operating display as well.

- Push the buttons „UP“ or „DOWN“ to select the desired model type now.
- Keep the button „CANCEL“ pushed for a longer period to save the set model type. The display then shows the system setup menu again.
- Push the button „CANCEL“ repeatedly until you return to the operating display and check if the correct figure is displayed.

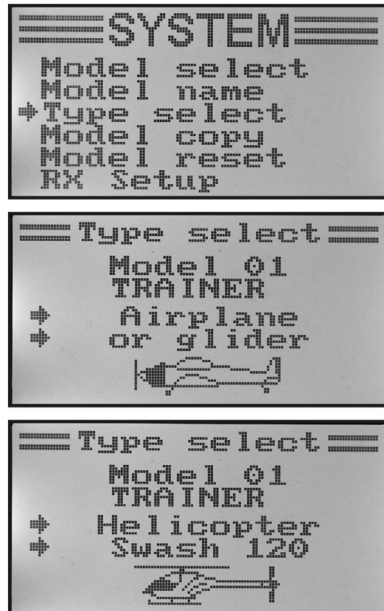

Figure 19

d) Copying Model Memory „Model Copy“

For simple programming of the system you have the option of copying data from one model memory to another. This helps to easily transfer basic settings and mixer between similar models and you only need to adjust the settings values to the new model.

Copying model data into another model memory:

- Switch on the transmitter and call the system setting menu.
- Move the cursor arrow to the menu item „Model copy“ with the two buttons „UP“ and „DOWN“.
- Briefly push the button „OK“ to activate the menu item.

The display shows two model memories with the respective activated model names and the associated model type figure. The model memory above is the data source and the model memory below is the target memory.

- Use the buttons „UP“ or „DOWN“ to select the model memory from which the data are to be copied.
- Briefly push the button „OK“ to switch to the target memory.
- Use the buttons „UP“ or „DOWN“ to select the model memory into which the data are to be copied.
- Push the button „OK“ for longer to start copying. The display now shows a safety prompt.
- Pushing the buttons „UP“ or „DOWN“ switches the cursor arrow from „No“ to „Yes“. Push the button „OK“ again to copy. The display then shows the system setup menu again.
- Push the button „CANCEL“ repeatedly until you get back to the operating display.

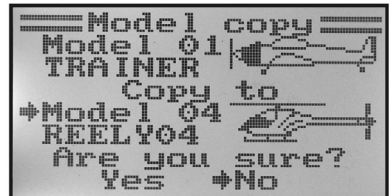
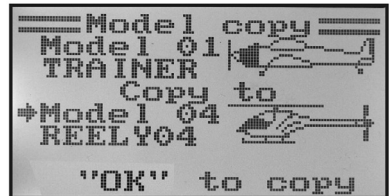
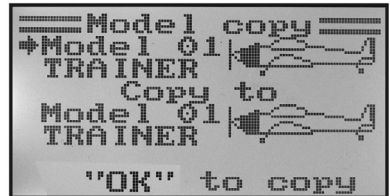
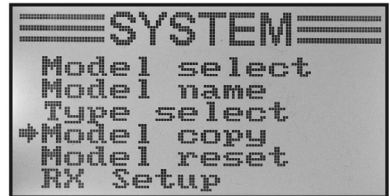

Figure 20



Since the model name is also copied, call the model memory into which you copied the data right after copying and enter the name of the new model there at once. This avoids undesired mistakes among the model memories.

e) Deleting Model Memory „Model Reset“

To remove any present and undesired settings before programming a new model, you can delete individual model memories targetedly and thus reset them to factory settings.

Deleting model memory:

- Switch on the transmitter and call the system setting menu.
- Move the cursor arrow to the menu item „Model reset“ with the two buttons „UP“ and „DOWN“.
- Briefly push the button „OK“ to activate the menu item.

The display shows the currently set model memory with the model name and model figure.

- Use the buttons „UP“ or „DOWN“ to select the model memory to be reset to factory parameters.
- After pushing the button „OK“, a safety prompt appears.
- Pushing the buttons „UP“ or „DOWN“ switches the cursor arrow from „No“ to „Yes“. Push the button „OK“ again to delete the model memory. The display then shows the system setup menu again.
- Push the button „CANCEL“ repeatedly until you get back to the operating display.

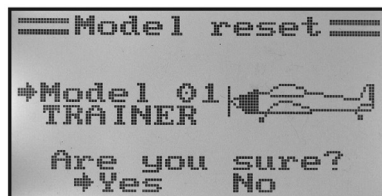
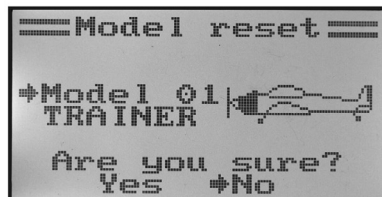
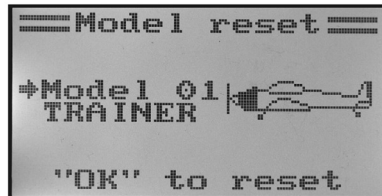
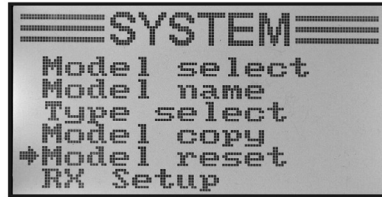

Figure 21

f) Receiver Programming „RX Setup“

The remote control „HT-6“ offers the option of setting different receiver parameters or display the measured values. The function of the displays and settings depends on the respective receiver used and the connected sensors.

Since the enclosed receiver does not support connection of external sensors, these instructions only deal with the settings that are relevant for the enclosed receiver. More information on sensor connection can be taken from the optional I-bus receivers.

The menu receiver programming is structured in the following submenus:

Function	Displayanzeige
Digital encoding	„AFHDS 2A“
Receiver voltage	„RX Battery“
Failsafe setting	„Failsafe“
Sensor list *	„Sensor list“
Sensor selection list *	„Choose sensors“
Speed and distance *	„Speed-distance“
Data bus setting *	„i-BUS Setup“
Servo control frequency	„Servos Freq“

* The marked menu items are mostly relevant for using an I-BUS receiver with the corresponding sensors. More detailed notes on programming can be taken from the operating instructions of the I-BUS receiver or sensors.

Digital coding „AFHDS 2A“

The remote control transmitter enables you to control receivers with the digital code „AFHDS 2A“ and „AFHDS“. Ex works, the transmitter is set to the enclosed „AFHDS 2A“-encoded receiver.

If you want to operate a REELY receiver with the digital code „AFHDS“, the transmitter must be switched first and then the receiver must be bound to the transmitter. More information on binding of transmitter and receiver can be taken from chapter 16: Binding Function.

To switch the digital code at the transmitter, proceed as follows:

- Call the „RX Setup“ menu.
- The menu item „AFHDS 2A“ is already selected and can be activated with the button „OK“.
- The buttons „UP“ or „DOWN“ switch the digital encoding „AFHDS 2A“ off. The display shows „Off“.
- Pushing the button „OK“ saves the setting and the display shows the digital code „AFHDS“.
- Push the button „CANCEL“ repeatedly until you get back to the operating display.
- Then perform binding.
- Switch back to „AFHDS 2A“ according to the same principle as described above.

If the transmitter works with the digital code „AFHDS“, the menu „RX Setup“ only shows the digital code as a setting option. Only when the transmitter code has been set back to „AFHDS 2A“ will the menu „RX setup“ have all menu items available again.

```
=====SYSTEM=====
Model select
Model name
Type select
Model copy
Model reset
➔RX Setup
```

```
=====RX Setup=====
➔AFHDS 2A
RX Battery
Failsafe
Sensors list
Choose sensors
Speed-distance
```

```
=====RF Standard=====
AFHDS 2A
On
```

```
=====RF Standard=====
AFHDS 2A
Off
```

```
=====RX Setup=====
➔AFHDS
```

Figure 22

Receiver voltage „RX battery“

Depending on the receiver voltage supply used, this menu can be used to set the voltage values where the remote control visually and acoustically displays threatening deep discharge.

To set the receiver voltages, proceed as follows:

- Call the „RX Setup“ menu.
- Use the buttons „UP“ or „DOWN“ to select the menu item „RX Battery“ and activate it with the button „OK“.
- Use the buttons „UP“ and „DOWN“ to set the lowest voltage value „Low“ that is already selected with the cursor arrow. If the button „OK“ is pushed and held, the factory parameters are called.
- Briefly push the button „OK“ to switch to the next-higher voltage value „Alarm“. The setting is made with buttons „UP“ and „DOWN“ again.
- Use the button „OK“ to switch to the voltage value at fully charged rechargeable battery „High“ and again set the required value with the buttons „UP“ or „DOWN“.
- Keep the button „CANCEL“ pushed for a longer period to save the set voltage values. The display then shows the system setup menu again.
- Push the button „CANCEL“ repeatedly until you get back to the operating display.



Since the adjustable voltage values depend on each other, it may be required to increase the voltage value for a fully charged rechargeable battery first, to then be able to enter higher alarm values as well.

If the set thresholds are undercut, the battery icon for the receiver battery will flash at operation of the remote control and the remote control transmitter will make warning or alarm sounds.

```
====RX Setup====
AFHDS 2A
+RX Battery
Failsafe
Sensors list
Choose sensors
Speed-distance
```

```
====RX Battery====

+Low      4.00U
Alarm    4.20U
High     5.00U
```

```
====RX Battery====

+Low      4.10U
Alarm    4.20U
High     5.00U
```

```
====RX Battery====

Low      4.10U
+Alarm   4.30U
High     5.00U
```

```
====RX Battery====

Low      4.10U
Alarm    4.30U
+High    4.80U
```

Figure 23

Failsafe setting „Failsafe“

The remote control has the option of automatically moving the servos to a specific position at impairment of the reception signal. This way, the drive motor can be switched off, e.g. in an electrical gliding model that is outside of the transmitter range, and circling can be started.

Proceed as follows to set the fail safe values for all six control channels:

- Call the „RX Setup“ menu.
- Use the buttons „UP“ or „DOWN“ to select the menu item „Failsafe“ and activate it with the button „OK“. Channel 1 is already selected and can be set.
- Briefly push the button „OK“ to call the set values for channel 1. The current activation condition for channel 1 is displayed.
- Use the buttons „UP“ or „DOWN“ to switch the activation condition from „OFF“ to „ON“ or vice versa.
- If the function is switched on, move the control stick for channel 1 to the desired failsafe position and push the button „CANCEL“ a little longer.
- The display switches back to the channel overview and displays the percentage set value for channel 1.

 If you keep the button „OK“ pushed, the factory setting is called and the fail safe function is switched off for all six channels.

- You can now use the buttons „UP“ and „DOWN“ to select further channels and set them according to the same principle.
- When you have set the desired value for all channels, push the button „CANCEL“ until you return to the operating display.
- Switch the transmitter off for test purposes and check if all servos move to the fail safe position desired by you

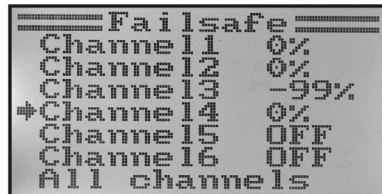
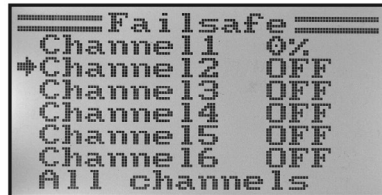
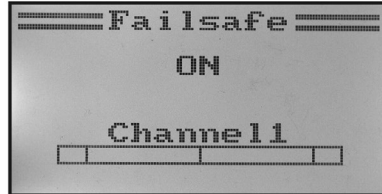
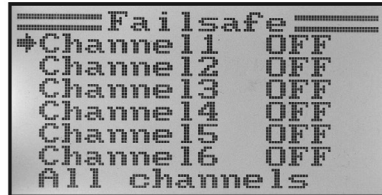
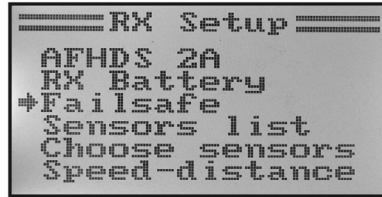

Figure 24

Sensor list „Sensor list“

The sensor list shows the connected sensors. In case of the enclosed receiver, only the receiver voltage „Int.V“, the transmitter voltage „TX.V“ and the error rate of the receiver signal „Err“ is displayed. The larger the distance between the transmitter and the receiver, and the worse the quality of the receiver signal, the higher the percentage of the defectively received data.

Since a moving model will have a continually changing alignment of the receiver aerials, the strong fluctuation at the error display is perfectly normal.



If several sensors are connected to one I-BUS receiver, these sensors are displayed in this menu.

```
=====RX Setup=====
AFHDS 2A
RX Battery
Failsafe
+Sensors list
Choose sensors
Speed-distance
```

```
=====Sensors list=====
Int.V 1 6.46V
TX.V 1 5.73V
Err 1 0%
```

Figure 25

Servo control frequency „Servos freq“

Analogue servos are supplied with a control impulse 50 times per second by the receiver. Digital servos in contrast can be controlled much more often. This enables them, among others, to develop high adjustment and holding forces and to move to the specified positions extremely fast. The control frequency a servo can bear can be taken from the technical data sheets of the individual servos.

To set the servo control frequency, proceed as follows:

- Call the „RX Setup“ menu.
- Use the buttons „UP“ or „DOWN“ to select the menu item „Servos Freq“ and activate it with the button „OK“.
- Use the buttons „UP“ or „DOWN“ to set the desired servo control frequency. If the button „OK“ is pushed and held, the factory parameters are called.
- Keep the button „CANCEL“ pushed for a longer period to save the set servo control frequency. The display then shows the „RX setup“ menu again.
- Push the button „CANCEL“ repeatedly until you get back to the operating display.



Caution, important!

When using analogue servos, the servo control frequency must not exceed 50 Hz, since the servos are otherwise destroyed. If you operate only digital servos at the receiver, the value to be set is according to the maximum value of the slowest servo, since the set value is effective for all receiver outputs.

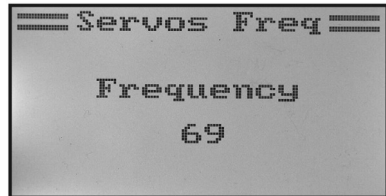
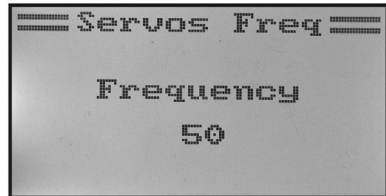
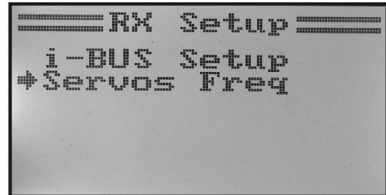

Figure 26

g) Operation as Teaching Transmitter „Trainer Mode“

For safe and comfortable model flight training, the remote control system offers a plug-in socket for a trainer-student cable (see figure 2, item 23). An optional cable permits connecting a second remote control type „HT-6“ (or alternatively „HT-4“) to your transmitter. When using two „HT-6“ transmitters, one of them must be configured as the teaching transmitter and the other as the student transmitter (see following menu item). The flight trainer can use a freely selectable toggle switch to switch between the control stick signals of the trainer and student transmitter.

Configuration as trainer transmitter:

- Switch on the transmitter and call the system setting menu.
- Move the cursor arrow to the menu item „Trainer mode“ with the two buttons „UP“ and „DOWN“.
- Briefly push the button „OK“ to activate the menu item.

The display shows the indication Mode, Switch and, depending on the trainer/student switch, „Engaged“ (connected to the student transmitter) or „not engaged“ (not connected).

- Push the buttons „UP“ or „DOWN“ to select whether to activate the trainer function and the transmitter „ON“ or to deactivate it „OFF“.
- Briefly push the button „OK“ to switch to the switch selection.
- By pushing the buttons „UP“ or „DOWN“, you can now choose which switch you want to use to switch between teaching and student transmitter. Then confirm the selected switch and check if the display changes between „Engaged“ and „Not engaged“.
- Keep the button „CANCEL“ pushed for a longer period to save the settings. The display then shows the system setup menu again.
- Push the button „CANCEL“ repeatedly until you get back to the operating display.

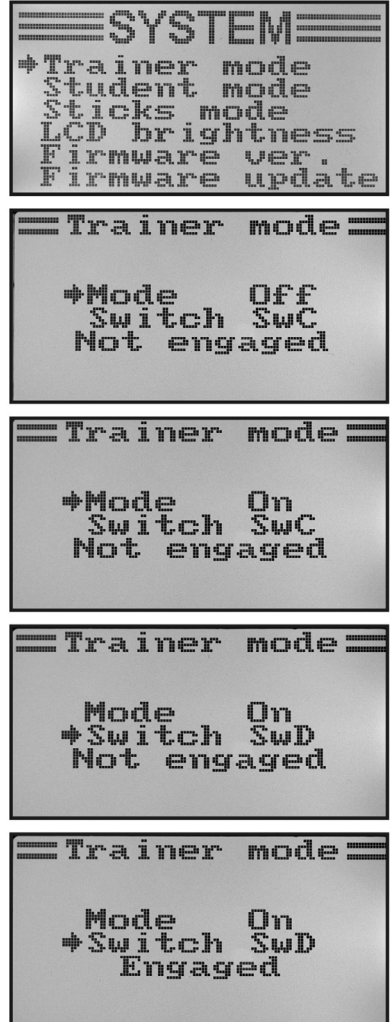

Figure 27

h) Operation as Student Transmitter „Student Mode“

When configuring as a student transmitter, the signals of the control sticks and the control encoder for channels 5 and 6 are sent directly to the teacher/student socket at the rear independently of the set mode and transferred to the teaching transmitter via the connection cable.

If the student transmitter mode is not activated, the six control signals are branched off at the teacher/student socket according to the model type set with all programmed settings and mixers. When operating the remote control with a flight simulator interface, we recommend also operating the remote control in student mode. The mixers or settings required for the virtual models are then available in the simulator software.

Configuration as student transmitter:

- Switch on the transmitter and call the system setting menu.
- Move the cursor arrow to the menu item „Student mode“ with the two buttons „UP“ and „DOWN“.
- Briefly push the button „OK“ to activate the menu item.

The display shows the notice that all transmitter settings are invalid in the student configuration and the control stick settings are transferred right to the trainer transmitter.

- After pushing the button „OK“, a safety prompt appears.
- Pushing the buttons „UP“ or „DOWN“ switches the cursor arrow from „No“ to „Yes“. Push the button „OK“ again to activate student mode. The display then shows the system setup menu again.
- Push the button „CANCEL“ repeatedly until you get back to the operating display. The student mode is displayed visually in the operating display by an additional „S“.
- When calling the student menu again, the configuration can be terminated as student transmitter by pushing the button „OK“.



Important!

Coordinate the trimming of the student transmitter so that it matches the one of the trainer transmitter. The rudder of the model plane or the swash plate and the tail rotor control must have precisely the same neutral position after switching from trainer to student transmitter when the two systems do not have deflected control sticks.

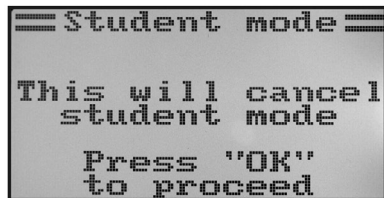
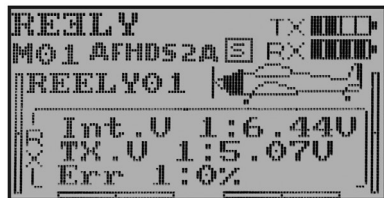
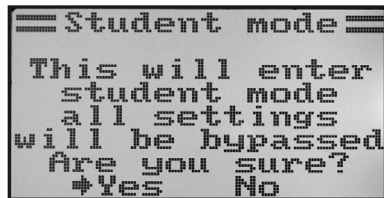
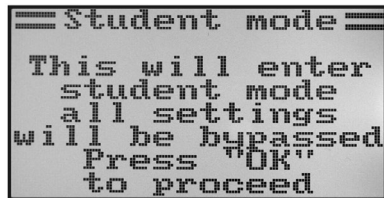
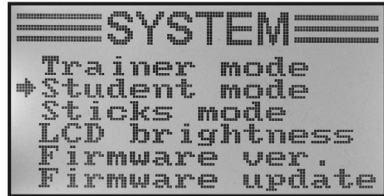

Figure 28

i) Control Stick Assignment „Sticks Mode“

As described previously for the receiver connection, the individual receiver outlets (channels) have specific functions or servos assigned to them. The first four outputs are assigned as follows:

CH1 = channel 1 (aileron/roll servo)

CH2 = channel 2 (elevator/nod servo)

CH3 = channel 3 (throttle servo/flight controller)

CH4 = channel 4 (rudder/tail servo)

When setting the control stick assignment, you can exactly determine the control stick you want to use to control outputs 1 - 4.

Setting the control stick assignment:

- Switch on the transmitter and call the system setting menu.
- Move the cursor arrow to the menu item „Sticks mode“ with the two buttons „UP“ and „DOWN“.
- Briefly push the button „OK“ to activate the menu item.

The display shows the currently used control stick assignment. The two circles with the lines offset by 90° are the two control sticks. Additionally, the control functions are displayed according to the control stick assignment.

- Pushing the buttons „UP“ or „DOWN“ permits setting the desired control stick assignment „Mode 1“ to „Mode 4“.
- Keep the button „CANCEL“ pushed for a longer period to save the settings. The display then shows the system setup menu again.
- Push the button „CANCEL“ repeatedly until you get back to the operating display.

Please observe that the control sticks are designed for „Mode 2“ or „Mode 4“ ex works. If you prefer „mode 1“ or „mode 3“, the stick units must be swapped.

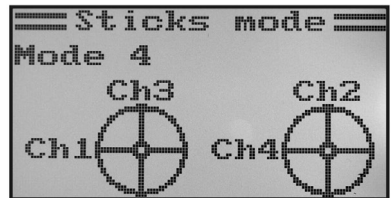
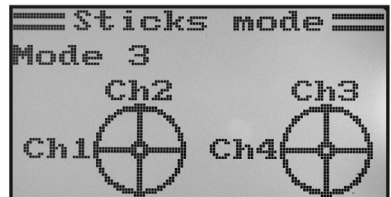
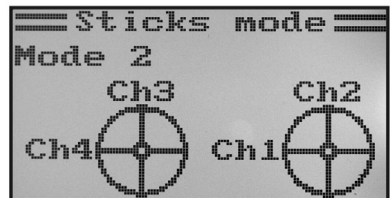
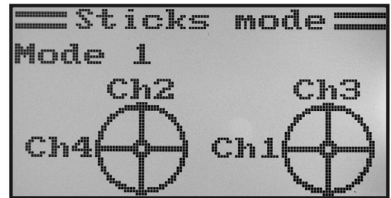
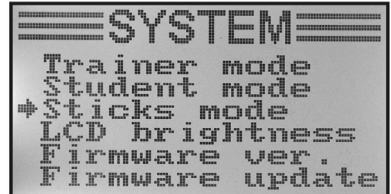

Figure 29

j) Display Brightness „LCD Brightness“

To have a perfectly legible display signals at all times, you can set the brightness value individually.

Setting the brightness value:

- Switch on the transmitter and call the system setting menu.
- Move the cursor arrow to the menu item „LCD brightness“ with the two buttons „UP“ and „DOWN“.
- Briefly push the button „OK“ to activate the menu item.

The currently set brightness value is displayed with a numeric value and a bar chart in the display. To better assess the brightness settings, the two model icons at the lower display edge are indicated as well.

- Push the buttons „UP“ or „DOWN“ to select the desired display brightness now. If the button „OK“ is pushed and held, the factory parameters are called.
- Keep the button „CANCEL“ pushed for a longer period to save the settings. The display then shows the system setup menu again.
- Push the button „CANCEL“ repeatedly until you get back to the operating display.

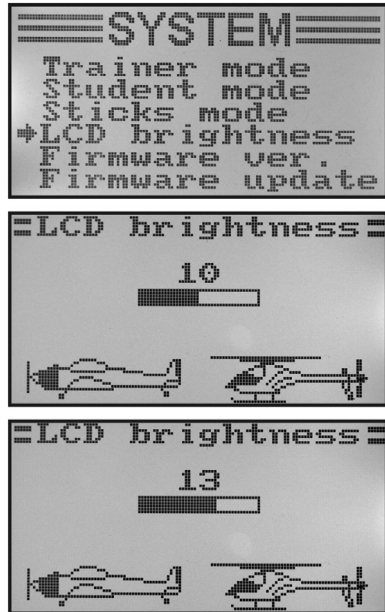

Figure 30

k) Transmitter Software Version „Firmware Ver.“

On demand, you can have the version number and the date of the transmitter software displayed. This way, you can recognise at once whether there is a newer software for the transmitter that can be installed (see following menu item).

Display of the transmitter software version:

- Switch on the transmitter and call the system setting menu.
- Move the cursor arrow to the menu item „Firmware ver.“ with the two buttons „UP“ and „DOWN“.
- Briefly push the button „OK“ to activate the menu item.

The transmitter designation, software version and date of the transmitter software are displayed in the display.

- Push the button „CANCEL“ repeatedly until you get back to the operating display.

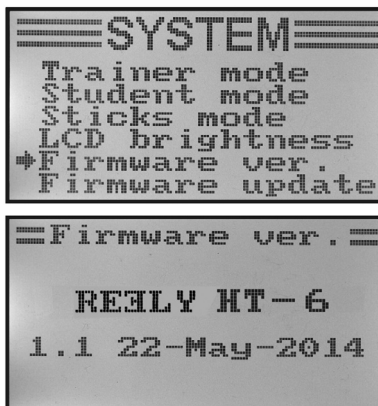

Figure 31

I) Transmitter Software Update „Firmware Update“

To transfer a newer version of the transmitter software to the remote control, the transmitter must be connected to a PC or notebook with an USB interface cable. For the data to be transmitted to the remote control, the transmitter must be put in the update mode. No receiver that belongs to the transmitter must be activated during this process.

Activating transmitter software:

- Switch on the transmitter and call the system setting menu.
- Move the cursor arrow to the menu item „Firmware update“ with the two buttons „UP“ and „DOWN“.
- Briefly push the button „OK“ to activate the menu item.

The display shows a message that the transmitter is switched to the update mode and all functions are stopped. You are asked to push the button „OK“ to activate the update function.

- After pushing the button „OK“, a safety prompt appears.
- Pushing the buttons „UP“ or „DOWN“ switches the cursor arrow from „No“ to „Yes“. Push the button „OK“ again to activate the update function.

The push of the button is in this case not confirmed with a sound but the display lighting is darkened. The display shows that the update function is active. The data transmission can now be started at the computer. All buttons at the remote control are out of order during the transmitter software update.

Switch the transmitter off and on again after the data transmission is completed.

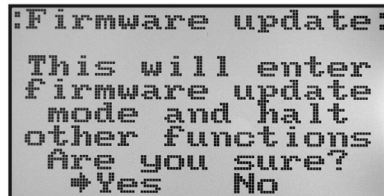
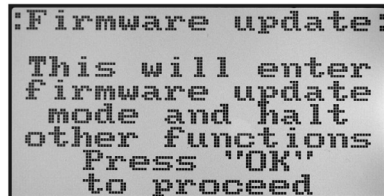
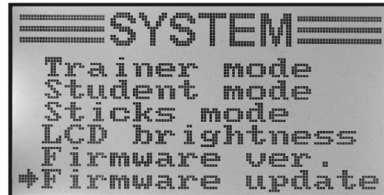

Figure 32



Important note:

Since the remote control was already equipped with the latest transmitter software ex works, a software update is usually not required. If it is required to renew the transmitter software in case of malfunction, send the remote control to our customer service department in Hirschau.

m) Reset to Factory Settings „Factory Reset“

With this function you have the option of deleting all the data of all model memories to their factory settings with a single command.



Attention!

When you call this function, all previously entered model data and settings are deleted! The remote control is returned to the delivery condition and all data must be entered again.

Factory reset:

- Switch on the transmitter and call the system setting menu.
- Move the cursor arrow to the menu item „Factory reset“ with the two buttons „UP“ and „DOWN“.
- Briefly push the button „OK“ to activate the menu item.

The display shows the message that the transmitter deletes all entered settings when resetting to factory settings. You are asked to push the button „OK“ to activate the reset function.

- After pushing the button „OK“, a safety prompt appears.
- Pushing the buttons „UP“ or „DOWN“ switches the cursor arrow from „No“ to „Yes“. Push the button „OK“ again to activate the reset function. The display shows the system setup menu again after a moment.
- Push the button „CANCEL“ repeatedly until you get back to the operating display.
- Then check the individual model memories afterwards for whether the personal setting values in them have been deleted.

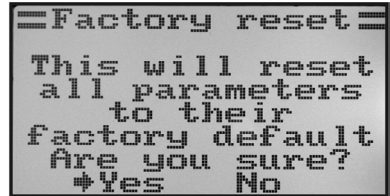
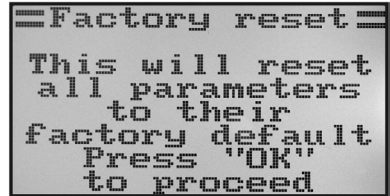
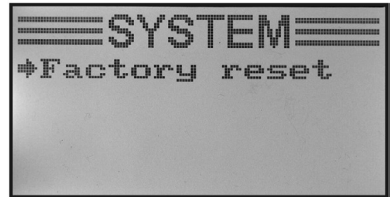

Figure 33

14. The Function Setting Menu „Functions Setup“

The specific settings for the respective models are made in the function setup menu. The menu items available in the function setup menu depends on which model type was selected in the system setup menu.

To get to the function settings menu, push the button „OK“ and hold it with the transmitter switched on. The operating display in the display switches to the menu display. The selection window around the remote control icon shows that you can call the system setup menu in this setting.

Push the button „UP“ or „DOWN“ so that the selection window frames the tools.

Briefly push the button „OK“ to get to the function settings menu.

The first 6 menu items of the function setting menu are now displayed.

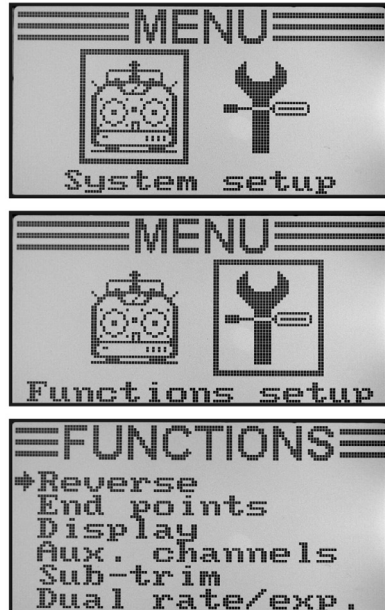

Figure 34

The following setting functions are available for you in the function setting menu:

Function	Display
Servo direction setting	„Reverse“
Servo end deflection setting	„End points“
Servo control/test	„Display“
Control encoder assignment	„Aux. channels“
Basic trim	„Subtrim“
Dual rate/exponential setting	„Dual rate/exp.“
Throttle curve setting	„Throttle Curve“
Pitch curve setting (only for helicopters with pitch function)	„Pitch Curve“
Swash plate servo settings	„Swash AFR“
Mixer programming	„Mix“
Delta mixer (for flight models only)	„Elevon“



V-tail mixer (flight models only)	„V tail“
Gyro sensitivity setting (for helicopter models only)	„Gyroscope“
Switch assignment	„Switches assign“
Throttle switching	„Throttle hold“



The menu items listed in the table are not all available in the function menu at the same time. Depending on the previously selected model type (helicopter or wing model), the menu items not needed or unsuitable for the required model are not displayed.

a) Servo Direction Setting „Reverse“

Depending on the position of the servos, a control movement to the left on the transmitter may invoke a steering movement to the right. This is why the transmitter allows you to individually set and save the rotting or running direction of every individual servo.

Adjusting the servo running directions

- Switch on the transmitter and call the function setting menu. The top menu item „Reverse“ is marked by the cursor arrow.
- Briefly push the button „OK“ to activate the menu item.

In the display you will see display items for the six control functions with the respective currently set running directions. „Nor“ corresponds to the standard running direction of the servo and „Rev“ to the reversed running direction.

- Pushing the button „UP“ or „DOWN“ changes the rotating direction of the servo at channel 1.
- When pushing the button „OK“, the cursor arrow will jump to channel 2.
- Pushing the button „UP“ or „DOWN“ changes the rotating direction of the servo at channel 2.
- Briefly push the button „OK“ to switch to channel 3.
- Repeat his process until you have set the correct running direction of the servos in all six channels.
- Keep the button „CANCEL“ pushed for a longer period to save the settings. The display then shows the function setup menu again.
- Push the button „CANCEL“ repeatedly until you return to the operating display and check if all servos have the correct running direction.

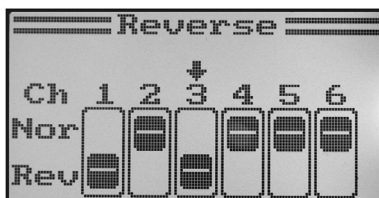
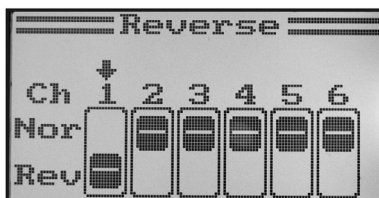
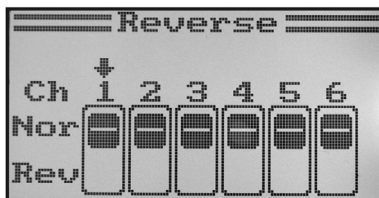
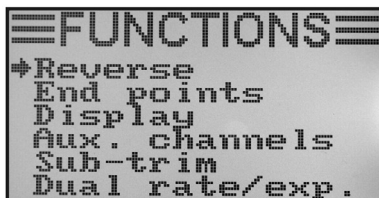

Figure 35

b) Servo End Deflection Setting „End Points“

Using the servo end deflection setting you can precisely define the maximum size of servo travel that is permitted on each side. The servo end deflection function is typically used to protect servos from mechanically hitting an obstacle when deflecting to the full extent. You can set a value from 0 to 120%. The smaller the value, the shorter the servo travel.



Always try to select the linkage points on the servo and the rudder sticks so that they reach maximum rudder deflections at the factory preset value of 100%.

The linked rods or sticks should not hit anything or be under any mechanical tension. This ensures that this function is only required to make minimal adjustments. The rudder travel values given in the model operating instructions which may be less than the maximum possible rudder travel values can be reduced later on with the dual rate function.

Setting the servo end deflection:

- Switch on the transmitter and call the function setting menu.
- Move the cursor arrow to the menu item „End points“ with the two buttons „UP“ and „DOWN“.
- Briefly push the button „OK“ to activate the menu item.

In the display you will see display items for the six control functions with the currently set servo end deflections.

- Move the control stick for channel 1 all the way to the left and then adjust the maximum possible servo deflection of the left side with the buttons „UP“ and „DOWN“.
- Then move the control stick for channel 1 all the way to the right and then adjust the maximum possible servo deflection of the right side with the buttons „UP“ and „DOWN“. If the button „OK“ is pushed and held, the factory parameters are called.
- When pushing the button „OK“ briefly, the cursor arrow will jump to channel 2. The servo deflection of channel 2 is set by the same principle as in channel 1.
- Repeat his process until you have set the correct servo end deflections in all six channels.
- Keep the button „CANCEL“ pushed for a longer period to save the settings. The display then shows the function setup menu again.
- Push the button „CANCEL“ repeatedly until you get back to the operating display.

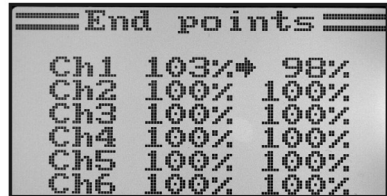
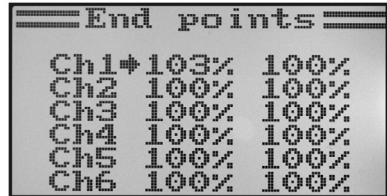
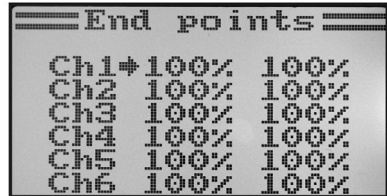
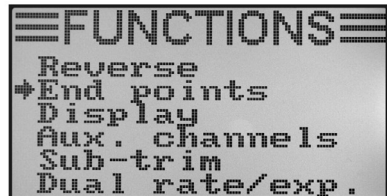

Figure 36

c) Servo Control/Test „Display“

In this menu you can graphically display the servo control settings for all 6 channels and simultaneously check the individual control functions with all mixers. Especially with helicopter models you can easily very quickly make mixer errors for swash plate control. The servos can be tested as well in this programme. For this, all six channels are automatically run from one end stop to the other and back.

Display servo control:

- Switch on the transmitter and call the function setting menu.
- Move the cursor arrow to the menu item „Display“ with the two buttons „UP“ and „DOWN“.
- Briefly push the button „OK“ to activate the menu item.

The display shows the 6 channels in the current position of the encoders.

If you move the control sticks, activated switches or rotating encoders in different directions now, you will see precisely which servo is controlled in which direction.

- Push and hold the button „CANCEL“ to start the servo test. The six bar displays now continually run from one end stop to the other. With the receiver activated, the servos react according to the bar charts.
- Push the button „OK“ to terminate the servo test. The display then shows the function setup menu again.
- Push the button „CANCEL“ repeatedly until you get back to the operating display.

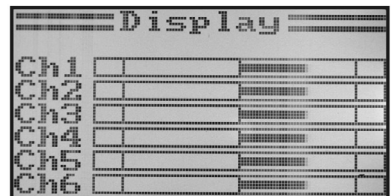
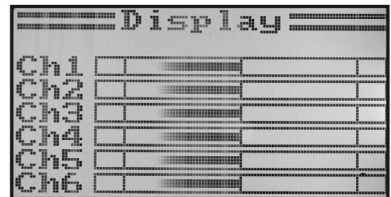
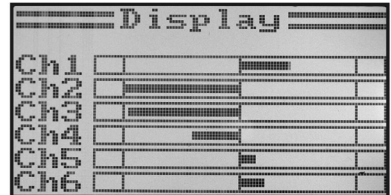
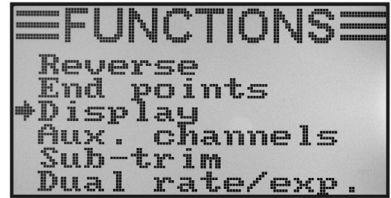

Figure 37

d) Encoder Assignment „Aux. Channels“

For the encoder assignment, you can set individual encoders for channels 5 and 6 (rotary encoder or toggle switch).



If you have any swash plate mixer or variable pitch control activated in the system setting menu, channel 6 is needed for rotor head linkage and therefore cannot be freely assigned. Channel 6 shows the display „Source Used“ (also see bottom-most figure 38).

Setting encoder assignment:

- Switch on the transmitter and call the function setting menu.
- Move the cursor arrow to the menu item „Aux. channels“ with the two buttons „UP“ and „DOWN“.
- Briefly push the button „OK“ to activate the menu item.

The display shows channels 5 and 6 in the respective assigned encoders „Source“. The two cursor arrows at channel 5 show that the encoder can be set at once in this channel.

- Push the buttons „UP“ or „DOWN“ to select the control encoder now. In addition to the four toggle switches „SwA - SwD“ and the two rotary encoders „VrA“ and „VrB“, the value „None“ can be selected as well when channel 5 is, e.g., not to be controlled manually but only via a mixer.
- When pushing the button „OK“, the cursor arrows will jump to channel 6.
- Push the buttons „UP“ or „DOWN“ to select the control encoder for channel 6 can be selected now.
- Keep the button „CANCEL“ pushed for a longer period to save the settings. The display then shows the function setup menu again.
- Push the button „CANCEL“ repeatedly until you get back to the operating display.

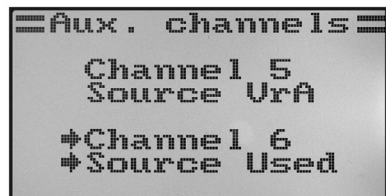
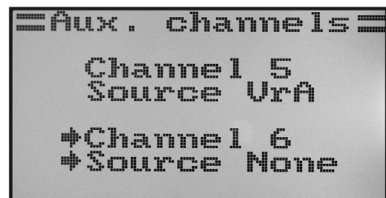
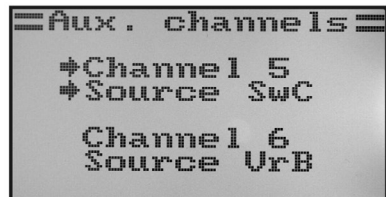
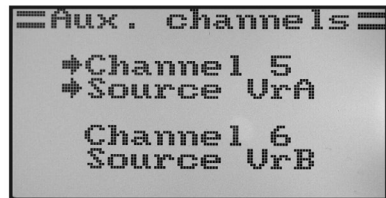
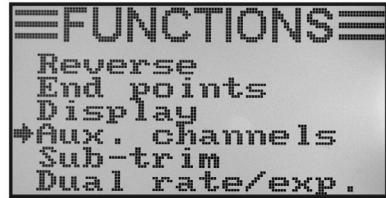

Figure 38

e) Basic Trim „Subtrim“

As previously mentioned when installing the servo, always mount the servo stick at a 90° angle to the linkage rods (see fig. 13). The trim displays at the transmitter (see fig. 4, items 5 - 8) should be in the centre position. Only then will you be able to perform fine trimming in both directions using the trim buttons during flight (see fig. 1, item 6, 8, 16 and 18).

However, the cog teeth on servo levers are often so large that the exact 90° angle cannot be set (see figure 13). This is why the basic trim helps to set the correct centre position of the servo arm without the need to adjust the trim buttons.



Important!

Before setting the basic trim, check with the operating display whether the four trim displays are set centrally.

Setting the basic trim:

- Switch on the transmitter and call the function setting menu.
- Move the cursor arrow to the menu item „Subtrim“ with the two buttons „UP“ and „DOWN“.
- Briefly push the button „OK“ to activate the menu item.

In the display you will see display items for the six control functions with the respective currently set trim values.

- Push the buttons „UP“ or „DOWN“ to select the base trim for channel 1.
- Brief pushing of the button „OK“ will cause the cursor arrow to jump to channel 2. If the button „OK“ is pushed and held, the factory parameter will be called.
- Push the buttons „UP“ or „DOWN“ to select the base trim for channel 2.
- Repeat his process until you have set the desired basic trim in all six channels.
- Keep the button „CANCEL“ pushed for a longer period to save the settings. The display then shows the function setup menu again.
- Push the button „CANCEL“ repeatedly until you get back to the operating display.

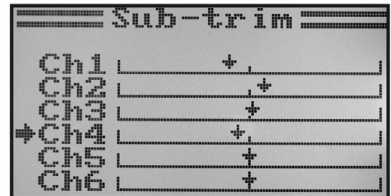
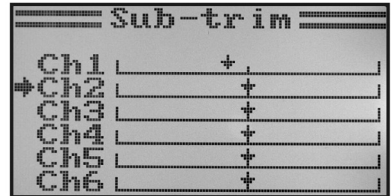
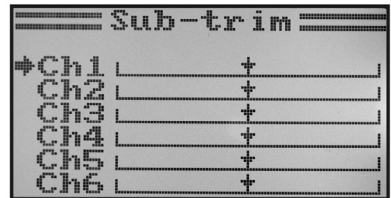
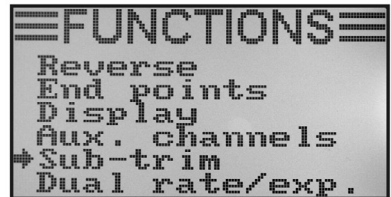

Figure 39

f) Dual Rate/Exponential Setting „Dual Rate/Exp.“

The dual rate function:

The dual rate function allows you to reduce the servo deflections of channels 1, 2 and 4 by operating the flight condition switch. You can do this to simply and easily reduce the reaction sensitivity of a model which reacts too aggressively at full extension. Especially for beginners, models with reduced rudder deflections are a lot easier to control.

When a model is used for the first time, it might not yet be clear how sensitively it responds to the control commands. Therefore it is a proven method to reduce the deflections during flight.

Exponential Function:

In contrast to the dual rate function, the end deflections of the servos are not reduced in the exponential function. The exponential function merely reacts to the middle range of the control curve. In practice, this means that the reaction to the control stick is no longer linear, but forms a curve. When the curve shape is flattened in the middle, the model will react more sensitively to the control commands in the middle area of the control sticks. This is required when large rudder deflections are set for extreme aerobatics.

Setting the dual rate/exponential function:

- Switch on the transmitter and call the function setting menu.
- Move the cursor arrow to the menu item „Dual rate/exp.“ with the two buttons „UP“ and „DOWN“.
- Briefly push the button „OK“ to activate the menu item.

The display shows the displays for the dual rate and exponential functions for channel 1. At the same time, a control curve diagram and the flight condition „Normal“ (the switch „SWA“ needs to be in the front position for this) are displayed.

In the flight condition „Normal“, reduced rudder deflections are set, in flight condition „Sport“, larger ones are used.

- Pushing the buttons „UP“ and „DOWN“ selects the channel in which the dual rate and exponential values for the flight condition „Normal“ are to be set.
- When pushing the button „OK“, the cursor arrow will jump to the dual rate setting value.
- Push the buttons „UP“ or „DOWN“ to set the reduced servo deflection. The slant of the control curve changes according to the setting.
- When pushing the button „OK“ briefly again, the cursor arrow will jump to the exponential setting value. If the button „OK“ is pushed and held, the factory parameters are called.

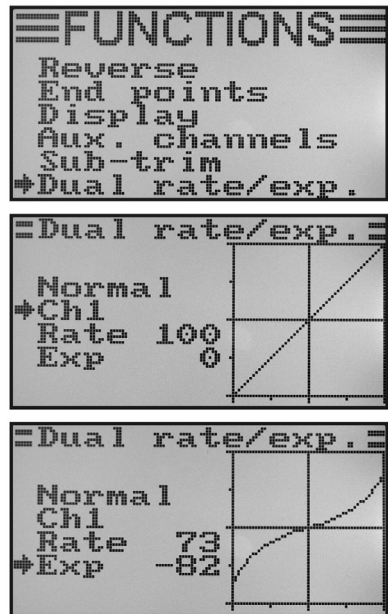

Figure 40a

- Push the buttons „UP“ or „DOWN“ to set the shape of the control curve.
- If a negative setting value is selected, the curve shape becomes flatter in the middle area. If a Positive setting value is selected, the curve shape becomes steeper in the middle area. If the button „OK“ is pushed and held, the factory parameters are called.
- Repeat his process until you have set the desired dual rate and exponential values for flight condition „Normal“ in all three channels.
- Now operate the toggle switch „SWA“ to call the flight condition „Sport“.



On demand, another toggle switch for switching the flight conditions can be assigned in the following menu switch assignment menu (Switches assign).

- Repeat the above process again and set the desired dual rate and exponential values for flight condition „Sport“ in all three channels as well.

For setting „Sport“, the settings should be larger than for the setting „Normal“, which leads to a much more agile model.

- Keep the button „CANCEL“ pushed for a longer period to save the settings. The display then shows the function setup menu again.
- Push the button „CANCEL“ repeatedly until you get back to the operating display.



Deflect the steering stick for the individual functions to the stop and confirm the flight condition switch. Now check if the full rudder deflections (switch position Sport and the reduced rudder deflections (switch position Normal correspond to your ideas or the manufacturer information of the flight model.

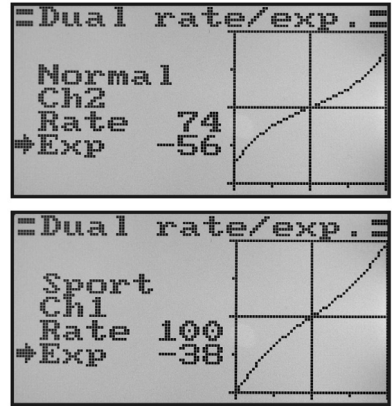

Figure 40b

g) Throttle Curve Setting „Throttle Curve“

In a proportional remote control unit the control stick and the corresponding servo maintain linear reactions (also see second figure from the top in image 40a). This means: Moving the control element from one side to the other results in the corresponding servo arm moving from one side to the other.

If the throttle/pitch control stick (or stick) on the transmitter is in the lowest position (L), the throttle flap must be almost fully closed.

If the control stick is then moved to the middle position (2), the throttle flap should be approx. 50% open.

If the control stick is in the uppermost position (H), the carburetor should be fully open so that the motor can run at full power. The throttle curve thus corresponds to a straight line (see the adjacent sketch).

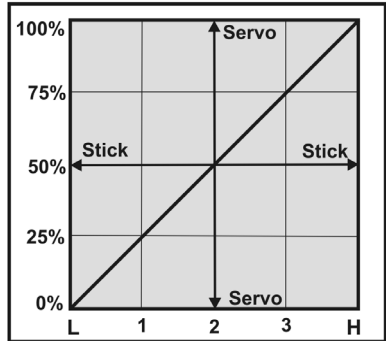

Figure 41

With the throttle curve setting, the shape of the throttle curve can be changed specifically in 5 points and the settings can be saved.

Setting the throttle curve:

- Switch on the transmitter and call the function setting menu.
- Move the cursor arrow to the menu item „Throttle Curve“ with the two buttons „UP“ and „DOWN“.
- Briefly push the button „OK“ to activate the menu item.

The display shows the indications for the percentage setting values for the five points of the throttle curve (L, 1, 2, 3 and H), the control curve chart and the flight condition „Normal“. (the switch „SWB“ must be in the front position for this).

The vertical dash in the chart marks the current position of the throttle control stick.

In the flight condition „normal“, the throttle curve should be set for the combustion engine to run at the lowest speed when the control stick is in the idle position. In helicopter models, the centre part of the throttle curve may be a little flattened to permit a fine hover flight.

- Pushing the buttons „UP“ or „DOWN“ selects the percentage input value for the bottom point of the throttle curve in the flight condition „normal“. If the button „OK“ is pushed and held, the factory parameters are called.

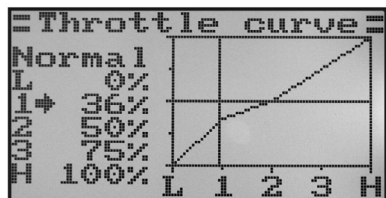
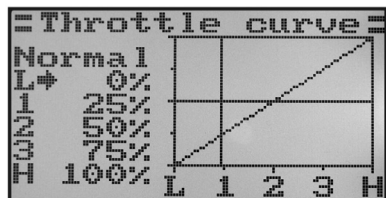
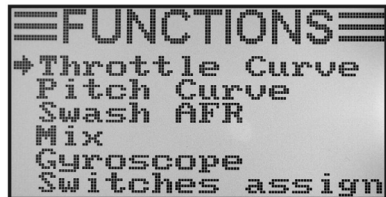

Figure 42a

- When briefly pushing the button „OK“, the cursor arrow will jump to the throttle curve setting point „1“.
- Push the buttons „UP“ or „DOWN“ to set the percentage input value for this point.
- Repeat this process until you have set the desired value for the flight condition „Normal“ in all five points.
- Now operate the toggle switch „SWB“ to call the flight condition „Idle up“.



On demand, another toggle switch for switching the flight conditions can be assigned in the following menu switch assignment menu (Switches assign).

In flight condition „Idle up“, the idle speed can be increased a little to warrant secure running of the engine.

The throttle curve is set in a V-shape in helicopter models to have sufficient motor power available in reverse flight as well.

- Repeat the above process again and set the desired value of the throttle curve for all five points in the flight condition „Idle up“ as well.
- Keep the button „CANCEL“ pushed for a longer period to save the settings. The display then shows the function setup menu again.
- Push the button „CANCEL“ repeatedly until you get back to the operating display.

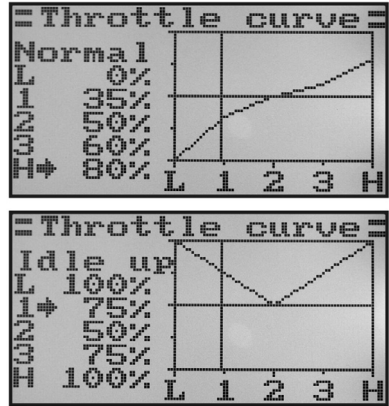

Figure 42b

h) Pitch Curve Setting „Pitch Curve“



This menu is only available if a helicopter with variable pitch function or swash 90°, 120° or 140° was selected in the system settings menu!

Just like the throttle curve, the pitch curve can be individually set in all five points. It is no matter whether you are using a model with only one pitch servo or the swash plate is controlled by three servos at once.

Setting the pitch curve:

- Switch on the transmitter and call the function setting menu.
- Move the cursor arrow to the menu item „Pitch Curve“ with the two buttons „UP“ and „DOWN“.
- Briefly push the button „OK“ to activate the menu item.

The display shows the indications for the percentage setting values for the five points of the pitch curve (L, 1, 2, 3 and H), the control curve chart and the flight condition „Normal“ (the switch „SWB“ has to be in the front position for this).

The vertical dash in the chart marks the position of the pitch control stick.

In flight condition „Normal“, the values of the pitch curve should be reduced a little to keep the curve flatter. The model helicopter will thus be controllable more easily and delicately in hover flight this way.

- Pushing the buttons „UP“ or „DOWN“ selects the percentage input value for the bottom point of the pitch curve in the flight condition „normal“. If the button „OK“ is pushed and held, the factory parameters are called.
- When briefly pushing the button „OK“, the cursor arrow will jump to the pitch curve setting point „1“. Push the buttons „UP“ or „DOWN“ to set the percentage input value for this point.
- Repeat this process until you have set the desired value for the flight condition „Normal“ in all five points.
- Now operate the toggle switch „SWB“ to call the flight condition „Idle up“.

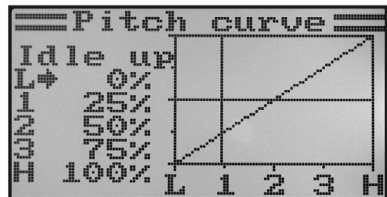
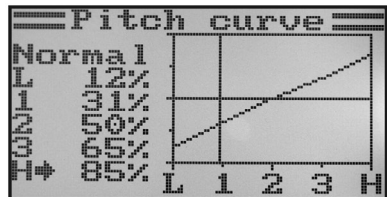
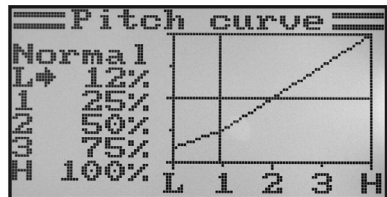
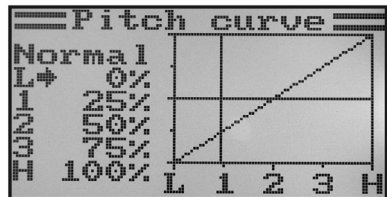
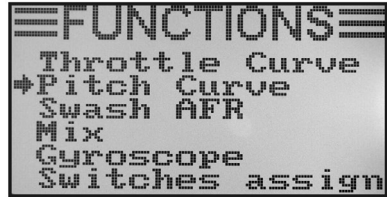

Figure 43



On demand, another toggle switch for switching the flight conditions can be assigned in the following menu switch assignment menu (Switches assign).

In the flight condition „Idle up“, the pitch curve should be set so that the rotor blades reach the maximum positive and negative angle of attack.

- Repeat the above process again and set the desired value of the pitch curve for all five points in the flight condition „Idle up“ as well.
- Keep the button „CANCEL“ pushed for a longer period to save the settings. The display then shows the function setup menu again.
- Push the button „CANCEL“ repeatedly until you get back to the operating display.



Attention!

Precise information on the respective angles of attach of the rotor blades in the different flight conditions can usually be taken from the documents of the model helicopter.

Important:

Please observe that the pitch and throttle curves influence each other. If you lift the pitch curve in a specific point, the larger angle of attack of the rotor blades may require lifting the throttle curve in this point as well.

i) Swash Plate Servo Setting „Swash AFR“



This menu is only available if a helicopter with swash 90°, 120° or 140° was selected in the system settings menu!

In this menu, you can adjust the mixing ratio of the swash plate servos to each other. In this way you can perfectly set the correct movement direction and the required angle of deflection or shift path of the swash plate in reaction to the transmitter control signals.

Adjusting the swash plate servos:

- Switch on the transmitter and call the function setting menu.
- Move the cursor arrow to the menu item „Swash AFR“ with the two buttons „UP“ and „DOWN“.
- Briefly push the button „OK“ to activate the menu item.

The display shows the currently set swash plate mixer (e.g. „Swash type 120°“) and the set values for the roll function (Aileron), for the nod function (Elevator) and the pitch function (Pitch).

- Alternatingly deflect the control ever for the roll function to the stop and push the buttons up and down to adjust the tipping movement to the desired inclination by turning the swash plate to the right and left. If a negative value is entered, the movement direction of the swash plate will change.

The precise values then must be determined and adjusted in several test flights.

If the button „OK“ is pushed and held, the factory parameters are called.

- When pushing the button „OK“ briefly, the cursor arrow will jump to the nod function.
- Alternatingly deflect the control ever for the nod function to the stop and push the buttons up and down to adjust the tipping movement to the desired inclination by turning the swash plate to the front and rear. If a negative value is entered, the movement direction of the swash plate will change.

The precise setting values for this function must be determined by several test flights as well.

If the button „OK“ is pushed and held, the factory parameters are called.

- When pushing the button „OK“ again briefly, the cursor arrow will jump to the pitch function.

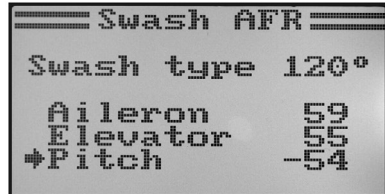
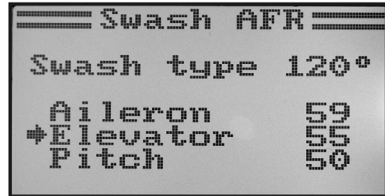
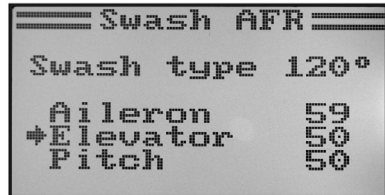
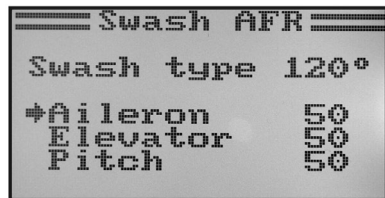
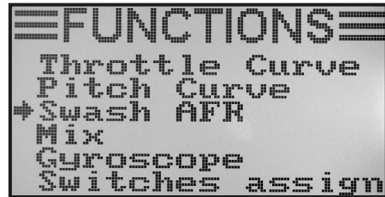

Figure 44

- Alternatingly deflect the control lever for the pitch function to the stop and push the buttons „UP“ or „DOWN“ to set the path of the swash plate up and down. If the button „OK“ is pushed and held, the factory parameters are called. If a negative value is entered, the movement direction of the swash plate will change.
- Keep the button „CANCEL“ pushed for a longer period to save the settings. The display then shows the function setup menu again.
- Push the button „CANCEL“ repeatedly until you get back to the operating display.



Important:

Adjust the swash plate paths so that even min. and max. pitch will still provide the maximum nod and roll path without the swash plate linkage topping mechanically or being limited.

j) Mixer Programming „Mix“

This programing permits controlling a slave channel via a master channel. The slave channel is taken along linearly, with the two deflection directions and the deflection values of the slave servo, as well as the working point of the mixer being programmable individually. All in all, 3 freely programmable linear mixers „Mix #1“ - „Mix #3“ are available.

Adjusting the mixers:

- Switch on the transmitter and call the function setting menu.
- Move the cursor arrow to the menu item „Mix“ with the two buttons „UP“ and „DOWN“.
- Briefly push the button „OK“ to activate the menu item.

The display shows the indication for mixer #1 with the pre-set mixing values.

- Push the buttons „UP“ or „DOWN“ to select the desired mixer „Mix #1 - Mix #3“.
- When pushing the button „OK“, the cursor arrow will jump to the mixer function. Pushing the buttons „UP“ or „DOWN“ can activate „On“ or deactivate „Off“ the mixing function.
- When pushing the button „OK“, the cursor arrow will jump to the master channel. Push the buttons „UP“ or „DOWN“ to select the master channel now.
- When pushing the button „OK“ again, the cursor arrow will switch to the slave channel. Push the buttons „UP“ or „DOWN“ to select the slave channel now.

```

=====FUNCTIONS=====
Throttle Curve
Pitch Curve
Swash AFR
➔Mix
Gyroscope
Switches assign
    
```

```

=====Mix=====
➔Mix #1
Mix is           Off
Master          Ch1
Slave           Ch2
Pos. mix        50%
Neg. mix        50%
Offset          0%
    
```

```

=====Mix=====
Mix #1
➔Mix is           On
Master          Ch1
Slave           Ch2
Pos. mix        50%
Neg. mix        50%
Offset          0%
    
```

```

=====Mix=====
Mix #1
Mix is           On
➔Master          Ch1
Slave           Ch2
Pos. mix        50%
Neg. mix        50%
Offset          0%
    
```

```

=====Mix=====
Mix #1
Mix is           On
Master          Ch1
➔Slave          Ch6
Pos. mix        50%
Neg. mix        50%
Offset          0%
    
```

Figure 45

- When pushing the button „OK“, the cursor arrow will jump to the positive mixed value.
- Deflect the encoder of the master channel to the stop on one side. Push the buttons „UP“ or „DOWN“ to set the slave servo deflections individually now. If the button „OK“ is pushed and held, the factory parameters are called.



If the slave servo does not react to the changes of the set value, deflect the encoder of the master channel on the other side to the stop. When the slave servo is to have the same deflection path as the master servo, the value 100% must be set here. When setting a negative %-value, the running direction of the slave servo will change.

- When pushing the button „OK“ again briefly, the cursor arrow will switch to the negative mix value.
- Deflect the encoder of the master channel on the other side to the stop. The setting is performed according to the same principle as with a positive mixing value.
- Push the button „OK“ again so that the cursor arrow will switch to the offset value. Push the buttons „UP“ or „DOWN“ to set the required offset value (see subsequent explanation). If the button „OK“ is pushed and held, the factory parameters are called.
- Keep the button „CANCEL“ pushed for a longer period to save the settings. The display then shows the function setup menu again.
- Push the button „CANCEL“ repeatedly until you get back to the operating display.

```

===== Mix =====
Mix #1
Mix is      On
Master     Ch1
Slave      Ch6
➔Pos. mix   50%
Neg. mix    50%
Offset      0%
  
```

```

===== Mix =====
Mix #1
Mix is      On
Master     Ch1
Slave      Ch6
➔Pos. mix   100%
Neg. mix    50%
Offset      0%
  
```

```

===== Mix =====
Mix #1
Mix is      On
Master     Ch1
Slave      Ch6
Pos. mix    100%
➔Neg. mix   100%
Offset      0%
  
```

```

===== Mix =====
Mix #1
Mix is      On
Master     Ch1
Slave      Ch6
Pos. mix    100%
Neg. mix    100%
➔Offset     0%
  
```

Figure 46

The offset settings:

The offset point is the position of the master encoder from which the servo channel is added. If the value 0% is set, the offset point is in the centre position of the master encoder. If the master encoder is then deflected from the centre to the left and right, the slave servo will also deflect to the left and right if the deflection values are set accordingly.

There also is the option of deflecting the offset point. This is recommended when the slave servo is to deflect in only one direction and the master encoder is a „non-self-neutralising encoder“, such as a rotary encoder or the throttle/pitch stick.

Practical example:

If a glider model has spoiler flaps in the wings, they are usually controlled via the throttle stick (see schematic illustration in sketch A and B).

With the stick in front (top figure, sketch A), the spoiler flaps are retracted. If the control stick is pulled back to the body, the spoiler flaps extend. In most models, an elevator deflection must be mixed in for the model to fly on straight.

Without offset setting (sketch A), the elevator would be deflected down and up according to the values set with the flaps retracted and extended.

With half-extended spoiler flaps, the elevator is in the centre position since the throttle stick is also in the centre position (see middle drawing, sketch A).

Use the offset setting (sketch B) to move the throttle stick all the way to the front and to change the offset value so that the elevator is in the centre position again (see top drawing in sketch B).

If the throttle stick is now moved back to the centre position, the required elevator deflection is mixed in.

➔ Since the max. elevator addition is already reached at the centre position of the throttle stick, the elevator deflection will no longer change if the throttle stick is taken back farther.

For better illustration, the mixed-in elevator deflection in the drawings in figure 47 was illustrated much larger than it actually has to be.

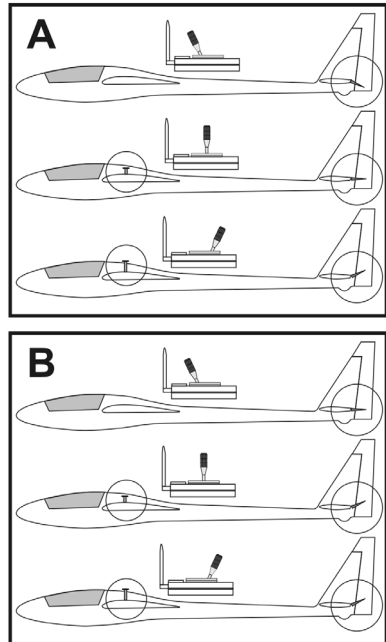

Figure 47

k) Delta Mixer „Elevon“



This menu is only available if a flight model was selected in the system settings menu!

For pure wing or delta flight models, the rudder flaps for the aileron function are also used for the elevator function, with each rudder blade being controlled with a separate servo.

The servo for the right rudder blade/elevon is connected to channel 1 (CH1) and the servo for the left rudder blade to channel 2 (CH2) of the receiver (see sketch A).

In that case, both servos carry out the elevator (ELEVATOR) and aileron (AILERON) = ELEVON control together.

If the elevator control stick is pulled towards the pilot, both rudders (elevons) must deflect upwards (Sketch B) when looking at the model from behind.

If the elevator control stick is pushed all the way to the front, both rudders must deflect downwards (Sketch C) when looking at the model from behind.

If the aileron control stick is moved all the way to the left, the left elevon must deflect upwards and the right elevon must deflect downwards (Sketch D) when looking at the model from behind.

If the aileron control stick is moved all the way to the right, the left elevon must deflect downwards and the right elevon must deflect upwards (Sketch E) when looking at the model from behind.

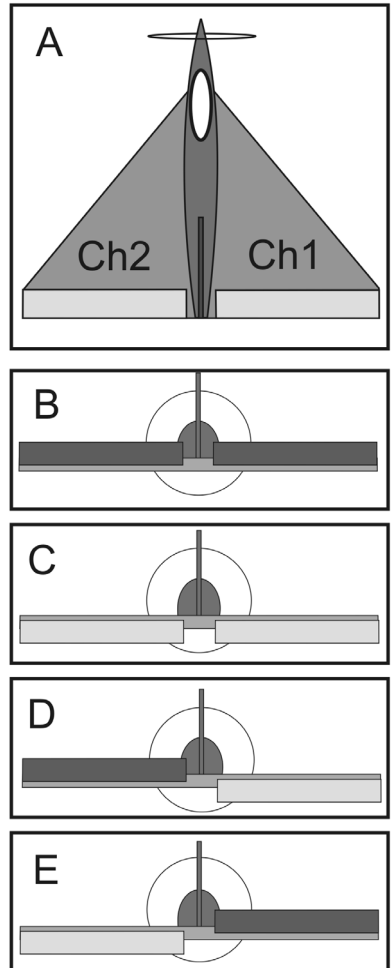

Figure 48

Setting the delta mixer:

- Switch on the transmitter and call the function setting menu.
- Move the cursor arrow to the menu item „Elevon“ with the two buttons „UP“ and „DOWN“.
- Briefly push the button „OK“ to activate the menu item.

The display shows the mixer indication with pre-set values.

- Pushing the buttons „UP“ or „DOWN“ can activate „On“ or deactivate „Off“ the mixer.
- When pushing the button „OK“, the cursor arrow will jump to the deflection values for the aileron function (CH1).
- Alternatingly deflect the encoder for the aileron function on the one side to the stop and adjust the desired deflection values of both servos by pushing the buttons „UP“ or „DOWN“. When setting a negative value, the running directions of the two servos will reverse. If the button „OK“ is pushed and held, the factory parameters are called.
- When pushing the button „OK“ briefly again, the cursor arrow will jump to the deflection values for the elevator function (CH2).
- Alternatingly deflect the encoder for the elevator function down or up to the stop and adjust the desired deflection values of both servos by pushing the buttons „UP“ or „DOWN“. If the button „OK“ is pushed and held, the factory parameters are called.
- Keep the button „CANCEL“ pushed for a longer period to save the settings. The display then shows the function setup menu again.
- Push the button „CANCEL“ repeatedly until you get back to the operating display.

➔ If one of the two servos runs in the wrong direction, you can use the reverse setting (see chapter 14. a) to change the running direction of the servo.

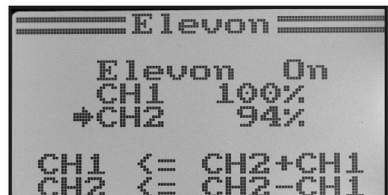
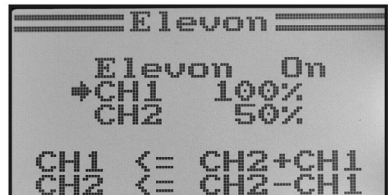
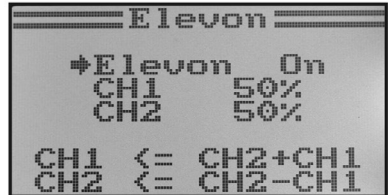
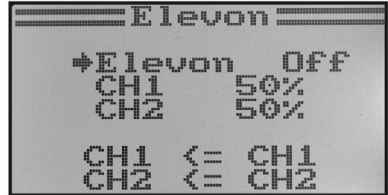
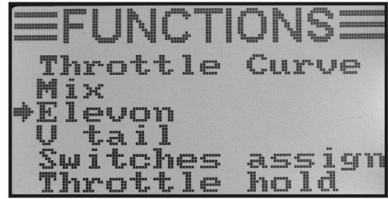

Figure 49

I) V-Tail Mixer „V Tail“



This menu is only available if a flight model was selected in the system settings menu!

Flight models with a V-tail require every rudder blade to be controlled by an individual servo. In that case, both servos carry out the elevator and rudder control together.

The servo for the right rudder blade is connected to channel 2 (CH2) and the servo for the left rudder blade to channel 4 (CH4) of the receiver.

As in the case with a cross tail or a T-tail, the rudder blades must be in a line with the dampening areas and must not point upwards or downwards when the control sticks at the transmitter are not deflected (Sketch A).

If the elevator control stick is pulled towards the pilot, both rudders must deflect upwards (Sketch B) when looking at the model from behind.

If the elevator control stick is pushed all the way to the front, both rudders must deflect downwards (Sketch C) when looking at the model from behind.

If the rudder control stick is moved all the way to the left, the left rudder must deflect upwards and the right rudder must deflect downwards (Sketch D) when looking at the model from behind.

If the rudder control stick is moved all the way to the right, the left rudder must deflect downwards and the right rudder must deflect upwards (Sketch E) when looking at the model from behind.

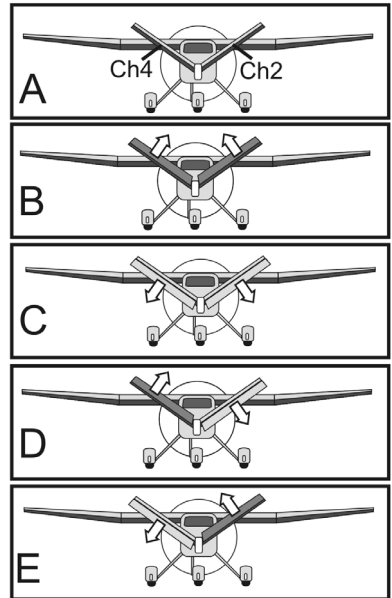



Figure 50

Adjusting the V-tail mixer:

- Switch on the transmitter and call the function setting menu.
- Move the cursor arrow to the menu item „V tail“ with the two buttons „UP“ and „DOWN“.
- Briefly push the button „OK“ to activate the menu item.

The display shows the mixer indication with pre-set values.

- Pushing the buttons „UP“ or „DOWN“ can activate „On“ or deactivate „Off“ the mixer.
- When pushing the button „OK“, the cursor arrow will jump to the deflection values for the elevator function (CH2).
- Alternatingly deflect the encoder for the elevator function down or up to the stop and adjust the desired deflection values of both servos by pushing the buttons „UP“ or „DOWN“. When setting a negative value, the running directions of the two servos will reverse. If the button „OK“ is pushed and held, the factory parameters are called.
- When pushing the button „OK“ briefly again, the cursor arrow will jump to the deflection values for the rudder function (CH4).
- Alternatingly deflect the encoder for the rudder function on the one side to the stop and adjust the desired deflection values of both servos by pushing the buttons „UP“ or „DOWN“. If the button „OK“ is pushed and held, the factory parameters are called.
- Keep the button „CANCEL“ pushed for a longer period to save the settings. The display then shows the function setup menu again.
- Push the button „CANCEL“ repeatedly until you get back to the operating display.

 If one of the two servos runs in the wrong direction, you can use the reverse setting (see chapter 14. a) to change the running direction of the servo.

 **Caution, important!**
The remote control transmitter does not permit concurrent operation of the delta and V-tail mixer. In this case, the following error message will be displayed when the second mixer is called: „Elevon enabled“ or „V tail enabled“.

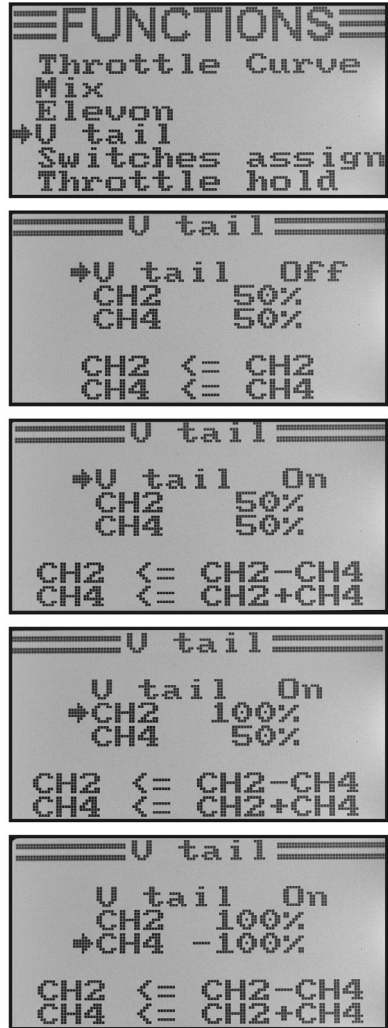

Figure 51

m) Gyro Sensitivity Setting „Gyroscope“



This menu is only available if a helicopter model was selected in the system settings menu!

So-called gyroscope (or gyro) systems are used in order to stabilise the tail of the helicopter in the air. There is a connection between the receiver and the tail servo. If the tail turns sideways as a result of a wind gust or other external influences, this is recognised by the gyro and a corresponding control command is sent to the tail servo to counter the turn. Gyroscope systems that have an additional controller input permit setting the individual sensitivity for each flight condition separately and independently of each other. This requires the controller input for the gyro to be connected to channel 5 of the receiver.

For further information, refer to the design documents of the gyro system.

Setting the gyro sensitivity:

- Switch on the transmitter and call the function setting menu.
- Move the cursor arrow to the menu item „Gyroscope“ with the two buttons „UP“ and „DOWN“.
- Briefly push the button „OK“ to activate the menu item.

The display shows the current switching condition of the gyro sensitivity, the flight condition „Normal“ (the switch „SWB“ must be in the front position for this) and the set value. The cursor arrow in the mixer function shows that the gyro sensitivity now can be activated or deactivated.

- Pushing the buttons „UP“ or „DOWN“ can activate „On“ or deactivate „Off“ gyro sensitivity.
- When pushing the button „OK“, the cursor arrow will jump to the setting value for gyros sensitivity.
- Push the buttons „UP“ or „DOWN“ to set the gyro sensitivity for the flight condition „Normal“. If the button „OK“ is pushed and held, the factory parameters are called.

```
=====FUNCTIONS=====
Throttle Curve
Pitch Curve
Swash AFR
Mix
+Gyroscope
Switches assign
```

```
=====Gyroscope=====

+Gyro   Off
Mode    Normal
Value   50%
```

```
=====Gyroscope=====

+Gyro   On
Mode    Normal
Value   50%
```

```
=====Gyroscope=====

Gyro    On
Mode    Normal
+Value  81%
```

Figure 52a

- Then push the toggle switch „SWB“ to call the flight condition „Idle up“.
- Now set the required gyro sensitivity for this flight condition as well.
- Keep the button „CANCEL“ pushed for a longer period to save the settings. The display then shows the function setup menu again.
- Push the button „CANCEL“ repeatedly until you get back to the operating display.

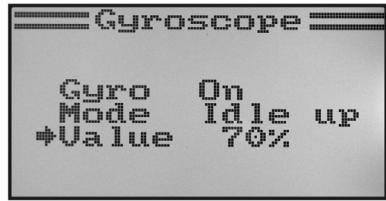

Figure 52b



On demand, another toggle switch for switching the flight conditions can be assigned in the following menu switch assignment menu (Switches assign).

n) Switch Assignment „Switches Assign“

In this menu, you can individually specify which switch you want to use for the different flight conditions or the throttle switch (see last menu item).

Switch assignment setting:

- Switch on the transmitter and call the function setting menu.
- Move the cursor arrow to the menu item „Switches assign“ with the two buttons „UP“ and „DOWN“.
- Briefly push the button „OK“ to activate the menu item.

The display shows the three switching options with the respective assigned switches. Depending on the current position of the switches, the displays show „Normal“ and „Off“ or „Sport“, „idle up“ and „On“.

- Pushing the buttons „UP“ or „DOWN“ chooses which one of the toggle switches „SwA“, „SwB“ or „SwD“ should be used for switching the flight conditions „Normal“ and „Sport“.
- When pushing the button „OK“, the cursor arrow will jump to switching the next flight condition „Normal“ and „Idle up“.
- Pushing the buttons „UP“ or „DOWN“ selects which toggle switch is to be used for this switching.
- The switch for throttle switching is selected according to the same principle.
- Keep the button „CANCEL“ pushed for a longer period to save the settings. The display then shows the function setup menu again.
- Push the button „CANCEL“ repeatedly until you get back to the operating display.

```

=====FUNCTIONS=====
Throttle Curve
Pitch Curve
Swash AFR
Mix
Gyroscope
➔Switches assign
    
```

```

:Switches assign:
➔Fly mode      SwA
  Normal
Idle mode      SwB
  Normal
Thro. hold    SwD
  Off
    
```

```

:Switches assign:
➔Fly mode      SwD
  Normal
Idle mode      SwB
  Normal
Thro. hold    SwD
  Off
    
```

```

:Switches assign:
➔Fly mode      SwD
  Sport
Idle mode      SwB
  Normal
Thro. hold    SwD
  Off
    
```

```

:Switches assign:
Fly mode      SwD
  Sport
Idle mode      SwB
  idle up
➔Thro. hold    SwA
  On
    
```

Figure 53

o) Throttle Switch „Throttle Hold“

In order to be able to practice an autorotation landing, you need to uncouple the motor function from the pitch stick using a toggle switch. The combustion engine must be at sufficient throttle so that the centrifugal clutch is reliably open. Nevertheless, the motor should be set so that it spontaneously takes in gas and can be restarted immediately if the situation so requires.

The function can also be used as a safety switch. If the model is carried to the starting point after starting up the combustion engine, the throttle switch can be activated. Accidental adjustment of the throttle control stick then will not lead to undesired revving up of the engine.

Setting the throttle switch:

- Switch on the transmitter and call the function setting menu.
- Move the cursor arrow to the menu item „Throttle hold“ with the two buttons „UP“ and „DOWN“.
- Briefly push the button „OK“ to activate the menu item.

The display shows the current switching condition of the throttle switch and the set value. The respective setting of the toggle switch for the throttle switch is also displayed at the lower edge of the display. The display „Not engaged“ shows that the throttle switch is deactivated. „Engaged“ means that the throttle switch is activated.

- Pushing the buttons „UP“ or „DOWN“ can activate „On“ or deactivate „Off“ the throttle switching.
- When pushing the button „OK“, the cursor arrow will jump to the setting value for throttle switching.
- Pushing the buttons „UP“ or „DOWN“ permits setting the throttle servo with activated throttle switching so that the motor will securely run through in idle operation. If the button „OK“ is pushed and held, the factory parameters are called.
- Keep the button „CANCEL“ pushed for a longer period to save the settings. The display then shows the function setup menu again.
- When pushing the toggle switch for throttle switching, the motor has to switch between the set idle speed and the speed corresponding to the current position of the control stick for the throttle function.
- Push the button „CANCEL“ repeatedly until you get back to the operating display.

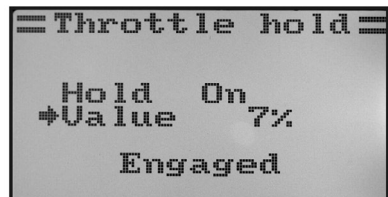
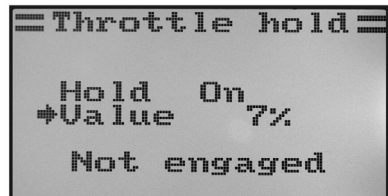
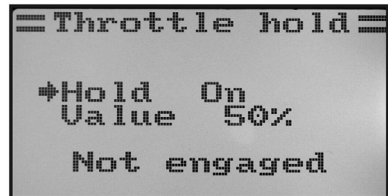
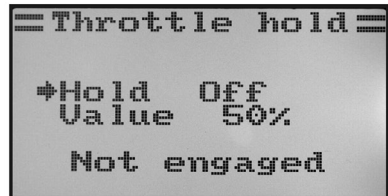
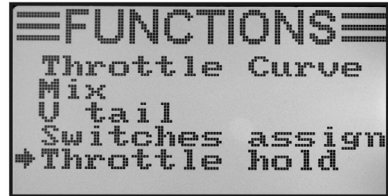

Figure 54

15. Remote Control Operation

The best remote control is of little use if the batteries used are flat and the rechargeable batteries have not been charged. Thus, you should Check the transmitter batteries (battery tester) and charge the receiver batteries to the manufacturer's specifications before every day's flying. It is important that you don't just quickly charge the batteries a little. Use suitable devices with a discharge function so that you have an exact overview of the current power capacity of your rechargeable batteries.

Before you operate your model in the flying area, first check the correct setting of the remote control. It is particularly important to ensure the correct model memory is activated and that the trim buttons are set to the respective centre settings. Also be sure to test the correct setting of all switches and dials.

Switch on the receiver system in the model and check all control functions at the model then. Only perform a range test with the engine running before the first flight. For this, a helper has to hold the model about 1m above the ground. At a direct line of sight, the model must react without defects to the control signals even from a distance of at least 400 m.

Once you have checked your range and all functions are working without defects, you can start your model. If your model does not fly straight, you have the option of trimming the rudders in flight. Since you should always have sight contact to the model during flight, changes to the trimming are indicated by a sound. The remote control emits a short signal sound for each press of a trim stick. The tone height depends on the trimming direction. The middle position is acoustically indicated by a longer signal.

After landing, switch off the receiver first and then the transmitter.



Attention!

Never turn the transmitter off when the model is still in operation. Signal interference can cause the model to carry out uncontrolled and unexpected servo movements or electric motor(s) may unexpectedly start to run at full power.

Then set the linkage rods on your model so that the trimming symbol in the display can be returned to the middle position and the model nonetheless continues to fly in a straight line. In the case of minimal deviations you have the option of slightly adjusting the sub-trimming.

16. Binding Function

To enable transmitter and receiver to work together, they must be bound by the same digital code. In the delivery state, transmitter and receiver are aligned with each other and can be used at once. The binding settings must be renewed mainly after a replacement of the transmitter or receiver or to remove any interferences.

Before you can bind the receiver to the transmitter, check if the transmitter works in the right digital code (see „RX setup“ in the system settings menu).

To perform the binding procedure, proceed as follows:

- Transmitter and receiver must be in direct proximity (distance approx. 50 cm).
- Switch off the transmitter.
- Disconnect any servos that may be connected from the receiver.
- Connect the enclosed programming plug (1) to the „B/VCC“ connection of the receiver.
- The power supply of the receiver (receiver battery or speed controller with BEC) is connected to any output of the receiver.
- Switch on the receiver. The receiver LED (2) starts to flash quickly.
- Press the binding button at the receiver (see also figure 1, item 13) and keep the button pressed.
- Switch on the transmitter with the on/off switch with the binding button pushed. The display briefly shows „RXBinding“ and, at correct binding, „RXBind OK“. Then the display switches to operating display.
- The LED in the receiver (2) now flashes slowly and the binding process is completed.
- Release the binding button at the transmitter.
- Switch off the receiver and then the transmitter.
- Remove the programming plug and connect the servos/controllers to the receiver again.
- Check the function of the system.

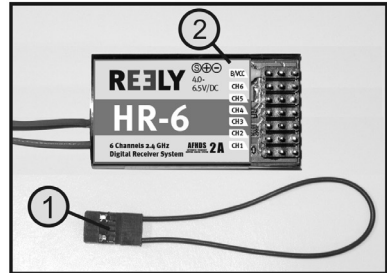

Figure 55



The receiver or the servos now must react to the control signals of the transmitter. If this is not the case, repeat binding or check the digital encoding of transmitter and receiver.

17. Maintenance and Care

Clean the exterior of the remote control with a soft, dry cloth or brush only. Never use abrasive cleaning agents or chemical solutions as these could damage the surfaces of the casings.

18. Declaration of Conformity (DOC)

Conrad Electronic SE, Klaus-Conrad-Straße 1, D-92240 Hirschau hereby declares that this product conforms to the 2014/53/EU directive.

Click on the following link to read the full text of the EU declaration of conformity: www.conrad.com/downloads

Enter the product item number in the search box. You can then download the EU declaration of conformity in the available languages.

19. Disposal

Product



This symbol must appear on any electrical and electronic equipment placed on the EU market. This symbol indicates that this device should not be disposed of as unsorted municipal waste at the end of its service life. Owners of WEEE (Waste from Electrical and Electronic Equipment) shall dispose of it separately from unsorted municipal waste. Spent batteries and accumulators, which are not enclosed by the WEEE, as well as lamps that can be removed from the WEEE in a non-destructive manner, must be removed by end users from the WEEE in a non-destructive manner before it is handed over to a collection point.

Distributors of electrical and electronic equipment are legally obliged to provide free take-back of waste. Conrad provides the following return options **free of charge** (more details on our website):

- in our Conrad offices
- at the Conrad collection points
- at the collection points of public waste management authorities or the collection points set up by manufacturers or distributors within the meaning of the ElektroG

End users are responsible for deleting personal data from the WEEE to be disposed of.

It should be noted that different obligations about the return or recycling of WEEE may apply in countries outside of Germany.

(Rechargeable) batteries

Remove batteries/rechargeable batteries, if any, and dispose of them separately from the product. According to the Battery Directive, end users are legally obliged to return all spent batteries/rechargeable batteries; they must not be disposed of in the normal household waste.



Batteries/rechargeable batteries containing hazardous substances are labelled with this symbol to indicate that disposal in household waste is forbidden. The abbreviations for heavy metals in batteries are: Cd = Cadmium, Hg = Mercury, Pb = Lead (name on (rechargeable) batteries, e.g. below the trash icon on the left).

Used (rechargeable) batteries can be returned to collection points in your municipality, our stores or wherever (rechargeable) batteries are sold. You thus fulfil your statutory obligations and contribute to environmental protection.

Batteries/rechargeable batteries that are disposed of should be protected against short circuit and their exposed terminals should be covered completely with insulating tape before disposal. Even empty batteries/rechargeable batteries can contain residual energy that may cause them to swell, burst, catch fire or explode in the event of a short circuit.

20. Troubleshooting

Even though the remote control system was built to the state of the art, there can still be interference or faults. For this reason, we would like to give you some information on how to deal with possible problems.

Problem	Remedy
Transmitter doesn't respond	<ul style="list-style-type: none">• Check the batteries in the transmitter.• Check the polarity of the batteries.• Check the battery contacts of the remote control.• Check the on/off switch.
The servos do not respond	<ul style="list-style-type: none">• Check the batteries in the receiver.• Test the switch cable.• Test the BEC function of the controller.• Check the polarity of the servo connector.• Check digital code.• Perform binding again.• For test purposes, change the receiver and bind again.
The servos vibrate	<ul style="list-style-type: none">• Check batteries in the remote control and the receiver.• Check connectors on the receiver.• Dry the receiver with a hair dryer in case it has gotten wet.• Check the receiver aerials for damage.• Reorient the receiver aerials in the model for test purposes.
One servo is humming	<ul style="list-style-type: none">• Check the batteries in the receiver.• Make sure the linkage rods run smoothly.• Operate the servo without the servo arm for test purposes.
The range of the system is very short	<ul style="list-style-type: none">• Check the batteries in the transmitter and receiver.• Check the receiver aerials for damage.• Reorient the receiver aerials in the model for test purposes.
Transmitter switches off on its own at once or after a short period	<ul style="list-style-type: none">• Check or replace the batteries in the transmitter.

21. Technical Data

a) Transmitter

Frequency range	2.408 - 2.475 GHz
Transmission power	<20 dBm (100mW)
Transmission range.....	max. 1000 m (open area)
Number of channels	6
Digital encoding	AFHDS / AFHDS2A (Automatic Frequency Hopping Digital System)
Operating voltage	6 V/DC via 4 type AA/mignon batteries
Signal output/input.....	PS/2 socket (PPM)
Dimensions (W x H x D)	174 x 187 x 80 mm
Weight without batteries	400 g

b) Receiver

Frequency range	2.4 GHz
Number of channels	6
Connector system.....	Futaba/Graupner JR
Operating voltage	4.5 - 6.5 V/DC
Dimensions (L x W x H).....	41 x 22 x 7.5 mm
Weight	7 g

This is a publication by Conrad Electronic SE, Klaus-Conrad-Str. 1, D-92240 Hirschau (www.conrad.com).

All rights including translation reserved. Reproduction by any method, e.g. photocopy, microfilming, or the capture in electronic data processing systems require the prior written approval by the editor. Reprinting, also in part, is prohibited. This publication represent the technical status at the time of printing.

© Copyright 2024 by Conrad Electronic SE.

1310037_v2_0124_02_dh_mh_en