

REVISION RECORD				
REV	ECN	DESCRIPTION	DRFT	DATE

- NOTES:
- 1.DIMENSION SHALL BE INTERPRETED PER ASME Y14.5-2009.
 2. RATED VOLTAGE :800V
 3. RATED CURRENT :6.3A
 4. INSULATION RESISTANCE: 5000M Ω/DC1000V
 5. WITHSTANDING VOLTAGE : AC2000V/1MIN
 6. TEMP.RANGE : -40° C~+105° C
 - 7.WIRE RANGE: 24~12AWG
 - 8.MAX.TORQUE VALUE: 5.10KGF.CM
 - 9.UNDIMENSIONED TOLERANCES:

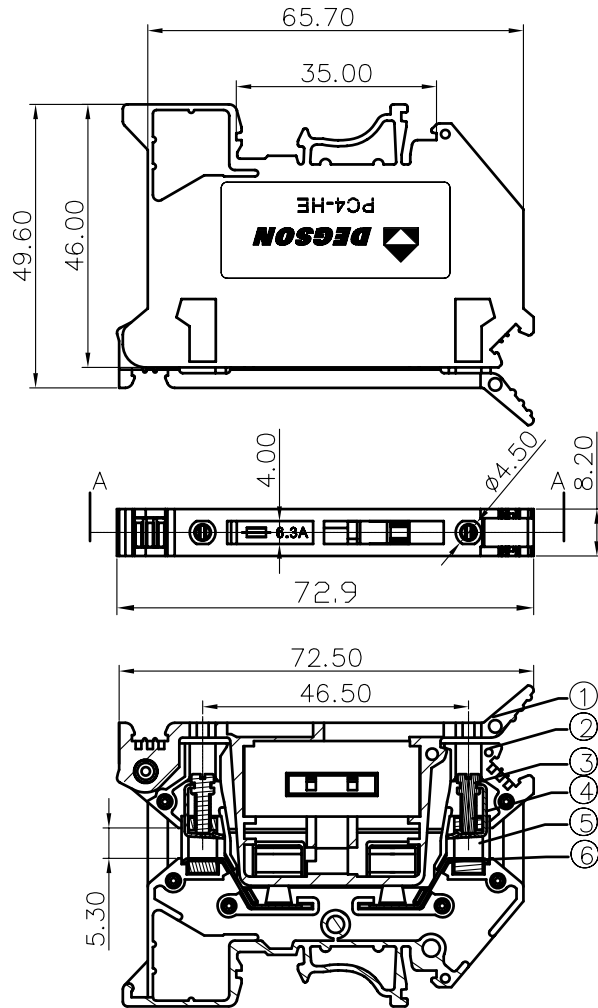

	Pitch range in mm		Nominal dimension range in mm				—		
	over 6 to 10	over 10 to 24	over 30 to 60	over 60 to 100	over 100 to 150	over 150			
to 6	±0.10	±0.15	±0.25	±0.2	±0.3	±0.5	±0.7	±1.0	0.05/10

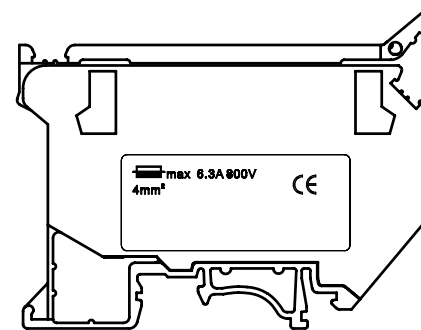

ITEM	NAME OF PART	NO. OF PART	Q"TY	MATERIAL	NOTES
2	PC4-HE-Body-Housing	6090A0Y01A(H)	1	PA66	UL94V-0
1	PC4-HE-Fuse-Housing	6090D0Y01A(H)	1	PA66	UL94V-0

4	6090B00020(H)	4027B00010(H)	2	Phosphor bronze	Ni plated
3	PC 4-Brass Cage	S000001460(H)	2	Brass	Ni plated
2	PC4-HE-Spring	X000000020(H)	2	Brass	Ni plated
3	PC4-HE-Screw	S000002710(H)	2	Brass	Ni plated

DETAILED LISTS		MATERIAL:		FINISH:		PART NO.:		NAME:	
TOLERANCES EXCEPT AS NOTED		.X ±		.X' ±		.XX ±		.XX' ±	
.XX ±		.XXX ±		.XXX' ±		.XXX' ±		PC4-HE-01P-1Y-00A(H)	
ANGLES ± 1°		APPD:		TITLE: ASSEMBLY DRAWING		REV		T1	
THIRD ANGLE PROJECTION		CHKD:		DRAWING NO.: PC4-HE-E01		DO NOT SCALE DRAWING		SCALE N/A SHEET 1/1	
		DRFT: LIN 09/30/07"							