

REVISION RECORD				
REV	ECN	DESCRIPTION	DRFT	DATE

NOTES:

- 1.DIMENSION SHALL BE INTERPRETED PER ASME Y14.5-2009.
- 2.PITCH:3.5MM ,POLES:N=2-22P
- 3.UL:300V/8A
- 4.VDE:

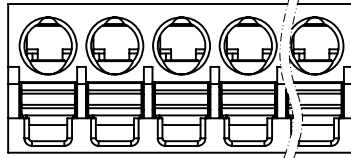

POLLUTION DEGREE	2
OVERVOLTAGE CATEGORY	II
RATED IMPULSE VOLTAGE(KV)	2.5KV
RATED VOLTAGE(V)	250V
RATED CURRENT(A)	8A

PITCH RANGE IN MM		NOMINAL DIMENSION RANGE IN MM				
TO	OVER	TO	OVER	OVER	OVER	
6	10	10	30	60	100	150
10	24	30	60	100	150	150
±0.10	±0.15	±0.25	±0.20	±0.30	±0.50	±0.70
						±1.00
						0.05/10

- 5.LOWER LIMIT TEMPERATURE:-40°C
- 6.UPPER LIMIT TEMPERATURE:+105°C
- 7.WIRE RANGE: 28AWG~16AWG,0.2MM²~1.0MM²
- 8.STRIPPING LENGTH:10MM
- 9.UNDIMENSIONED TOLERANCES:

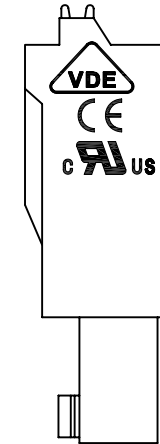
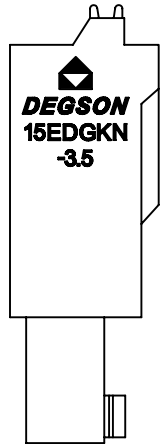
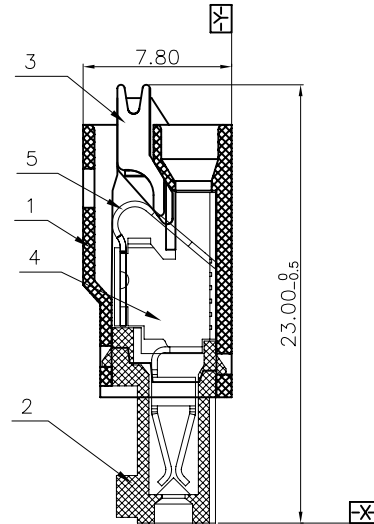
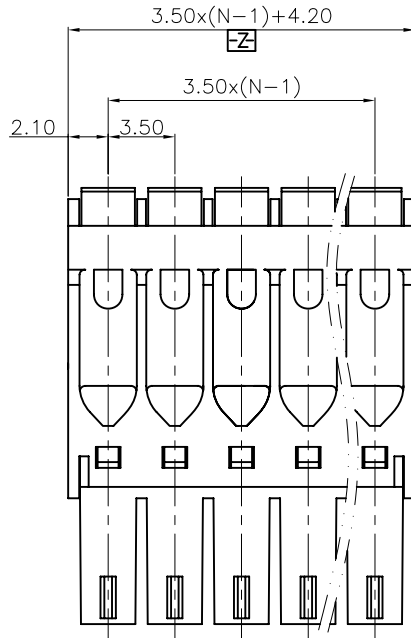

ITEM	NAME OF PART	NO. OF PART	Q'TY	MATERIAL	NOTES
5	15EDGKN-3.5-Spring	X000001910(H)	XX	Steel	
4	15EDGKN-3.5-Clamp	1103B00010(H)	XX	Bronze	Sn Plated
3	15EDGKN-3.5-Buttom	1103D0501A(H)	XX	POM	UL94HB
2	15EDGKN-3.5-Cover	1103CYYXXA(H)	1	PA66	UL94V-0
1	15EDGKNG-3.5-Housing	1103AYYXXA(H)	1	PA66	UL94V-0

MM (INCH)		MATERIAL:	DEGSON®			
TOLERANCES EXCEPT AS NOTED		FINISH:	NAME: 15EDGKN-3.5-XXP-1Y-00A(H)			
.X ±	.X' ±	PART NO.:				
.XX ±	.XX' ±	APPD:	TITLE: ASSEMBLY DRAWING		REV	TO
.XXX ±	.XXX' ±	CHKD:	DRAWING NO.: 15EDGKN-3.5-E01			
ANGLES ± 1°		DRFT: XLM 10/16/13"	DO NOT SCALE DRAWING	SCALE	N/A	SHEET 1/1
THIRD ANGLE PROJECTION						