

**ENERGIZER X22**

**9V**

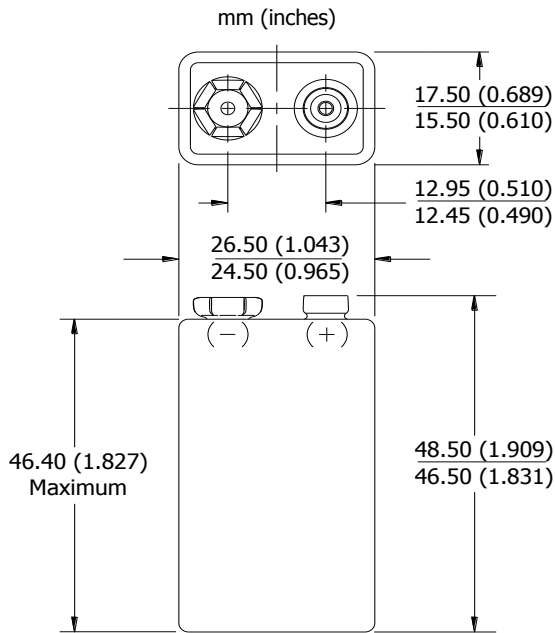

**Industry Standard Dimensions**



**Specifications**

<b>Classification:</b>	Alkaline
<b>Chemical System:</b>	Zinc-Manganese Dioxide (Zn/MnO <sub>2</sub> ) No added mercury or cadmium
<b>Designation:</b>	IEC-6LR61
<b>Nominal Voltage:</b>	9.0 volts
<b>Operating Temp:</b>	-18°C to 55°C
<b>Typical Weight:</b>	45.0 grams (1.58 oz.)
<b>Typical Volume:</b>	21.1 cubic centimeters
<b>Jacket:</b>	Plastic
<b>Shelf Life:</b>	5 years at 21°C
<b>Terminal:</b>	Miniature Snap

**Continuous Discharge**

to 4.8 volts at 21°C

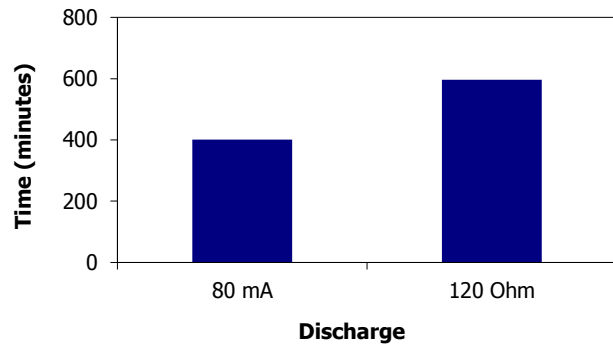

**Industry Standard Tests (21°C)**

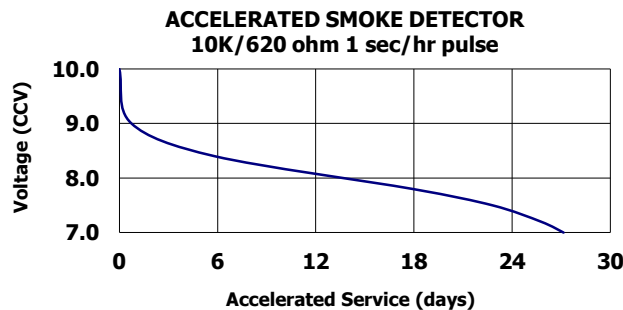
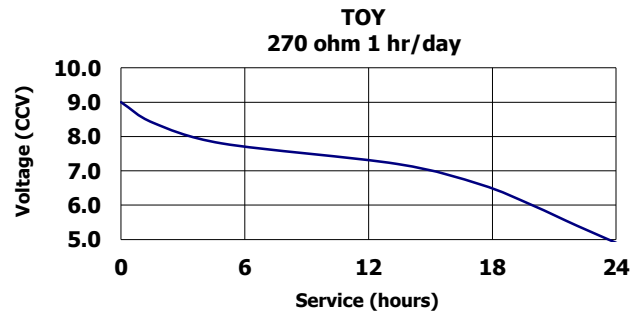
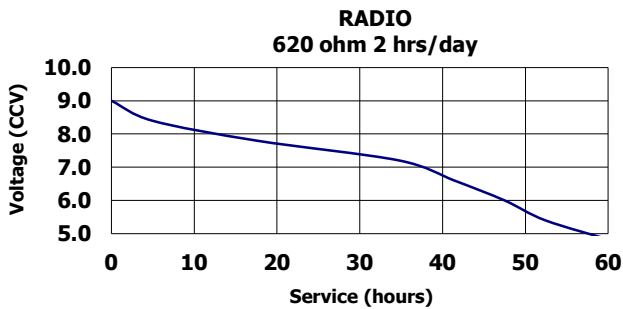

**Important Notice**

This datasheet contains typical information specific to products manufactured at the time of its publication.  
©Energizer Holdings, Inc. - Contents herein do not constitute a warranty.