

SPECIFICATION



LED STRIP SERIES

Art.Nr.:1205-70

LED STRIP SERIES

Art.Nr.:1205-70

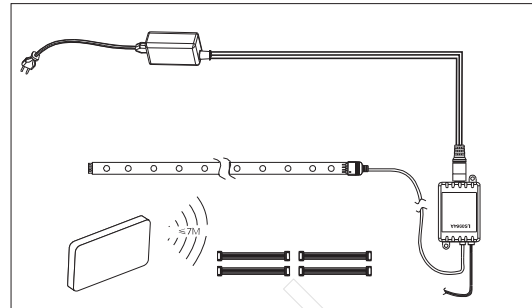

FEATURES:

- No UV or IR radiation
- Super thin , and easy to install
- High brightness 5050 LED
- LED QTY: 300 PCS
- 50000 hours long life span
- Low temperature rising, less than 30°C
- Less than 5% light decay in 10,000 hours testing
- 120° Beaming Angle
- Colour: RGB

- 8 lines
- IR Remote control.
- Dimming function.

APPLICATIONS:

- Illuminated signs
- For any shape of channel letters

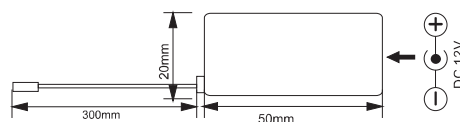
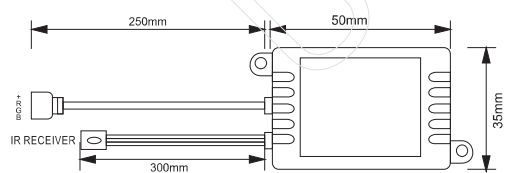
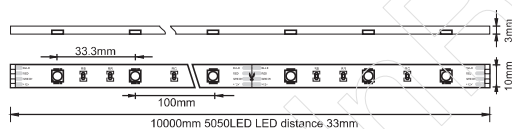

- All the size date above is in mm
 - Tolerance for the size date is ± 0.2 mm

SPECIFICATIONS:

- Input Voltage Transformer
 220-240V/50-60 Hz
- Max. Power 60Watt

- Input Voltage LED Stripe DC12.5V
- Operating Temperatur -20°C - 45°C
- Storage Temperatur -25°C - 85°C

- Tolerance of all the optical data is $\pm 15\%$
 - Please don't install in flammable, explosive or corrosive circumstances.

LED STRIP SERIES

Installation:

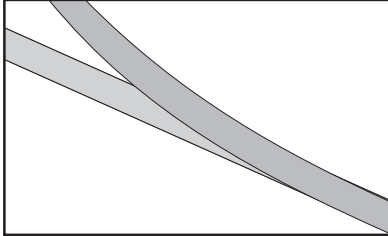

1, Rip PE adhesive tape one the back of the product, then stick to the objects where you want.

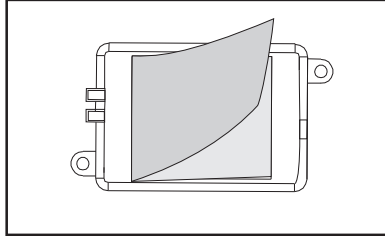

2, Rip PE adhesive tape one the back of the product, then stick to the objects where you want.

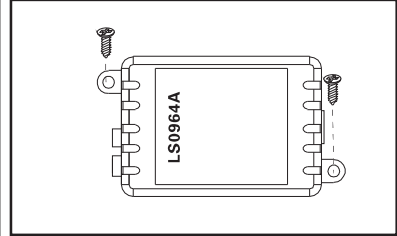

3, Connect the controller with special connector.

Connection method:

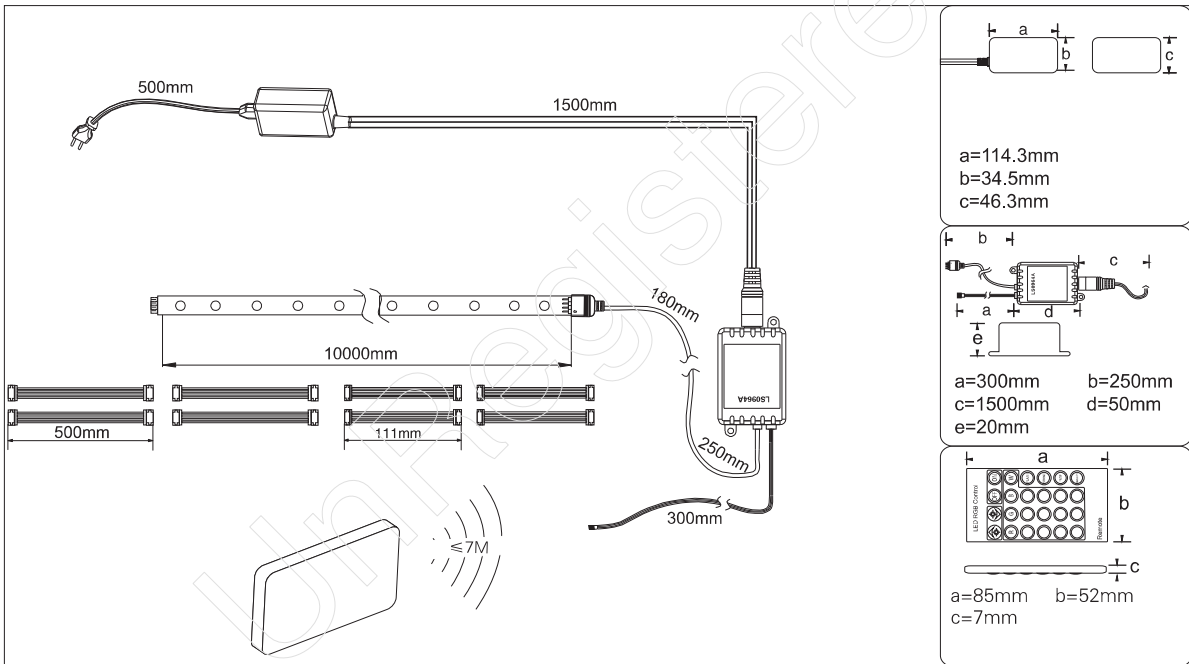

Fix the controller with screws.

Terminal:

