



WAGO-I/O-SYSTEM 750 **PFC200 CS 2ETH RS** **750-8202(/xxx-xxx)** **PLC - PFC200 Controller**

Version 1.1.0, valid from SW-Version 02.02.12(03)

WAGO®

© 2014 by WAGO Kontakttechnik GmbH & Co. KG
All rights reserved.

WAGO Kontakttechnik GmbH & Co. KG

Hansastraße 27
D-32423 Minden

Phone: +49 (0) 571/8 87 – 0
Fax: +49 (0) 571/8 87 – 1 69

E-Mail: info@wago.com

Web: <http://www.wago.com>

Technical Support

Phone: +49 (0) 571/8 87 – 5 55
Fax: +49 (0) 571/8 87 – 85 55

E-Mail: support@wago.com

Every conceivable measure has been taken to ensure the accuracy and completeness of this documentation. However, as errors can never be fully excluded, we always appreciate any information or suggestions for improving the documentation.

E-Mail: documentation@wago.com

We wish to point out that the software and hardware terms as well as the trademarks of companies used and/or mentioned in the present manual are generally protected by trademark or patent.

Table of Contents

| | | |
|----------|---|-----------|
| 1 | Notes about this Documentation..... | 11 |
| 1.1 | Validity of this Documentation..... | 11 |
| 1.2 | Copyright..... | 11 |
| 1.3 | Symbols..... | 12 |
| 1.4 | Number Notation..... | 14 |
| 1.5 | Font Conventions..... | 14 |
| 2 | Important Notes | 15 |
| 2.1 | Legal Bases | 15 |
| 2.1.1 | Subject to Changes | 15 |
| 2.1.2 | Personnel Qualifications..... | 15 |
| 2.1.3 | Use of the WAGO-I/O-SYSTEM 750 in Compliance with Underlying Provisions | 15 |
| 2.1.4 | Technical Condition of Specified Devices..... | 16 |
| 2.2 | Safety Advice (Precautions)..... | 17 |
| 2.3 | Special Use Conditions for ETHERNET Devices..... | 19 |
| 3 | Device Description | 20 |
| 3.1 | View | 23 |
| 3.2 | Connectors..... | 25 |
| 3.2.1 | Data Contacts/Internal Bus..... | 25 |
| 3.2.2 | Power Jumper Contacts/Field Supply | 26 |
| 3.2.3 | CAGE CLAMP® Connectors | 27 |
| 3.2.4 | Service Interface..... | 28 |
| 3.2.5 | Network Connections – X1, X2 | 29 |
| 3.2.6 | RS-232/RS-485 – X3 Communication Connection | 30 |
| 3.2.6.1 | Operating as an RS-232 Interface..... | 31 |
| 3.2.6.2 | Operating as an RS-485 Interface..... | 32 |
| 3.3 | Display Elements | 33 |
| 3.3.1 | Power Supply Indicating Elements | 33 |
| 3.3.2 | Fieldbus/System Indicating Elements | 34 |
| 3.3.3 | Memory Card Indicating Elements | 35 |
| 3.3.4 | Network Indicating Elements..... | 36 |
| 3.4 | Operating Elements..... | 37 |
| 3.4.1 | Operating Mode Switch..... | 37 |
| 3.4.2 | Reset Button | 38 |
| 3.5 | Slot for Memory Card | 39 |
| 3.6 | Schematic Diagram | 40 |
| 3.7 | Technical Data | 41 |
| 3.7.1 | Device Data | 41 |
| 3.7.2 | System Data..... | 41 |
| 3.7.3 | Power supply | 41 |
| 3.7.4 | Clock..... | 41 |
| 3.7.5 | Programming | 42 |
| 3.7.6 | Internal data bus | 42 |
| 3.7.7 | ETHERNET | 42 |
| 3.7.8 | Serial interface..... | 42 |
| 3.7.9 | Connection Type | 43 |

| | | |
|----------|--|-----------|
| 3.7.10 | Climatic Environmental Conditions | 43 |
| 3.8 | Approvals | 44 |
| 3.9 | Standards and Guidelines | 44 |
| 4 | Function Description | 45 |
| 4.1 | Network Configuration | 45 |
| 4.1.1 | Operation in Switch Mode | 45 |
| 4.1.2 | Operation with Separate Network Interfaces | 45 |
| 5 | Mounting..... | 46 |
| 5.1 | Installation Position | 46 |
| 5.2 | Overall Configuration | 46 |
| 5.3 | Mounting onto Carrier Rail | 48 |
| 5.3.1 | Carrier Rail Properties | 48 |
| 5.3.2 | WAGO DIN Rail | 49 |
| 5.4 | Spacing | 49 |
| 5.5 | Mounting Sequence | 50 |
| 5.6 | Inserting Devices | 51 |
| 5.6.1 | Inserting the Fieldbus Coupler/Controller | 51 |
| 5.6.2 | Inserting the I/O Module | 52 |
| 6 | Connect Devices | 53 |
| 6.1 | Connecting a Conductor to the CAGE CLAMP® | 53 |
| 6.2 | Power Supply Concept | 55 |
| 6.2.1 | Supplementary Power Supply Regulations | 55 |
| 7 | Commissioning | 57 |
| 7.1 | Switching On the Controller | 57 |
| 7.2 | Determining the IP Address of the Host PC | 58 |
| 7.3 | Setting an IP Address | 59 |
| 7.3.1 | Assigning an IP Address using DHCP | 60 |
| 7.3.2 | Changing an IP Address using the “CBM” Configuration Tool via the Serial Interface..... | 61 |
| 7.3.3 | Changing an IP Address using “WAGO Ethernet Settings” | 64 |
| 7.4 | Testing the Network Connection | 66 |
| 7.5 | Shutdown/Restart | 67 |
| 7.6 | Initiating Reset Functions | 68 |
| 7.6.1 | Warm Start Reset..... | 68 |
| 7.6.2 | Cold Start Reset..... | 68 |
| 7.6.3 | Software Reset..... | 68 |
| 7.6.4 | Setting a Fixed IP Address | 68 |
| 7.6.5 | Factory Reset..... | 69 |
| 7.7 | Users and Passwords | 70 |
| 7.7.1 | Services and Users..... | 70 |
| 7.7.2 | WBM Group..... | 71 |
| 7.7.3 | Linux User Group..... | 71 |
| 7.7.4 | SNMP User Group | 71 |
| 7.8 | Configuration | 72 |
| 7.8.1 | Configuration using Web-Based Management (WBM)..... | 73 |
| 7.8.1.1 | WBM User Administration..... | 74 |
| 7.8.1.2 | General Information about the Page | 76 |
| 7.8.1.3 | “Status Information” Page | 78 |

| | | |
|------------|--|----|
| 7.8.1.3.1 | “Controller Details” Group | 78 |
| 7.8.1.3.2 | “Network Details (Xn)” Group(s) | 78 |
| 7.8.1.4 | “CODESYS Configuration” Page | 79 |
| 7.8.1.4.1 | “General Configuration” Group | 79 |
| 7.8.1.5 | “CODESYS Information” Page | 80 |
| 7.8.1.5.1 | “CODESYS” Group | 80 |
| 7.8.1.5.2 | “Project Details” Group | 80 |
| 7.8.1.5.3 | “Task n” Group(s) | 80 |
| 7.8.1.6 | “CODESYS WebVisu” Page | 82 |
| 7.8.1.6.1 | “Webserver Configuration” Group | 82 |
| 7.8.1.7 | “Configuration of Network Parameters” Page” | 83 |
| 7.8.1.7.1 | “Hostname” Group | 83 |
| 7.8.1.7.2 | “Domain Name” Group | 83 |
| 7.8.1.8 | “TCP/IP Configuration” Page | 84 |
| 7.8.1.8.1 | “Switch Configuration” Group | 84 |
| 7.8.1.8.2 | “IP Address (Xn)” Group(s) | 84 |
| 7.8.1.8.3 | “Default Gateway” Group | 85 |
| 7.8.1.8.4 | “DNS Server” Group | 85 |
| 7.8.1.9 | “Configuration of ETHERNET Parameters” Page | 86 |
| 7.8.1.9.1 | “Interface Xn” Groups | 86 |
| 7.8.1.10 | “Configuration of Time and Date” Page | 87 |
| 7.8.1.10.1 | “Date on Device” Group | 87 |
| 7.8.1.10.2 | “Time on Device” Group | 87 |
| 7.8.1.10.3 | “Time Zone” Group | 88 |
| 7.8.1.10.4 | “TZ String” Group | 88 |
| 7.8.1.11 | “Configuration of the Users for the Web-based Management” Page | 89 |
| 7.8.1.11.1 | “Change Password for Selected User” Group | 89 |
| 7.8.1.12 | “Create Bootable Image” Page | 90 |
| 7.8.1.12.1 | “Create Bootable Image from Active Partition (<Active Partition>” Group | 90 |
| 7.8.1.13 | “Configuration of Serial Interface RS232” Page | 91 |
| 7.8.1.13.1 | “Serial Interface Assigned to” Group | 91 |
| 7.8.1.13.2 | “Assign Owner of Serial Interface (Active after Next Controller Reboot)” Group | 91 |
| 7.8.1.14 | “Reboot Controller” Page | 92 |
| 7.8.1.14.1 | “Reboot Controller” Group | 92 |
| 7.8.1.15 | “Firmware Back-up” Page | 93 |
| 7.8.1.16 | “Firmware Restore” Page | 94 |
| 7.8.1.17 | “System Partition” Page | 95 |
| 7.8.1.17.1 | “Current Active Partition” Group | 95 |
| 7.8.1.17.2 | “Set Inactive Partition Active” Group | 95 |
| 7.8.1.18 | “Mass Storage” Page | 96 |
| 7.8.1.18.1 | “<Device Name>” Group(s) | 96 |
| 7.8.1.18.2 | “<Device Name> - FAT Format” Group(s) | 96 |
| 7.8.1.19 | “Software Uploads” Page | 97 |
| 7.8.1.19.1 | “Upload New Software” Group | 97 |
| 7.8.1.19.2 | “Activate New Software” Group | 97 |
| 7.8.1.20 | “Configuration of Network Services” Page | 98 |
| 7.8.1.20.1 | “Telnet” Group | 98 |
| 7.8.1.20.2 | “FTP” Group | 98 |

| | | |
|------------|---|------------|
| 7.8.1.20.3 | “FTPS” Group..... | 98 |
| 7.8.1.20.4 | “HTTP” Group..... | 98 |
| 7.8.1.20.5 | “HTTPS” Group..... | 98 |
| 7.8.1.21 | “Configuration of NTP Client” Page..... | 99 |
| 7.8.1.21.1 | “NTP Client” Group..... | 99 |
| 7.8.1.22 | “Configuration of the CODESYS Services” Page..... | 100 |
| 7.8.1.22.1 | “CODESYS Webserver” Group | 100 |
| 7.8.1.22.2 | “Communication” Group | 100 |
| 7.8.1.22.3 | “Port Authentication” Group | 100 |
| 7.8.1.22.4 | “Port Authentication Password” Group | 100 |
| 7.8.1.23 | “SSH Client Settings” Page..... | 101 |
| 7.8.1.23.1 | “SSH Client” Group..... | 101 |
| 7.8.1.24 | “TFTP Server” Page | 102 |
| 7.8.1.24.1 | “TFTP Server” Group | 102 |
| 7.8.1.25 | “Configuration of SNMP parameter” Page | 103 |
| 7.8.1.25.1 | “General SNMP Configuration” Group..... | 103 |
| 7.8.1.26 | “Configuration of SNMP Parameter” Page..... | 104 |
| 7.8.1.26.1 | “SNMP v1/v2c Manager Configuration” Group | 104 |
| 7.8.1.26.2 | “Actually Configured Trap Receivers” Group(s) | 104 |
| 7.8.1.26.3 | “Trap Receiver n” Group(s)..... | 105 |
| 7.8.1.26.4 | “Add new Trap Receiver” Group..... | 105 |
| 7.8.1.27 | “Configuration of SNMP v3 Users” Page | 106 |
| 7.8.1.27.1 | “Actually Configured v3 Users” Group(s)..... | 106 |
| 7.8.1.27.2 | “v3 User n” Group(s) | 106 |
| 7.8.1.27.3 | “Add New v3 User” Group..... | 107 |
| 7.8.1.28 | “Diagnostic Information” Page..... | 108 |
| 7.8.2 | Configuration using a Terminal Program (CBM) | 109 |
| 7.8.3 | Configuration using “WAGO ETHERNET Settings” | 110 |
| 7.8.3.1 | Identification Tab..... | 112 |
| 7.8.3.2 | Network Tab | 113 |
| 7.8.3.3 | Protocol Tab..... | 115 |
| 7.8.3.4 | Status Tab | 116 |
| 8 | Run-time System CODESYS 2.3 | 117 |
| 8.1 | Installing the CODESYS 2.3 Programming System..... | 117 |
| 8.2 | First Program with CODESYS 2.3 | 117 |
| 8.2.1 | Start the CODESYS Programming System..... | 117 |
| 8.2.2 | Creating a Project and Selecting a Target System..... | 117 |
| 8.2.3 | Creating the PLC Configuration..... | 119 |
| 8.2.4 | Editing the Program Function Block..... | 125 |
| 8.2.5 | Loading and Running the PLC Program in the Fieldbus Controller (ETHERNET)..... | 128 |
| 8.2.6 | Creating a Boot Project | 130 |
| 8.3 | Syntax of Logical Addresses..... | 130 |
| 8.4 | Creating Tasks..... | 131 |
| 8.4.1 | Cyclic Tasks | 134 |
| 8.4.2 | Freewheeling Tasks | 135 |
| 8.5 | System Events | 135 |
| 8.5.1 | Creating an Event Handler | 138 |
| 8.6 | Process Images | 140 |
| 8.6.1 | Process Images for I/O Modules Connected to the Controller..... | 142 |

| | | |
|-----------|--|------------|
| 8.6.2 | Process Image for Slaves Connected to the Fieldbus..... | 143 |
| 8.7 | Access to Process Images of the Input and Output Data via CODESYS 2.3..... | 143 |
| 8.8 | Addressing Example..... | 144 |
| 8.9 | Internal Data Bus Synchronization..... | 145 |
| 8.9.1 | Case 1: CODESYS Task Interval Set Smaller than the I/O Module Cycle..... | 146 |
| 8.9.2 | Case 2: CODESYS Task Interval Smaller than Twice the Internal Data Bus Cycle..... | 147 |
| 8.9.3 | Case 3: CODESYS Task Interval Greater than Twice the Internal Data Bus Cycle..... | 148 |
| 8.9.4 | Case 4: CODESYS Task Interval Greater than 10 ms..... | 149 |
| 8.9.5 | Internal Data Bus Configuration..... | 150 |
| 8.9.5.1 | Effect of Update Mode on CODESYS Tasks..... | 151 |
| 8.9.5.1.1 | Asynchronous Update Mode..... | 151 |
| 8.9.5.1.2 | Synchronous Update Mode..... | 152 |
| 8.10 | Memory Settings in CODESYS..... | 152 |
| 8.10.1 | Program Memory..... | 152 |
| 8.10.2 | Data Memory and Function Block Limitation..... | 153 |
| 8.10.3 | Remanent Memory..... | 154 |
| 8.11 | CODESYS Visualization..... | 155 |
| 8.11.1 | Limits of CODESYS Visualization..... | 158 |
| 8.11.2 | Eliminating Errors in CODESYS Web Visualization..... | 160 |
| 8.11.3 | FAQs about CODESYS Web Visualization..... | 161 |
| 9 | MODBUS..... | 163 |
| 9.1 | General..... | 163 |
| 9.2 | Features..... | 163 |
| 9.3 | Configuration..... | 164 |
| 9.3.1 | MODBUS Settings..... | 165 |
| 9.3.2 | MODBUS TCP Settings..... | 166 |
| 9.3.3 | MODBUS UDP Settings..... | 166 |
| 9.3.4 | MODBUS RTU Settings..... | 167 |
| 9.4 | Data Exchange..... | 169 |
| 9.4.1 | Process Image..... | 170 |
| 9.4.2 | Flag Area..... | 171 |
| 9.4.3 | MODBUS Registers..... | 172 |
| 9.4.4 | MODBUS Mapping..... | 172 |
| 9.4.4.1 | MODBUS Mapping for Write Bit Services FC1, FC2..... | 172 |
| 9.4.4.2 | MODBUS Mapping for Write Bit Services FC5, FC15..... | 173 |
| 9.4.4.3 | MODBUS Mapping for Read Register Services FC3, FC4, FC23..... | 174 |
| 9.4.4.4 | MODBUS Mapping for Write Register Services FC6, FC16, FC22, FC23..... | 176 |
| 9.5 | WAGO MODBUS Register..... | 178 |
| 9.5.1 | Process Image Properties..... | 179 |
| 9.5.1.1 | Register 0x1022 – Number of Registers in the MODBUS Input Process Image..... | 179 |
| 9.5.1.2 | Register 0x1023 – Number of Registers in the MODBUS Output Process Image..... | 179 |
| 9.5.1.3 | Register 0x1024 – Number of Bits in the MODBUS Input Process Image..... | 179 |

| | | |
|-----------|---|------------|
| 9.5.1.4 | Register 0x1025 – Number of Bits in the MODBUS Output Process Image | 179 |
| 9.5.2 | Network Configuration..... | 180 |
| 9.5.2.1 | Register 0x1028 – IP Configuration | 180 |
| 9.5.2.2 | Register 0x102A – Number of Established TCP Connections.... | 180 |
| 9.5.2.3 | Register 0x1030 – MODBUS TCP Socket Timeout | 180 |
| 9.5.2.4 | Register 0x1031 – MAC Address for ETHERNET-Interface 1 (eth0)..... | 180 |
| 9.5.2.5 | Register 0x1037 - MODBUS TCP Response Delay | 180 |
| 9.5.3 | PLC Status Register..... | 181 |
| 9.5.4 | MODBUS Watchdog..... | 181 |
| 9.5.4.1 | Register 0x1100 – Watchdog Command..... | 181 |
| 9.5.4.2 | Register 0x1101 – Watchdog Status..... | 183 |
| 9.5.4.3 | Register 0x1102 – Watchdog Timeout | 183 |
| 9.5.4.4 | Register 0x1103 – Watchdog Config | 184 |
| 9.5.5 | MODBUS Constants Register..... | 184 |
| 9.5.6 | Electronic Nameplate | 185 |
| 9.5.6.1 | Register 0x2010 – Revision (Firmware Index) | 185 |
| 9.5.6.2 | Register 0x2011 – Series Designator..... | 185 |
| 9.5.6.3 | Register 0x2012 – Device ID | 185 |
| 9.5.6.4 | Register 0x2013 – Major Firmware Version..... | 185 |
| 9.5.6.5 | Register 0x2014 – Minor Firmware Version..... | 185 |
| 9.5.6.6 | Register 0x2015 – MBS Version..... | 185 |
| 9.6 | Diagnostics | 186 |
| 9.6.1 | Diagnostics for the MODBUS Master | 186 |
| 9.6.2 | Diagnostics for the Runtime System | 186 |
| 9.6.3 | Diagnostics for the Error Server..... | 186 |
| 10 | Diagnostics | 189 |
| 10.1 | Operating and Status Messages..... | 189 |
| 10.1.1 | Power Supply Indicating Elements | 189 |
| 10.1.2 | Fieldbus/System Indicating Elements | 190 |
| 10.2 | Diagnostics Messages (I/O LED)..... | 193 |
| 10.2.1 | Flashing Sequence..... | 193 |
| 10.2.2 | Example of a Diagnostics Message Indicated by a Blink Code..... | 195 |
| 10.2.3 | Meaning of Blink Codes and Procedures for Troubleshooting..... | 196 |
| 11 | Service | 202 |
| 11.1 | Inserting and Removing the Memory Card..... | 202 |
| 11.1.1 | Inserting the Memory Card | 202 |
| 11.1.2 | Removing the Memory Card..... | 202 |
| 12 | Removal | 204 |
| 12.1 | Removing Devices | 204 |
| 12.1.1 | Removing the Fieldbus Coupler/Controller | 204 |
| 12.1.2 | Removing the I/O Module..... | 205 |
| 13 | Appendix..... | 206 |
| 13.1 | Structure of Process Data for the I/O Modules | 206 |
| 13.1.1 | Digital Input Modules..... | 207 |
| 13.1.1.1 | 1 Channel Digital Input Module with Diagnostics | 207 |
| 13.1.1.2 | 2 Channel Digital Input Modules | 207 |

| | | |
|-----------|---|-----|
| 13.1.1.3 | 2 Channel Digital Input Module with Diagnostics | 207 |
| 13.1.1.4 | 2 Channel Digital Input Module with Diagnostics and Output Process Data..... | 208 |
| 13.1.1.5 | 4 Channel Digital Input Modules | 208 |
| 13.1.1.6 | 8 Channel Digital Input Modules | 208 |
| 13.1.1.7 | 8 Channel Digital Input Module PTC with Diagnostics and Output Process Data..... | 209 |
| 13.1.1.8 | 16 Channel Digital Input Modules | 209 |
| 13.1.2 | Digital Output Modules..... | 210 |
| 13.1.2.1 | 1 Channel Digital Output Module with Input Process Data | 210 |
| 13.1.2.2 | 2 Channel Digital Output Modules..... | 210 |
| 13.1.2.3 | 2 Channel Digital Input Modules with Diagnostics and Input Process Data..... | 211 |
| 13.1.2.4 | 4 Channel Digital Output Modules..... | 212 |
| 13.1.2.5 | 4 Channel Digital Output Modules with Diagnostics and Input Process Data..... | 212 |
| 13.1.2.6 | 8 Channel Digital Output Module | 212 |
| 13.1.2.7 | 8 Channel Digital Output Modules with Diagnostics and Input Process Data..... | 213 |
| 13.1.2.8 | 16 Channel Digital Output Modules..... | 213 |
| 13.1.2.9 | 8 Channel Digital Input/Output Modules | 214 |
| 13.1.3 | Analog Input Modules..... | 215 |
| 13.1.3.1 | 1 Channel Analog Input Modules..... | 215 |
| 13.1.3.2 | 2 Channel Analog Input Modules..... | 215 |
| 13.1.3.3 | 4 Channel Analog Input Modules..... | 216 |
| 13.1.3.4 | 3-Phase Power Measurement Module | 217 |
| 13.1.3.5 | 8 Channel Analog Input Modules..... | 217 |
| 13.1.4 | Analog Output Modules | 218 |
| 13.1.4.1 | 2 Channel Analog Output Modules | 218 |
| 13.1.4.2 | 4 Channel Analog Output Modules | 218 |
| 13.1.5 | Specialty Modules | 219 |
| 13.1.5.1 | Counter Modules | 219 |
| 13.1.5.2 | Pulse Width Modules..... | 221 |
| 13.1.5.3 | Serial Interface Modules with alternative Data Format..... | 221 |
| 13.1.5.4 | Serial Interface Modules with Standard Data Format | 222 |
| 13.1.5.5 | Data Exchange Module..... | 222 |
| 13.1.5.6 | SSI Transmitter Interface Modules..... | 222 |
| 13.1.5.7 | Incremental Encoder Interface Modules..... | 223 |
| 13.1.5.8 | DC-Drive Controller | 225 |
| 13.1.5.9 | Stepper Controller..... | 226 |
| 13.1.5.10 | RTC Module | 227 |
| 13.1.5.11 | DALI/DSI Master Module..... | 227 |
| 13.1.5.12 | DALI Multi-Master Module | 228 |
| 13.1.5.13 | LON [®] FTT Module..... | 230 |
| 13.1.5.14 | EnOcean Radio Receiver..... | 230 |
| 13.1.5.15 | MP Bus Master Module..... | 230 |
| 13.1.5.16 | Bluetooth [®] RF-Transceiver..... | 231 |
| 13.1.5.17 | Vibration Velocity/Bearing Condition Monitoring VIB I/O | 232 |
| 13.1.5.18 | KNX/EIB/TP1 Module | 232 |
| 13.1.5.19 | AS-interface Master Module | 233 |

| | | |
|------------------------------|--------------------------------------|------------|
| 13.1.6 | System Modules | 235 |
| 13.1.6.1 | System Modules with Diagnostics..... | 235 |
| 13.1.6.2 | Binary Space Module | 235 |
| 13.2 | CODESYS Libraries | 236 |
| 13.2.1 | General Libraries | 236 |
| 13.2.1.1 | CODESYS System Libraries | 236 |
| 13.2.1.2 | SysLibCom.lib | 237 |
| 13.2.1.3 | SysLibFile.lib..... | 237 |
| 13.2.1.4 | SysLibFileAsync.lib | 238 |
| 13.2.1.5 | SysLibRtc.lib | 238 |
| 13.2.1.6 | BusDiag.lib | 239 |
| 13.2.1.7 | mod_com.lib | 239 |
| 13.2.1.8 | SerComm.lib | 239 |
| 13.2.1.9 | WagoConfigToolLIB.lib | 240 |
| 13.2.1.10 | WagoLibCpuUsage.lib | 255 |
| 13.2.1.11 | WagoLibDiagnosticIDs.lib | 255 |
| 13.2.1.12 | WagoLibLed.lib | 256 |
| 13.2.1.13 | WagoLibNetSnmp.lib | 256 |
| 13.2.1.14 | WagoLibNetSnmpManager.lib..... | 256 |
| 13.2.1.15 | WagoLibSSL.lib | 257 |
| 13.2.1.16 | WagoLibTerminalDiag.lib..... | 257 |
| List of Figures | | 258 |
| List of Tables..... | | 261 |

1 Notes about this Documentation

Note



Always retain this documentation!

This documentation is part of the product. Therefore, retain the documentation during the entire service life of the product. Pass on the documentation to any subsequent user. In addition, ensure that any supplement to this documentation is included, if necessary.

1.1 Validity of this Documentation

This documentation is only applicable to the controller “PFC200 CS 2ETH RS” (750-8202) and the variants listed in the table below.

Table 1: Variants

| Item Number/Variant | Designation |
|---------------------|---------------------|
| 750-8202 | PFC200 CS 2ETH RS |
| 750-8202/025-000 | PFC200 CS 2ETH RS/T |

Note



Documentation Validity for Variants

Unless otherwise indicated, the information given in this documentation applies to listed variants.

This documentation is only applicable from SW-Version 02.02.12(03).

1.2 Copyright

This Manual, including all figures and illustrations, is copyright-protected. Any further use of this Manual by third parties that violate pertinent copyright provisions is prohibited. Reproduction, translation, electronic and phototechnical filing/archiving (e.g., photocopying) as well as any amendments require the written consent of WAGO Kontakttechnik GmbH & Co. KG, Minden, Germany. Non-observance will involve the right to assert damage claims.

1.3 Symbols

DANGER

Personal Injury!

Indicates a high-risk, imminently hazardous situation which, if not avoided, will result in death or serious injury.

DANGER



Personal Injury Caused by Electric Current!

Indicates a high-risk, imminently hazardous situation which, if not avoided, will result in death or serious injury.

WARNING

Personal Injury!

Indicates a moderate-risk, potentially hazardous situation which, if not avoided, could result in death or serious injury.

CAUTION

Personal Injury!

Indicates a low-risk, potentially hazardous situation which, if not avoided, may result in minor or moderate injury.

NOTICE

Damage to Property!

Indicates a potentially hazardous situation which, if not avoided, may result in damage to property.

NOTICE



Damage to Property Caused by Electrostatic Discharge (ESD)!

Indicates a potentially hazardous situation which, if not avoided, may result in damage to property.

Note



Important Note!

Indicates a potential malfunction which, if not avoided, however, will not result in damage to property.



Information

Additional Information:

Refers to additional information which is not an integral part of this documentation (e.g., the Internet).

1.4 Number Notation

Table 2: Number Notation

| Number code | Example | Note |
|-------------|----------------------|--|
| Decimal | 100 | Normal notation |
| Hexadecimal | 0x64 | C notation |
| Binary | '100' '0110.0100' | In quotation marks, nibble separated with dots (.) |

1.5 Font Conventions

Table 3: Font Conventions

| Font type | Indicates |
|-----------------|--|
| <i>italic</i> | Names of paths and data files are marked in italic-type. e.g.: <i>C:\Programme\WAGO-I/O-CHECK</i> |
| Menu | Menu items are marked in bold letters. e.g.: Save |
| > | A greater-than sign between two names means the selection of a menu item from a menu. e.g.: File > New |
| Input | Designation of input or optional fields are marked in bold letters, e.g.: Start of measurement range |
| “Value” | Input or selective values are marked in inverted commas. e.g.: Enter the value “4 mA” under Start of measurement range . |
| [Button] | Pushbuttons in dialog boxes are marked with bold letters in square brackets. e.g.: [Input] |
| [Key] | Keys are marked with bold letters in square brackets. e.g.: [F5] |

2 Important Notes

This section includes an overall summary of the most important safety requirements and notes that are mentioned in each individual section. To protect your health and prevent damage to devices as well, it is imperative to read and carefully follow the safety guidelines.

2.1 Legal Bases

2.1.1 Subject to Changes

WAGO Kontakttechnik GmbH & Co. KG reserves the right to provide for any alterations or modifications that serve to increase the efficiency of technical progress. WAGO Kontakttechnik GmbH & Co. KG owns all rights arising from the granting of patents or from the legal protection of utility patents. Third-party products are always mentioned without any reference to patent rights. Thus, the existence of such rights cannot be excluded.

2.1.2 Personnel Qualifications

All sequences implemented on WAGO-I/O-SYSTEM 750 devices may only be carried out by electrical specialists with sufficient knowledge in automation. The specialists must be familiar with the current norms and guidelines for the devices and automated environments.

All changes to the coupler or controller should always be carried out by qualified personnel with sufficient skills in PLC programming.

2.1.3 Use of the WAGO-I/O-SYSTEM 750 in Compliance with Underlying Provisions

Fieldbus couplers, fieldbus controllers and I/O modules found in the modular WAGO-I/O-SYSTEM 750 receive digital and analog signals from sensors and transmit them to actuators or higher-level control systems. Using programmable controllers, the signals can also be (pre-) processed.

The devices have been developed for use in an environment that meets the IP20 protection class criteria. Protection against finger injury and solid impurities up to 12.5 mm diameter is assured; protection against water damage is not ensured. Unless otherwise specified, operation of the devices in wet and dusty environments is prohibited.

Operating the WAGO-I/O-SYSTEM 750 devices in home applications without further measures is only permitted if they meet the emission limits (emissions of interference) according to EN 61000-6-3. You will find the relevant information in the section “Device Description” > “Standards and Guidelines” in the manual for the used fieldbus coupler/controller.

Appropriate housing (per 94/9/EG) is required when operating the WAGO-I/O-SYSTEM 750 in hazardous environments. Please note that a prototype test certificate must be obtained that confirms the correct installation of the system in a housing or switch cabinet.

2.1.4 Technical Condition of Specified Devices

The devices to be supplied ex works are equipped with hardware and software configurations, which meet the individual application requirements. WAGO Kontakttechnik GmbH & Co. KG will be exempted from any liability in case of changes in hardware or software as well as to non-compliant usage of devices.

Please send your request for modified and new hardware or software configurations directly to WAGO Kontakttechnik GmbH & Co. KG.

2.2 Safety Advice (Precautions)

For installing and operating purposes of the relevant device to your system the following safety precautions shall be observed:



DANGER

Do not work on devices while energized!

All power sources to the device shall be switched off prior to performing any installation, repair or maintenance work.

DANGER

Install the device only in appropriate housings, cabinets or in electrical operation rooms!

The WAGO-I/O-SYSTEM 750 and its components are an open system. As such, install the system and its components exclusively in appropriate housings, cabinets or in electrical operation rooms. Allow access to such equipment and fixtures to authorized, qualified staff only by means of specific keys or tools.

NOTICE

Do not use in telecommunication circuits!

Only use devices equipped with ETHERNET or RJ-45 connectors in LANs. Never connect these devices with telecommunication networks.

NOTICE

Replace defective or damaged devices!

Replace defective or damaged device/module (e.g., in the event of deformed contacts), since the long-term functionality of device/module involved can no longer be ensured.

NOTICE

Protect the components against materials having seeping and insulating properties!

The components are not resistant to materials having seeping and insulating properties such as: aerosols, silicones and triglycerides (found in some hand creams). If you cannot exclude that such materials will appear in the component environment, then install the components in an enclosure being resistant to the above-mentioned materials. Clean tools and materials are imperative for handling devices/modules.

NOTICE**Clean only with permitted materials!**

Clean soiled contacts using oil-free compressed air or with ethyl alcohol and leather cloths.

NOTICE**Do not use any contact spray!**

Do not use any contact spray. The spray may impair contact area functionality in connection with contamination.

NOTICE**Do not reverse the polarity of connection lines!**

Avoid reverse polarity of data and power supply lines, as this may damage the devices involved.

NOTICE**Avoid electrostatic discharge!**

The devices are equipped with electronic components that may be destroyed by electrostatic discharge when touched. Please observe the safety precautions against electrostatic discharge per DIN EN 61340-5-1/-3. When handling the devices, please ensure that environmental factors (personnel, work space and packaging) are properly grounded.

2.3 Special Use Conditions for ETHERNET Devices

If not otherwise specified, ETHERNET devices are intended for use on local networks. Please note the following when using ETHERNET devices in your system:

- Do not connect control components and control networks to an open network such as the Internet or an office network. WAGO recommends putting control components and control networks behind a firewall.
- Limit physical and electronic access to all automation components to authorized personnel only.
- Change the default passwords before first use! This will reduce the risk of unauthorized access to your system.
- Regularly change the passwords used! This will reduce the risk of unauthorized access to your system.
- If remote access to control components and control networks is required, use a Virtual Private Network (VPN).
- Regularly perform threat analyses. You can check whether the measures taken meet your security requirements.
- Use “defense-in-depth” mechanisms in your system's security configuration to restrict the access to and control of individual products and networks.

3 Device Description

The controller 750-8202(PFC200 CS 2ETH RS) is an automation device that can perform control tasks of a PLC. It is suitable for mounting on a DIN rail and stands out on account of its various interfaces.

This controller can be used for applications in mechanical and systems engineering, in the processing industry and in building technology.

You can connect all available I/O modules of the WAGO-I/O-SYSTEM 750 (750 and 753 Series) to the controller, enabling it to internally process analog and digital signals from the automation environment, or to supply these signals to other devices via one of the available interfaces.

Automation tasks can be executed in all IEC 61131-3-compatible languages with the programming system CODESYS 2.3 (WAGO-I/O-PRO).

The implementation of the CODESYS task processing is optimized with real-time extensions in order to provide maximal performance for automation tasks. For visualization, Web visualization is also available in addition to the development environment.

The controller provides a physical 256 Mbyte program memory (flash), a 256 Mbyte data memory (RAM) and a 128 kbyte remanent memory (retain, NVRAM). The memory capacities may not be able to be utilized fully on account of internal administration.

The file system on the internal memory provides 64 Mbyte for applications. Files may also be stored on a removable memory card, or on an internal RAM disk.

The controller provides a 16 Mbyte program memory, a 64 Mbyte data memory and a 128 kbyte remanent memory (retain and flag variables) in an integrated NVRAM for IEC-61131-3 programming on CODESYS applications.

Two ETHERNET interfaces and an integrated, configurable switch enable line topology wiring for:

- In line topology with a common MAC address and IP address for both interfaces.
- Two separate networks with a common MAC address and an IP address for each interface.

Both of these interfaces support:

- 10Base-T / 100Base-TX
- Full/Half duplex
- Autonegotiation
- Auto-MDI(X)

The following fieldbus circuits are implemented for exchange of process data:

- MODBUS TCP
- MODBUS UDP
- MODBUS RTU (via RS-232 or RS-485)

In the controller, all input signals from the sensors are combined. After connecting the controller, all of the I/O modules on the bus node are detected and a local process image is created from these. Analog and specialty module data is sent via words and/or bytes; digital data is sent bit by bit.

Note



No direct access from fieldbus to the process image for I/O modules!

Any data that is required from the I/O module process image must be explicitly mapped in the CODESYS program to the data in the fieldbus process image and vice versa! Direct access is not possible!

Fieldbus configuration can be performed using the CODESYS 2.3 controller configuration.

A Web-based management system (WBM) is also available as a configuration aid. This system includes various dynamic HTML pages from which, among other things, information about configuration and the status of the controller can be called up. The WBM is already stored in the device and is presented and operated using an Internet browser. You can also save your own HTML pages in the implemented file system, or call up programs directly.

In the controller's initial state, the installed firmware is based on Linux[®], with special real-time extensions of the RT-Preempt patch. In addition, the following application programs are also installed on the controller, along with a number of different auxiliary programs:

- a SNMP server/client
- a Telnet server
- a FTP, FTPS server
- a SSH server/client
- a Web server
- a NTP client
- a BootP and DHCP daemon
- a CODESYS Runtime Environment

Based on IEC-61131-3 programming, data processing takes place on site in the controller. The logical process results can be output directly to the actuators or transmitted via a connected fieldbus to the higher level controller.

Note



Memory card is not included in the scope of delivery!

Note, the controller is delivered without memory card.

To use a memory card, you must order one separately. The controller can also be operated without memory card expansion, the use of a memory card is optional.

Note



Only use recommended memory cards!

Use only the SD memory card available from WAGO (item No. 758-879/000-001) as it is suitable for industrial applications subjected to environmental extremes and was developed for use in the controller.

Compatibility with other commercially available storage media cannot be guaranteed.

3.1 View

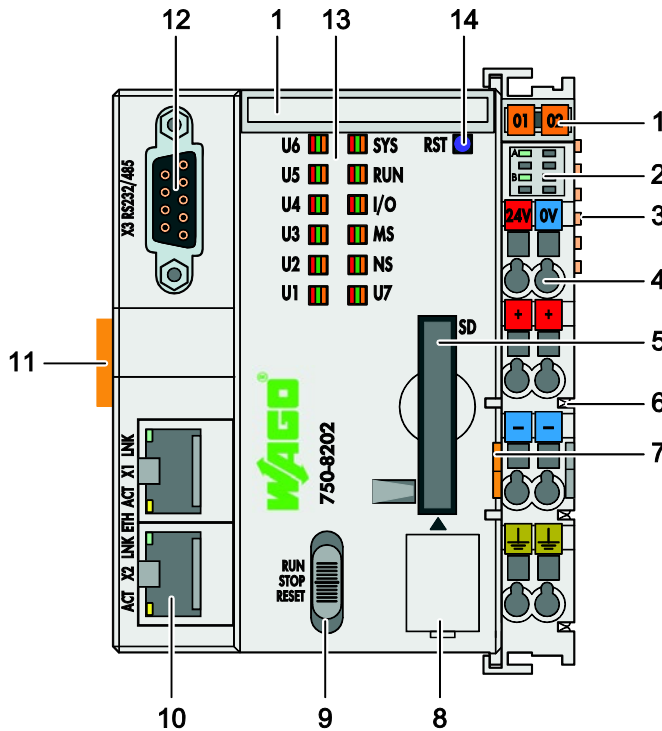

Figure 1: View of device

Table 4: Legend for figure “Device view”

| Item | Description | See section |
|------|---|---|
| 1 | Marking Options (Mini-WSB) | --- |
| 2 | LED Indicators – Power Supply | “Indicating elements” > “Indicating element power supply” |
| 3 | Data contacts | “Connections” > “Data contacts/Internal data bus” |
| 4 | CAGE CLAMP® Connections for Power Supply | “Connections” > “CAGE CLAMP® connections” |
| 5 | Slot for memory card | “Memory card slot” |
| 6 | Power contacts for power supply of down-circuit I/O modules | “Connections” > “Power contacts/ Field-side supply” |
| 7 | Releasing strap | “Mounting” > “Inserting and Removing Device” |
| 8 | Service Interface (behind the flap) | “Connections” > “Service interface” |
| 9 | Mode selector switch | “Operating elements” > “Mode selector switch” |
| 10 | ETHERNET Connections | “Connections” > “Network connections ETHERNET – X1, X2” |

| | | |
|----|-------------------------|--|
| 11 | Safe Locking Feature | “Mounting” > “Inserting and Removing Device” |
| 12 | Serial interface | “Connections” > “Communication port RS-232/RS-485 – X3” |
| 13 | LED Indicators – System | “Indicating elements” > “Indicating elements Fieldbus/System” |
| 14 | Reset button (in hole) | “Operating elements” > “Reset button” |

3.2 Connectors

3.2.1 Data Contacts/Internal Bus

NOTICE

Do not place the I/O modules on the gold spring contacts!

Do not place the I/O modules on the gold spring contacts in order to avoid soiling or scratching!

NOTICE



Ensure that the environment is well grounded!

The devices are equipped with electronic components that may be destroyed by electrostatic discharge. When handling the devices, ensure that the environment (persons, workplace and packing) is well grounded. Avoid touching conductive components, e.g. data contacts.

Communication between the controller and the I/O modules and system power supply for the I/O modules is provided via the internal data bus, which consists of 6 data contacts designed as self-cleaning gold spring contacts.

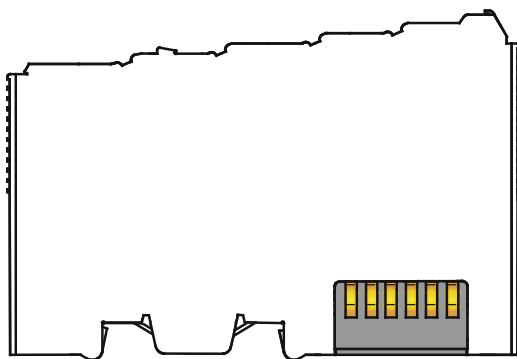

Figure 2: Data contacts

3.2.2 Power Jumper Contacts/Field Supply

⚠ CAUTION

Risk of injury due to sharp-edged blade contacts!

The blade contacts are sharp-edged. Handle the I/O module carefully to prevent injury.

The controller 750-8202 is equipped with 3 self-cleaning power contacts for transferring of the field-side power supply to down-circuit I/O modules. These contacts are designed as spring contacts.

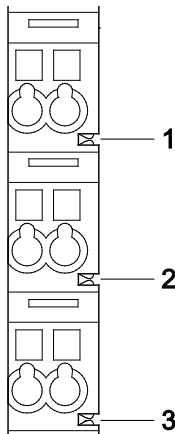

Figure 3: Power Jumper Contacts

Table 5: Legend for Figure “Power Jumper Contacts”

| Contact | Type | Function |
|---------|----------------|--|
| 1 | Spring contact | Potential transmission (U_V) for field supply |
| 2 | Spring contact | Potential transmission (0 V) for field supply |
| 3 | Spring contact | Potential transmission (ground) for field supply |

NOTICE

Do not exceed maximum current via power jumper contacts!

The maximum current to flow through the power jumper contacts is 10 A. Greater currents can damage the contacts.

When configuring your system, ensure that this current is not exceeded. If exceeded, insert an additional supply module.

3.2.3 CAGE CLAMP® Connectors

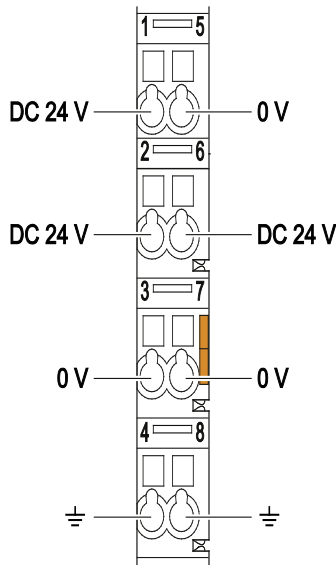

Figure 4: CAGE CLAMP® connections

Table 6: Legend for figure “CAGE CLAMP® connections”

| Contact | Description | Description |
|---------|-------------|---|
| 1 | 24 V | System power supply voltage +24 V |
| 2 | + | Field-side power supply voltage U_V |
| 3 | - | Field-side power supply voltage 0 V |
| 4 | Ground | Field-side power supply voltage, ground |
| 5 | 0 V | System power supply voltage 0 V |
| 6 | + | Field-side power supply voltage U_V |
| 7 | - | Field-side power supply voltage 0 V |
| 8 | Ground | Field-side power supply voltage, ground |

Note



Observe supplementary power supply regulations for use in shipbuilding!

Observe supplementary power supply regulations for shipbuilding and the supply voltage in Section “Connect Devices” > ... > “Supplementary Power Supply Regulations”!

3.2.4 Service Interface

The service interface is located behind the flap.

The Service interface is used for communication with WAGO-I/O-CHECK and WAGO-I/O-PRO and for firmware download.

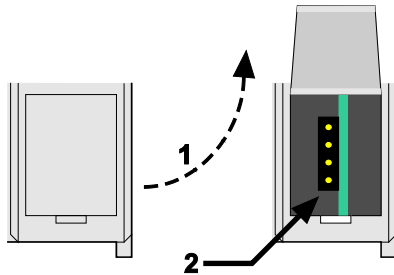

Figure 5: Service interface, (closed and open flap)

Table 7: Service interface

| Number | Description |
|--------|-------------------|
| 1 | Open flap |
| 2 | Service interface |

NOTICE

Device must be de-energized!

To prevent damage to the device, unplug and plug in the communication cable only when the device is de-energized!

The connection to the 4-pin header under the cover flap can be realized via the communication cables with the item numbers 750-920 and 750-923 or via the WAGO radio adapter with the item number 750-921.

3.2.5 Network Connections – X1, X2

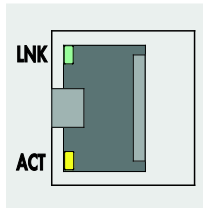

Figure 6: Network connections – X1, X2

Table 8: Legend for Figure "Network Connections – X1, X2"

| Contact | Signal | Description |
|---------|--------|-----------------|
| 1 | TD + | Transmit Data + |
| 2 | TD - | Transmit Data - |
| 3 | RD + | Receive Data + |
| 4 | NC | Not assigned |
| 5 | NC | Not assigned |
| 6 | RD - | Receive Data - |
| 7 | NC | Not assigned |
| 8 | NC | Not assigned |

3.2.6 RS-232/RS-485 – X3 Communication Connection

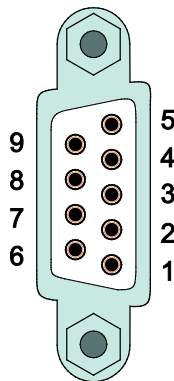

Figure 7: RS-232/RS-485 – X3 communication connection

Table 9: Key for the “RS-232/RS-485 – X3 communication connection” figure

| Contact | RS-232 | | RS-485 | |
|-----------|--------|-----------------|-----------|-------------------------|
| | Signal | Description | Signal | Description |
| 1 | NC | Not assigned | NC | Not assigned |
| 2 | RxD | Receive Data | NC | Not assigned |
| 3 | TxD | Transmit Data | RxD/TxD-P | Receive/transmit data + |
| 4 | NC | Not assigned | NC | Not assigned |
| 5 | FB_GND | Ground | FB_GND | Ground |
| 6 | NC | Not assigned | FB_5V | Power Supply |
| 7 | RTS | Request to send | NC | Not assigned |
| 8 | CTS | Clear to send | RxD/TxD-N | Receive/transmit data - |
| 9 | NC | Not assigned | NC | Not assigned |
| Enclosure | Shield | Shielding | Shield | Shielding |

NOTICE

Incorrect parameterization can damage the communication partners!

The voltage levels are -12 V and +12 V for RS-232, and -5 V and +5 V for RS-485.

If the controller interfaces differ from those of the communication partners (RS-232 \leftrightarrow RS-485 or RS-485 \leftrightarrow RS-232), this may damage the interface of the communication partner.

Therefore, always ensure that the controller interface matches those of its communication partners when configuring these items!

DC/DC converters and optocouplers in the fieldbus interface electrically isolate the fieldbus system and the electronics.

3.2.6.1 Operating as an RS-232 Interface

Depending on the device type DTE (e.g., PC) or DCE (e.g., PFC, modem), the RS-232 signals have different data directions.

Table 10: Function of RS-232 signals for DTE/DCE

| Contact | Signal | Data Direction | |
|---------|--------|----------------|--------|
| | | DTE | DCE |
| 2 | RxD | Input | Output |
| 3 | TxD | Output | Input |
| 5 | FB_GND | --- | --- |
| 7 | RTS | Output | Input |
| 8 | CTS | Input | Output |

For a DTE-to-DCE connection, the signals are connected directly (1:1).

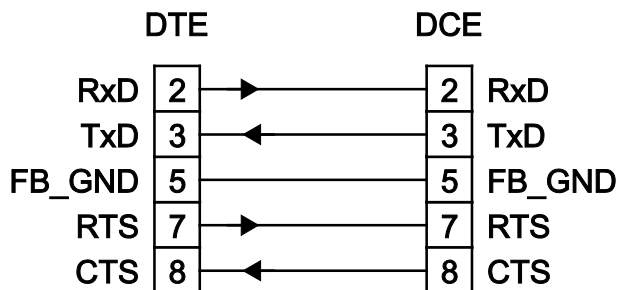

Figure 8: Termination with DTE-DCE connection (1:1)

For a DTE-to-DTE connection, the signal connections are crossed.

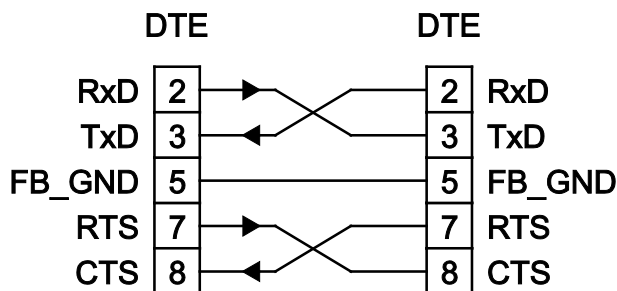

Figure 9: Termination with DTE-DTE connection (cross-over)

3.2.6.2 Operating as an RS-485 Interface

To minimize reflection at the end of the line, the RS-485 line must be terminated at both ends by a cable termination. If required, one pull-up or pull-down resistor may be used. These resistors ensure a defined level on the bus when no subscriber is active, i.e., when all subscribers are in “Tri-state”.

Note



Attention — bus termination!

The RS-485 MODBUS bus segment must be terminated at both ends!

No more than two terminations per bus segment may be used!

Terminations may not be used in stub and branch lines!

Operation without proper termination of the RS-485 MODBUS network may result in transmission errors.

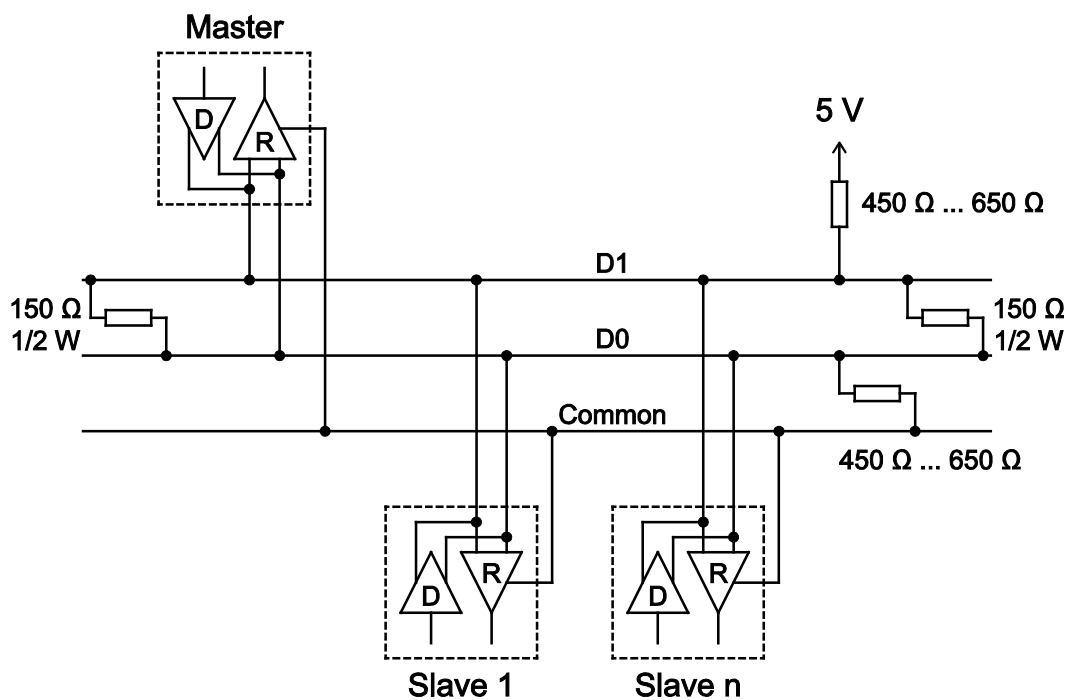

Figure 10: RS-485 bus termination

3.3 Display Elements

3.3.1 Power Supply Indicating Elements

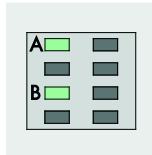

Figure 11: Power supply indicating elements

Table 11: Legend for Figure “Power Supply Indicating Elements”

| Description | Color | Description |
|-------------|-----------|---|
| A | Green/off | Status of system power supply voltage |
| B | Green/off | Status of field-side power supply voltage |

3.3.2 Fieldbus/System Indicating Elements













U6   SYS
 U5   RUN
 U4   I/O
 U3   MS
 U2   NS
 U1   U7

Figure 12: Indicating elements for fieldbus/system

Table 12: Legend for figure “Fieldbus/System Indicating Elements”

| Description | Color | Description |
|-------------|--------------------------|---|
| SYS | Red/Green/ Orange/Off | System status |
| RUN | Red/Green/ Orange/Off | PLC program status |
| I/O | Red/Green/ Orange/Off | Internal data bus status |
| CG | Without function | |
| NS | Without function | |
| U7 | Green/Red/ Orange/Off | User LED 7, programmable using the function blocks of the “WagoLibLed.lib” library. |
| U6 | Green/Red/ Orange/Off | User LED 6, programmable using the function blocks of the “WagoLibLed.lib” library. |
| U5 | Green/Red/ Orange/Off | User LED 5, programmable using the function blocks of the “WagoLibLed.lib” library. |
| U4 | Red/Green/ Orange/Off | User LED 4, programmable using the function blocks of the “WagoLibLed.lib” library. |
| U3 | Red/Green/ Orange/Off | User LED 3, programmable using the function blocks of the “WagoLibLed.lib” library. |
| U2 | Red/Green/ Orange/Off | User LED 2, programmable using the function blocks of the “WagoLibLed.lib” library. |
| U1 | Red/Green/ Orange/Off | User LED 1, programmable using the function blocks of the “WagoLibLed.lib” library. |

3.3.3 Memory Card Indicating Elements

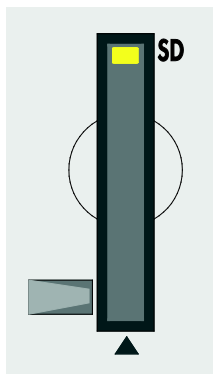

Figure 13: Indicating elements, memory card slot

Table 13: Legend for figure “Indicating Elements, memory card slot”

| Description | Color | Description |
|-------------|------------|--------------------|
| SD | Yellow/Off | Memory card status |

3.3.4 Network Indicating Elements

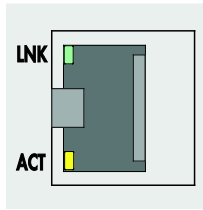

Figure 14: Indicating elements, RJ-45 jacks

Table 14: Legend for figure “Indicating elements, RJ-45 jacks”

| Description | Color | Description |
|-------------|------------|----------------------------|
| LNK | Green/Off | ETHERNET connection status |
| ACT | Yellow/Off | ETHERNET data exchange |

3.4 Operating Elements

3.4.1 Operating Mode Switch

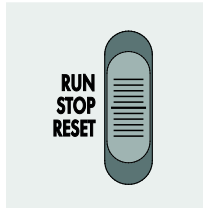

Figure 15: Mode selector switch

Table 15: Mode selector switch

| Item | Activation | Function |
|-------|---------------|--|
| RUN | Latching | Normal mode CODESYS 2 application runs. |
| STOP | Latching | Stop CODESYS 2 application stopped. |
| RESET | Spring-return | Reset warm start or Reset cold start (based on the duration of activation, see Section “Starting” > “Initiating Reset Functions”) |

Other functions can also be initiated using the reset button.

3.4.2 Reset Button

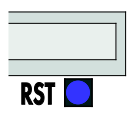

Figure 16: Reset button

The Reset button can be actuated using a suitable object (e.g., pen) through a hole in the enclosure.

Depending on the position of the mode selector switch, the Reset button can be used to initiate different functions: Software reset, factory reset or fixed IP address.

Information about these functions are given in the Section “Starting” > “Initiating Reset Functions”.

3.5 Slot for Memory Card

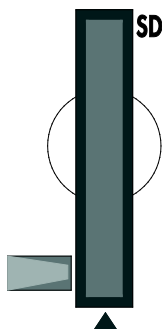

Figure 17: Memory card slot

The memory card is locked in the enclosure by a push/push mechanism. Inserting and removing the card is described in the Section “Service” > “Inserting and Removing the Memory Card”.

The memory card is protected by a cover flap, which can also be sealed.

Note



Memory card is not included in the scope of delivery!

Note, the controller is delivered without memory card.

To use a memory card, you must order one separately. The controller can also be operated without memory card expansion, the use of a memory card is optional.

Note



Only use recommended memory cards!

Use only the SD memory card available from WAGO (item No. 758-879/000-001) as it is suitable for industrial applications subjected to environmental extremes and was developed for use in the controller.

Compatibility with other commercially available storage media cannot be guaranteed.

3.6 Schematic Diagram

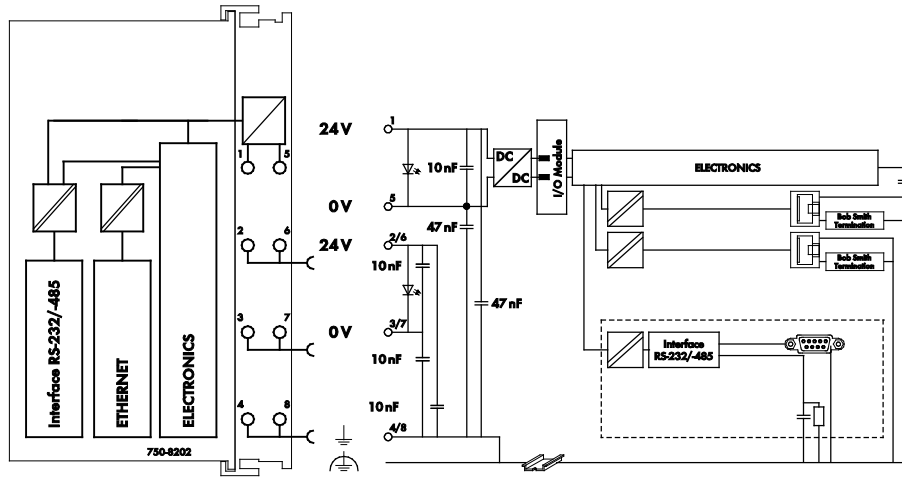

Figure 18: Schematic diagram

3.7 Technical Data

3.7.1 Device Data

Table 16: Technical data, device data

| | |
|---|--------|
| Width | 75 mm |
| Height (from upper edge of DIN 35 rail) | 65 mm |
| Length | 100 mm |
| Weight | 190 g |

3.7.2 System Data

Table 17: Technical Data – System Data

| | |
|-------------------------------------|--|
| CPU | Cortex A8, 600 MHz |
| Operating System | Real-time Linux [®] 3.6 (with RT Preemption Patch) |
| Main memory (RAM) | 256 MB |
| Internal memory (flash) | 256 MB |
| Non-volatile memory (Retain, NVRAM) | 128 KB |
| Memory card slot | Push-push mechanism, sealing cover lid |
| Type of memory card | SD and SDHC up to 32 Gbytes (All guaranteed properties are valid only in connection with the WAGO 758-879/000-001 memory card.) |

3.7.3 Power supply

Table 18: Technical Data – Power Supply

| | |
|------------------------------------|--------------------------|
| Power supply | 24 VDC (-25 % ... +30 %) |
| Max. input current (24 V) | 550 mA |
| Total current for I/O modules (5V) | 1700 mA |
| Isolation | 500 V system/supply |

3.7.4 Clock

Table 19: Technical data – Clock

| | |
|------------------------------|---------|
| Drift - system clock (25 °C) | 20 ppm |
| Drift - RTC (25 °C) | 3 ppm |
| Buffer time RTC | 30 days |

3.7.5 Programming

Table 20: Technical Data – Programming

| | |
|--|---------------------|
| Programming | WAGO-I/O-PRO V2.3 |
| IEC 61131-3 | IL, LD, FBD, ST, FC |
| Program memory (Flash) | 16 MB |
| Data memory (RAM) | 64 MB |
| Non-volatile memory (Retain + Flag, NVRAM) | 128 KB |

3.7.6 Internal data bus

Table 21: Technical Data – Internal Data Bus

| | |
|---------------------------------------|------------|
| Number of I/O modules (per node) | 64 |
| with bus extension | 250 |
| Input and output process image (max.) | 1000 words |

3.7.7 ETHERNET

Table 22: Technical Data – ETHERNET

| | |
|---|---|
| ETHERNET | 2 x RJ-45 (switched or separated mode) |
| Transmission medium | Twisted Pair S-UTP, 100 Ω, Cat 5, 100 m maximum cable length |
| Baud rate | 10/100 Mbit/s; 10Base-T/100Base-TX |
| Protocols | DHCP, DNS, SNTP, FTP, FTPS, SNMP, HTTP, HTTPS, SSH, MODBUS (TCP, UDP) |
| MODBUS input and output process image, max. | 1000 words, also with MODBUS access to the flag area (see Section "MODBUS" > ... > "Flag Area") |

Note



No direct access from fieldbus to the process image for I/O modules!

Any data that is required from the I/O module process image must be explicitly mapped in the CODESYS program to the data in the fieldbus process image and vice versa! Direct access is not possible!

3.7.8 Serial interface

Table 23: Technical Data – Serial Interface

| | |
|-----------|--|
| Interface | 1 x serial interface per TIA/EIA 232 and TIA/EIA 485 (switchable), 9-pole D-sub female connector |
| Protocols | MODBUS RTU |

3.7.9 Connection Type

Table 24: Technical Data – Field Wiring

| | |
|------------------|--|
| Wire connection | CAGE CLAMP® |
| Cross section | 0.08 mm ² ... 2.5 mm ² , AWG 28 ... 14 |
| Stripped lengths | 8 mm ... 9 mm / 0.33 in |

Table 25: Technical Data – Power Jumper Contacts

| | |
|-----------------------------------|-------------------------------|
| Power jumper contacts | spring contact, self-cleaning |
| Voltage drop at I _{max.} | < 1 V/64 modules |

Table 26: Technical Data – Data Contacts

| | |
|---------------|--|
| Data contacts | Slide contact, hard gold plated, self-cleaning |
|---------------|--|

3.7.10 Climatic Environmental Conditions

Table 27: Technical Data – Climatic Environmental Conditions

| | |
|--|---|
| Operating temperature range | 0 °C ... 55 °C |
| Operating temperature range for components with extended temperature range (750-xxx/025-xxx) | -20 °C ... +60 °C |
| Storage temperature range | -25 °C ... +85 °C |
| Storage temperature range for components with extended temperature range (750-xxx/025-xxx) | -40 °C ... +85 °C |
| Relative humidity | Max. 5 % ... 95 % without condensation |
| Resistance to harmful substances | Acc. to IEC 60068-2-42 and IEC 60068-2-43 |
| Maximum pollutant concentration at relative humidity < 75 % | SO ₂ ≤ 25 ppm H ₂ S ≤ 10 ppm |
| Special conditions | Ensure that additional measures for components are taken, which are used in an environment involving: <ul style="list-style-type: none"> – dust, caustic vapors or gases – ionizing radiation |

3.8 Approvals

The following approvals have been granted to the controller “PFC200 CS 2ETH RS” (750-8202):

 Conformity Marking

 cUL_{US} UL508

The following ship approvals have been granted to the basic version of the controller “PFC200 CS 2ETH RS” (750-8202):

 GL (Germanischer Lloyd) Cat. A, B, C, D (EMC 1)

3.9 Standards and Guidelines

The controller “PFC200 CS 2ETH RS” (750-8202) fulfills the following EMC standards:

EMC CE-Immunity to interference acc. to EN 61000-6-2: 2005

EMC CE-Emission of interference acc. to EN 61000-6-3: 2007 + A1: 2011

4 Function Description

4.1 Network Configuration

ETHERNET interfaces X1 and X2 of the controller can be operated in Switch mode or as separate network interfaces.

Switch mode can be switched ON or OFF at run-time.

Switch mode is ON by default and during initial startup. Configuration mode is set to “DHCP”.

For interface X1, a fixed IP address can be set.
Setting a fixed IP address has no effect on the mode previously set.

4.1.1 Operation in Switch Mode

For operation in Switch mode, the TCP/IP settings such as the IP address or subnet mask apply for both X1 and X2.

When switching to Switch mode, the X1 settings are applied as a new common configuration for X1 and X2.

The device is then no longer accessible via the IP address previously set for X2. For CODESYS applications that use X2 for communication must take this into account.

4.1.2 Operation with Separate Network Interfaces

When operating with separate network interfaces, both ETHERNET interfaces can be configured and used separately.

Note that two interfaces still have the same MAC address. Therefore, they must not be operated in the same network segment.

When switching to operating with separate interfaces, interface X2 is initialized with the setting values last valid for it. The connections on the X1 interface persist.

When operating with separate interfaces and fixed IP address, the device can still be accessed via interface X2 via the regular IP address.

5 Mounting

5.1 Installation Position

Along with horizontal and vertical installation, all other installation positions are allowed.

Note



Use an end stop in the case of vertical mounting!

In the case of vertical assembly, an end stop has to be mounted as an additional safeguard against slipping.

WAGO order no. 249-116 End stop for DIN 35 rail, 6 mm wide

WAGO order no. 249-117 End stop for DIN 35 rail, 10 mm wide

5.2 Overall Configuration

The maximum total length of a fieldbus node without fieldbus coupler/controller is 780 mm including end module. The width of the end module is 12 mm. When assembled, the I/O modules have a maximum length of 768 mm.

Examples:

- 64 I/O modules with a 12 mm width can be connected to a fieldbus coupler/controller.
- 32 I/O modules with a 24 mm width can be connected to a fieldbus coupler/controller.

Exception:

The number of connected I/O modules also depends on the type of fieldbus coupler/controller is used. For example, the maximum number of stackable I/O modules on one PROFIBUS DP/V1 fieldbus coupler/controller is 63 with no passive I/O modules and end module.

NOTICE

Observe maximum total length of a fieldbus node!

The maximum total length of a fieldbus node without fieldbus coupler/controller and without using a 750-628 I/O Module (coupler module for internal data bus extension) may not exceed 780 mm.

Also note the limitations of individual fieldbus couplers/controllers.



Note

Increase the total length using a coupler module for internal data bus extension!

You can increase the total length of a fieldbus node by using a 750-628 I/O Module (coupler module for internal data bus extension). For such a configuration, attach a 750-627 I/O Module (end module for internal data bus extension) after the last I/O module of a module assembly. Use an RJ-45 patch cable to connect the I/O module to the coupler module for internal data bus extension of another module block.

This allows you to segment a fieldbus node into a maximum of 11 blocks with maximum of 10 I/O modules for internal data bus extension.

The maximum cable length between two blocks is five meters.

More information is available in the manuals for the 750-627 and 750-628 I/O Modules.

5.3 Mounting onto Carrier Rail

5.3.1 Carrier Rail Properties

All system components can be snapped directly onto a carrier rail in accordance with the European standard EN 50022 (DIN 35).

NOTICE

Do not use any third-party carrier rails without approval by WAGO!

WAGO Kontakttechnik GmbH & Co. KG supplies standardized carrier rails that are optimal for use with the I/O system. If other carrier rails are used, then a technical inspection and approval of the rail by WAGO Kontakttechnik GmbH & Co. KG should take place.

Carrier rails have different mechanical and electrical properties. For the optimal system setup on a carrier rail, certain guidelines must be observed:

- The material must be non-corrosive.
- Most components have a contact to the carrier rail to ground electro-magnetic disturbances. In order to avoid corrosion, this tin-plated carrier rail contact must not form a galvanic cell with the material of the carrier rail which generates a differential voltage above 0.5 V (saline solution of 0.3 % at 20°C).
- The carrier rail must optimally support the EMC measures integrated into the system and the shielding of the I/O module connections.
- A sufficiently stable carrier rail should be selected and, if necessary, several mounting points (every 20 cm) should be used in order to prevent bending and twisting (torsion).
- The geometry of the carrier rail must not be altered in order to secure the safe hold of the components. In particular, when shortening or mounting the carrier rail, it must not be crushed or bent.
- The base of the I/O components extends into the profile of the carrier rail. For carrier rails with a height of 7.5 mm, mounting points are to be riveted under the node in the carrier rail (slotted head captive screws or blind rivets).
- The medal springs on the bottom of the housing must have low-impedance contact with the DIN rail (wide contact surface is possible).

5.3.2 WAGO DIN Rail

WAGO carrier rails meet the electrical and mechanical requirements shown in the table below.

Table 28: WAGO DIN Rail

| Order number | Description |
|---------------|--|
| 210-113 /-112 | 35 x 7.5; 1 mm; steel yellow chromated; slotted/unslotted |
| 210-114 /-197 | 35 x 15; 1.5 mm; steel yellow chromated; slotted/unslotted |
| 210-118 | 35 x 15; 2.3 mm; steel yellow chromated; unslotted |
| 210-198 | 35 x 15; 2.3 mm; copper; unslotted |
| 210-196 | 35 x 7.5; 1 mm; aluminum; unslotted |

5.4 Spacing

The spacing between adjacent components, cable conduits, casing and frame sides must be maintained for the complete fieldbus node.

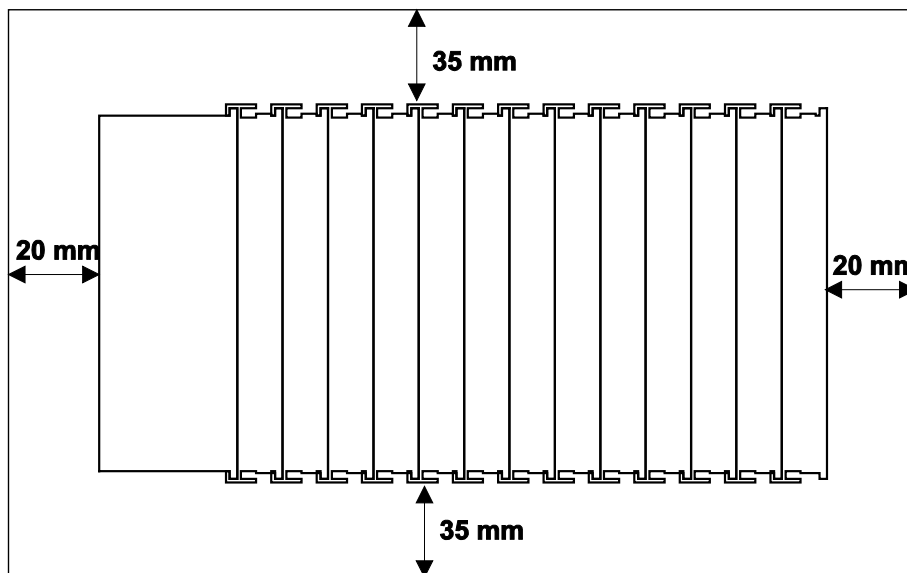

Figure 19: Spacing

The spacing creates room for heat transfer, installation or wiring. The spacing to cable conduits also prevents conducted electromagnetic interferences from influencing the operation.

5.5 Mounting Sequence

Fieldbus couplers/controllers and I/O modules of the WAGO-I/O-SYSTEM 750 are snapped directly on a carrier rail in accordance with the European standard EN 50022 (DIN 35).

The reliable positioning and connection is made using a tongue and groove system. Due to the automatic locking, the individual devices are securely seated on the rail after installation.

Starting with the fieldbus coupler/controller, the I/O modules are mounted adjacent to each other according to the project design. Errors in the design of the node in terms of the potential groups (connection via the power contacts) are recognized, as the I/O modules with power contacts (blade contacts) cannot be linked to I/O modules with fewer power contacts.

CAUTION

Risk of injury due to sharp-edged blade contacts!

The blade contacts are sharp-edged. Handle the I/O module carefully to prevent injury.

NOTICE

Insert I/O modules only from the proper direction!

All I/O modules feature grooves for power jumper contacts on the right side. For some I/O modules, the grooves are closed on the top. Therefore, I/O modules featuring a power jumper contact on the left side cannot be snapped from the top. This mechanical coding helps to avoid configuration errors, which may destroy the I/O modules. Therefore, insert I/O modules only from the right and from the top.

Note



Don't forget the bus end module!

Always plug a bus end module 750-600 onto the end of the fieldbus node! You must always use a bus end module at all fieldbus nodes with WAGO-I/O-SYSTEM 750 fieldbus couplers/controllers to guarantee proper data transfer.

5.6 Inserting Devices

NOTICE

Perform work on devices only if they are de-energized!

Working on energized devices can damage them. Therefore, turn off the power supply before working on the devices.

5.6.1 Inserting the Fieldbus Coupler/Controller

1. When replacing the fieldbus coupler/controller for an already available fieldbus coupler/controller, position the new fieldbus coupler/controller so that the tongue and groove joints to the subsequent I/O module are engaged.
2. Snap the fieldbus coupler/controller onto the carrier rail.
3. Use a screwdriver blade to turn the locking disc until the nose of the locking disc engages behind the carrier rail (see the following figure). This prevents the fieldbus coupler/controller from canting on the carrier rail.

With the fieldbus coupler/controller snapped in place, the electrical connections for the data contacts and power contacts (if any) to the possible subsequent I/O module are established.

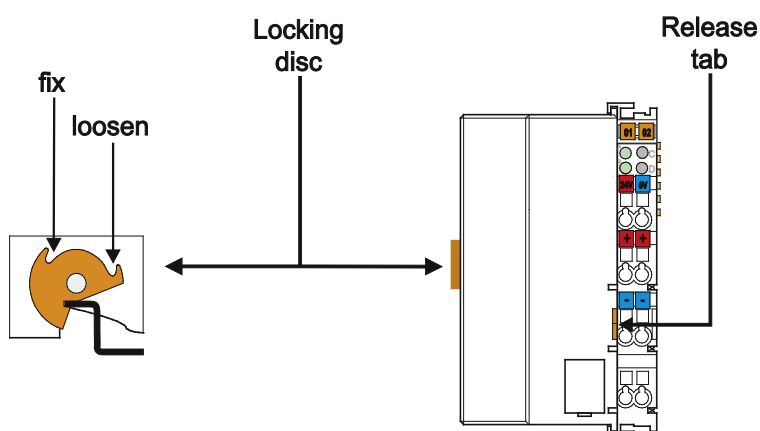

Figure 20: Release Tab of Controller

5.6.2 Inserting the I/O Module

1. Position the I/O module so that the tongue and groove joints to the fieldbus coupler/controller or to the previous or possibly subsequent I/O module are engaged.

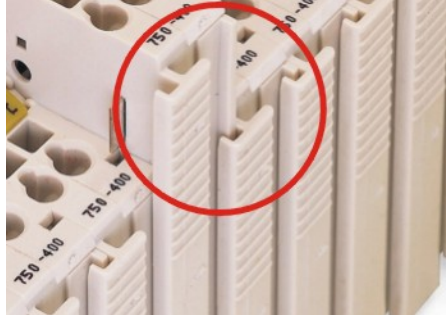

Figure 21: Insert I/O Module (Example)

2. Press the I/O module into the assembly until the I/O module snaps into the carrier rail.

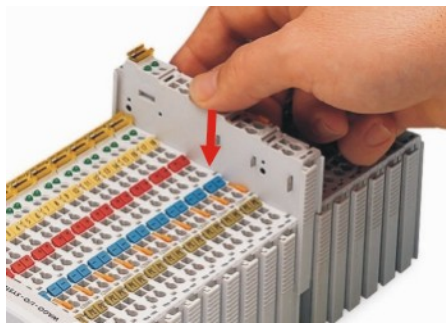

Figure 22: Snap the I/O Module into Place (Example)

With the I/O module snapped in place, the electrical connections for the data contacts and power jumper contacts (if any) to the fieldbus coupler/controller or to the previous or possibly subsequent I/O module are established.

6 Connect Devices

6.1 Connecting a Conductor to the CAGE CLAMP®

The WAGO CAGE CLAMP® connection is appropriate for solid, stranded and finely stranded conductors.

NOTICE

Select conductor cross sections as required for current load!

The current consumed for field-side supply may not exceed 10 A. The wire cross sections must be sufficient for the maximum current load for all of the I/O modules to be supplied with power.

Note



Only connect one conductor to each CAGE CLAMP® connection!

Only one conductor may be connected to each CAGE CLAMP® connection. Do not connect more than one conductor at one single connection!

If more than one conductor must be routed to one connection, these must be connected in an up-circuit wiring assembly, for example using WAGO feed-through terminals.

Exception:

If it is unavoidable to jointly connect 2 conductors, then you must use a ferrule to join the wires together. The following ferrules can be used:

| | |
|---------------------------------------|--|
| Length | 8 mm |
| Nominal cross section _{max.} | 1 mm ² for 2 conductors with 0.5 mm ² each |
| WAGO Product | 216-103 or products with comparable properties. |

1. To open the CAGE CLAMP® insert the actuating tool into the opening above the connection.
2. Insert the conductor into the corresponding connection opening.
3. To close the CAGE CLAMP® simply remove the tool - the conductor is then clamped firmly in place.

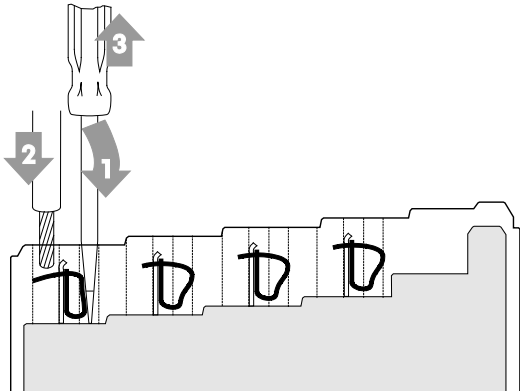

Figure 23: Connecting a conductor to a CAGE CLAMP®

6.2 Power Supply Concept

6.2.1 Supplementary Power Supply Regulations

The WAGO-I/O-SYSTEM 750 can also be used in shipbuilding or offshore and onshore areas of work (e. g. working platforms, loading plants). This is demonstrated by complying with the standards of influential classification companies such as Germanischer Lloyd and Lloyds Register.

Filter modules for 24 V supply are required for the certified operation of the system.

Table 29: Filter Modules for 24 V Supply

| Order No. | Name | Description |
|-----------|---------------|--|
| 750-626 | Supply Filter | Filter module for system supply and field supply (24 V, 0 V), i. e. for fieldbus coupler/controller and bus power supply (750-613) |
| 750-624 | Supply Filter | Filter module for the 24 V field supply (750-602, 750-601, 750-610) |

Therefore, the following power supply concept must be absolutely complied with.

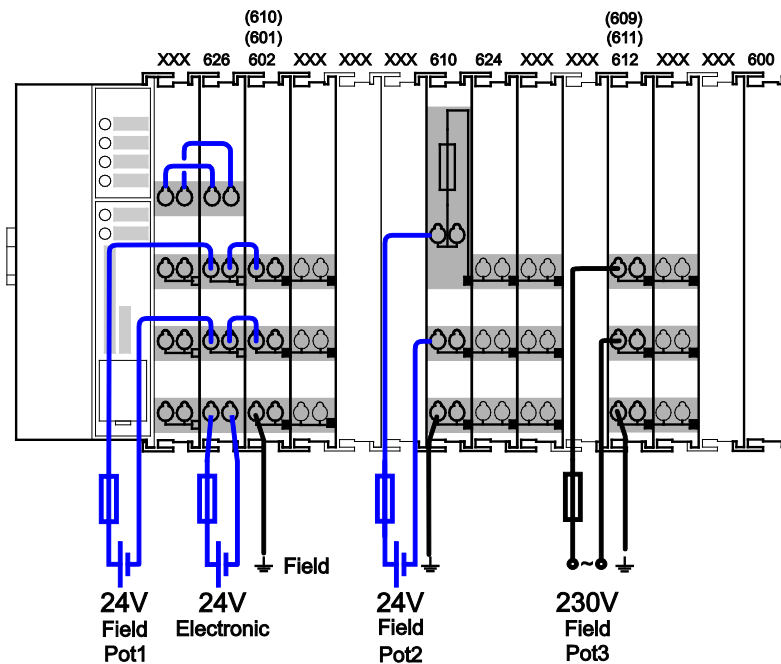

Figure 24: Power Supply Concept

Note



Use a supply module for equipotential bonding!

Use an additional 750-601/ 602/ 610 Supply Module behind the 750-626 Filter Module if you want to use the lower power jumper contact for equipotential bonding, e.g., between shielded connections and require an additional tap for this potential.

7 Commissioning

7.1 Switching On the Controller

Before switching on the controller ensure that you

- have properly installed the controller (see section “Installation”),
- have connected all required data cables (see section “Connections”) to the corresponding interfaces and have secured the connectors by their attached locking screws,
- have connected the electronics and field-side power supply (see section “Connections”),
- have mounted the end module (750-600) (see Section “Installation”),
- have performed appropriate potential equalization at your machine/system (see System Description for 750-xxx) and
- have performed shielding properly (see System Description for 750-xxx).

To switch on both the controller and the connected I/O modules, switch on your power supply unit.

Starting of the controller is indicated by a brief green flashing of all LEDs. After a few seconds the SYS LED will signal successful boot-up of the controller. The CODESYS 2.3 runtime system is started simultaneously.

Once the entire system has been successfully started, the SYS and I/O LEDs light up green.

If there is no executable IEC-61131-3 program stored on the controller, or if the RUN/STOP switch is set to STOP, the RUN LED will light up red.

7.2 Determining the IP Address of the Host PC

To ensure that the host PC can communicate with the controller via ETHERNET, both devices must be located in the same subnet.

To determine the IP address of the host PC (with the Microsoft Windows® operating system) using the MS DOS prompt, proceed as follows:

1. Open the MS DOS prompt window.
To do this, enter the command “cmd” in the input field under **Start > Execute... > Open:** (Windows® XP) or **Start > Search programs/files** (Windows® 7) and then click **[OK]** or press **[Enter]**.
2. In the MS DOS prompt enter the command “ipconfig” and then press **[Enter]**.
3. The IP address, subnet mask and standard gateway, including the appropriate parameters, are displayed.

7.3 Setting an IP Address

In the controller's initial state the following IP addresses are active for the ETHERNET interface (Port X1 and Port X2):

Table 30: Default IP Addresses for ETHERNET Interfaces

| Ethernet interface | Default setting |
|---------------------------|---|
| X1/X2 | Dynamic assignment of IP address using “Dynamic Host Configuration Protocol” (DHCP) |

Adapt IP addressing for your specific system structure to ensure that the PC and the controller can communicate with one another using one of the available configuration tools (WBM, “WAGO Ethernet Settings”, CBM) (see section “Configuration”).

Example for incorporating the controller (192.168.2.17) into an existing network:

If the IP address of your host PC is 192.168.1.2, for example, then the controller must be on the same subnet. That is, with the net mask **255.255.255.0**, the first three digits of the controller must match those of your PC. This yields the following address range for the controller:

Table 31: Network Mask 255.255.255.0

| Host PC | Subnet address range for the controller |
|--------------------|--|
| 192.168.1.2 | 192.168.1.3 ... 192.168.1.254 |

7.3.1 Assigning an IP Address using DHCP

The PFC200 can obtain dynamic IP addresses from a server (DHCP/BootP). In contrast to fixed IP addresses, dynamically assigned addresses are not stored permanently. Therefore, a BootP or DHCP server must be available each time the controller is restarted.

If an IP address has been assigned by means of DHCP (default setting), it can be determined through the settings and the output of the specific DHCP server.

In the example figure shown here, the corresponding output of “Open DHCP” is presented.

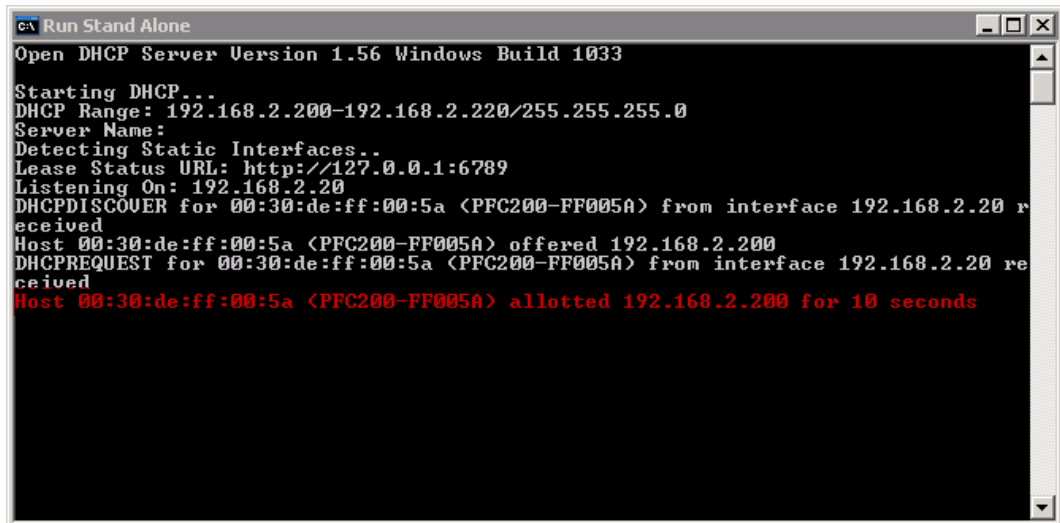

```
c:\ Run Stand Alone
Open DHCP Server Version 1.56 Windows Build 1033

Starting DHCP...
DHCP Range: 192.168.2.200-192.168.2.220/255.255.255.0
Server Name:
Detecting Static Interfaces..
Lease Status URL: http://127.0.0.1:6789
Listening On: 192.168.2.20
DHCPDISCOVER for 00:30:de:ff:00:5a <PFC200-FF005A> from interface 192.168.2.20 received
Host 00:30:de:ff:00:5a <PFC200-FF005A> offered 192.168.2.200
DHCPOFFER for 00:30:de:ff:00:5a <PFC200-FF005A> from interface 192.168.2.20 received
Host 00:30:de:ff:00:5a <PFC200-FF005A> allotted 192.168.2.200 for 10 seconds
```

Figure 25: “Open DHCP”, example figure

In conjunction with the DNS server associated with DHCP, the device can be reached using its host name.

This name consists of the prefix “PFC200-“ and the last six places of the MAC address (in the example shown here: “00:30:DE:FF:00:5A”). The MAC address of the device can be printed on the label on the side of the device.

The host name of the device in the example shown here is thus “PFC200-FF005A”.

7.3.2 Changing an IP Address using the “CBM” Configuration Tool via the Serial Interface

Using the “CBM” configuration tool accessible on the Linux® console, you can assign, among other things, a new IP address to the ETHERNET interfaces X1 and X2. More information about “CBM” is given in the Section “Configuration”.

Preparation:

Link a PC to the X3 serial interface using a terminal program.

1. Start the configuration tool by entering the command “cbm” on the command line and then press **[Enter]**.

```
=====
WAGO Console Based Management Tool
=====
Main Menu
-----
0. Quit
1. Information
2. CODESYS
3. Networking
4. Clock
5. Administration
6. Package Server
7. Mass Storage
8. Downloads
9. Ports and Services
10. SNMP
-----
Select an entry or Q to quit
=====
```

Figure 26: CBM starting screen

2. In the **Main menu** use the keyboard (arrow keys or numeric keypad) to move to and select **Networking** and then press **[Enter]**.

```
=====
WAGO Console Based Management Tool
=====
Main Menu
-----
0. Quit
1. Information
2. CODESYS
3. Networking
4. Clock
5. Administration
6. Package Server
7. Mass Storage
8. Downloads
9. Ports and Services
10. SNMP
-----
Select an entry or Q to quit
=====
```

Figure 27: CBM – Selecting “Networking”

3. In the **Networking** menu select **TCP/IP** and press **[Enter]**.

```
=====
WAGO Console Based Management Tool
=====
Networking
-----
0. Back to Main Menu
1. Host-/Domain Name
2. TCP/IP
3. Ethernet
-----
Select an entry or Q to quit
-----
█
```

Figure 28: CBM – Selecting “TCP/IP”

4. In the menu **TCP/IP** select **IP Address** and press **[Enter]**.

```
=====
WAGO Console Based Management Tool
=====
TCP/IP
-----
0. Back to Networking Menu
1. IP Address
2. Default Gateway
3. DNS Server
-----
Select an entry or Q to quit
-----
█
```

Figure 29: CBM – Selecting “IP address”

5. In the menu **TCP/IP Configuration** select **IP Address** and press **[Enter]**.

```
=====
WAGO Console Based Management Tool
=====
TCP/IP Configuration
-----
0. Back to TCP/IP Menu
1. Type of IP Address Configuration...Static IP
2. IP Address.....192.168.1.17
3. Subnet Mask.....255.255.255.0
-----
Select an entry or Q to quit
█
```

Figure 30: CBM – Selecting the IP address

6. In the menu **Change IP Address** enter the new IP address and confirm by clicking **[OK]**. If you want to return to the main menu without making changes, click **[Abort]**.

```
=====
WAGO Console Based Management Tool
=====
Change IP Address
-----
Enter new IP Address:
+-----+
|192.168.1.17 |
+-----+
< OK >   <Abort>
-----
OK: confirm value, Abort: quit without changes
-----
```

Figure 31: CBM – Entering a new IP address

7.3.3 Changing an IP Address using “WAGO Ethernet Settings”

The Microsoft Windows® application “WAGO Ethernet Settings” is a software used to identify the controller and configure network settings.

Note



Observe the software version!

To configure the controller use at least Version 5.4.2.3 dated July 20, 2013 in “WAGO Ethernet Settings”!

You can use WAGO communication cables or WAGO radio adapters or even the IP network for data communication.

1. Switch off the power supply to the controller.
2. Connect the 750-920 communication cable to the Service interface on the controller and to a serial interface of your PC.
3. Switch the power supply to the controller on again.
4. Start the “WAGO Ethernet Settings” program.

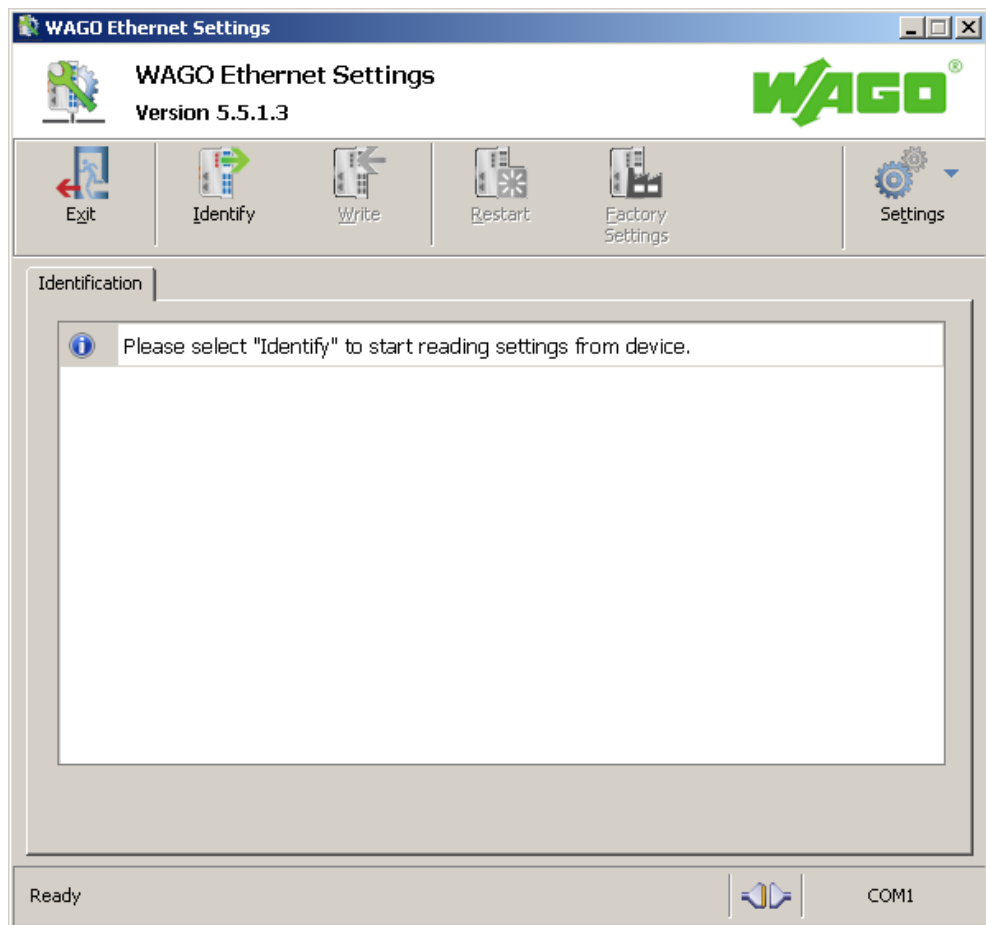

Figure 32: "WAGO Ethernet Settings" – Starting screen

5. Click **[Identify]** to read in and identify the connected PFC200.
6. Select the “Network” tab:

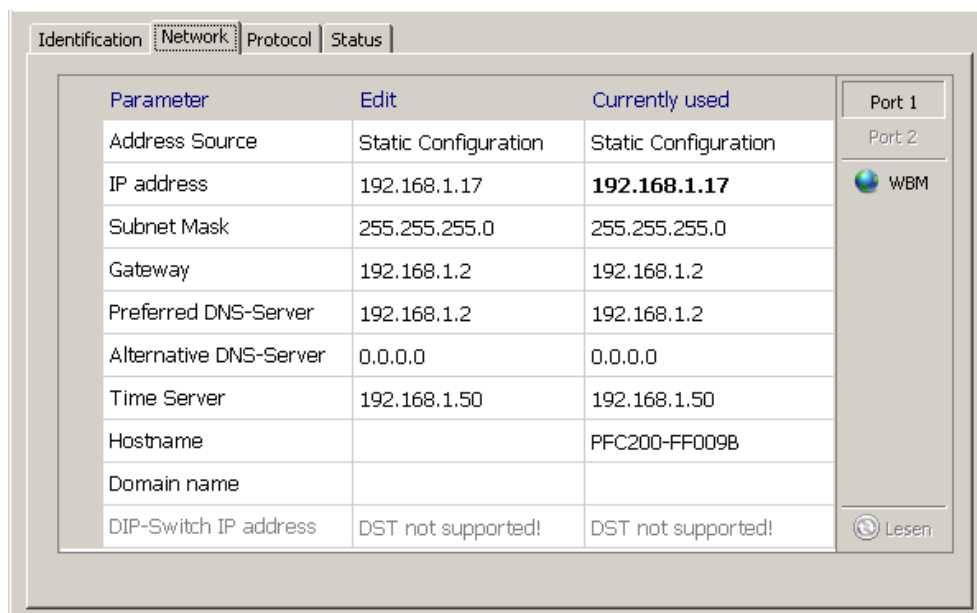

Figure 33: “WAGO Ethernet Settings” – “Network” tab

7. To assign a fixed address, select “Static configuration” on the “Source” line under “Input”. DHCP is normally activated as the default setting.
8. In the column “Input” enter the required IP address and, if applicable, the address of the subnet mask and of the gateway.
9. Click on **[Write]** to accept the address in the PFC200. (When you click the **[Write]** button “WAGO Ethernet Settings” will automatically restart your controller. This action therefore requires about 30 seconds.)
10. You can now close “WAGO Ethernet Settings”, or make other changes directly in the Web-based Management system as required. To do this, click on **[WBM]** at the right in the window.

7.4 Testing the Network Connection

Carry out a ping network function to check whether you can reach the controller at the IP address you have assigned in the network.

1. Open the MS DOS prompt window.
To do this, enter the command “cmd” in the input field under **Start > Execute...** > **Open:** (Windows® XP) or **Start > Search programs/files** (Windows® 7) and then click **[OK]** or press **[Enter]**.
2. In the MS DOS window, enter the command “ping” and the IP address of the controller (for example, ping 192.168.1.17) and then press **[Enter]**.

Note



Host entries in the ARP table!

It may also be useful to delete the current host entries in the ARP table with the command “arp -d *” before executing the “ping” command (as administrator in Windows® 7). This ensures that older entries will not impair the success of the “ping” command.

3. Your PC sends out a query that is answered by the controller. This reply appears in the MS DOS prompt window. If the error message “Timeout” appears, the controller has not responded properly. You then need to check your network settings.

```

C:\WINDOWS\system32\cmd.exe
U:\>ping 192.168.1.17

Ping wird ausgeführt für 192.168.1.17 mit 32 Bytes Daten:

Antwort von 192.168.1.17: Bytes=32 Zeit=1ms TTL=64
Antwort von 192.168.1.17: Bytes=32 Zeit<1ms TTL=64
Antwort von 192.168.1.17: Bytes=32 Zeit<1ms TTL=64
Antwort von 192.168.1.17: Bytes=32 Zeit<1ms TTL=64

Ping-Statistik für 192.168.1.17:
    Pakete: Gesendet = 4, Empfangen = 4, Verloren = 0 (0% Verlust),
    Ca. Zeitangaben in Millisek.:
        Minimum = 0ms, Maximum = 1ms, Mittelwert = 0ms

U:\>_
  
```

Figure 34: Example of a function test

4. If the test is completed successfully, close the MS DOS window.

7.5 Shutdown/Restart

Switch off the power supply to shut down the controller.

To perform a controller restart press and hold the Reset ALL button for more than 7 seconds until all of the LEDs go out.

The controller then performs a restart.

As an alternative, you can switch off the controller and switch it back on again.

A controller restart is signaled by all LEDs briefly lighting up green.

7.6 Initiating Reset Functions

You can initiate various reset functions using the mode selector switch and the Reset button (RST).

7.6.1 Warm Start Reset

The CODESYS 2 application is reset on a warm start reset. This corresponds to the CODESYS 2 IDE command “Reset”.

To perform a warm start reset, set the mode selector switch to "Reset" and hold it there for two to seven seconds.

Execution of the reset is signaled by the red “RUN LED” briefly going out when the mode selector switch is released.

7.6.2 Cold Start Reset

On a cold start reset the CODESYS 2 application is reset and the memory containing the retain variables is cleared.

This corresponds to the CODESYS 2 IDE command “Reset (Cold)”.

To perform a cold start reset, set the mode selector switch to “Reset” and hold it there for more than seven seconds.

Execution of the reset is signaled after seven seconds by the “RUN” LED going out for an extended period. You can then release the mode selector switch.

7.6.3 Software Reset

The controller is restarted on a software reset.

To perform a software reset, set the mode selector switch to RUN or STOP and then press the Reset button (RST) for one to eight seconds.

All LEDs will light up briefly in green to signal reset completion.

7.6.4 Setting a Fixed IP Address

This procedure sets the IP address for the X1 interfaces to the fixed address “192.168.1.17”.

When the switch is enabled, the fixed address is also used for interface X2.

When the switch is disabled, the original address setting for interface X2 is not changed.

No reset is performed.

To make this setting, set the mode selector switch to STOP and press and hold the Reset button (RST) for longer than eight seconds.

Execution of the setting is signaled by the “SYS” LED flashing orange.

To cancel this setting, perform a software reset or switch off the controller and then switch it back on.

7.6.5 Factory Reset

A factory reset restores the device to its initial state on delivery. The controller is then restarted.

Note



Any subsequently installed firmware functions are overwritten!

Firmware functions installed after initial controller startup are overwritten by a factory reset, and the firmware is reset to the version marked on the device. After factory reset, some of the functions described in this manual may no longer be available.

To restore the current operating status, you will need:

- a backup of the currently programmed application,
- the currently installed firmware,
- the manual's version that is applicable to the factory settings.

If you have any questions, feel free to contact our WAGO Support.

To perform a factory reset, set the mode selector switch to “RESET” and press the Reset button (RST) for 1 ... 8 seconds. Briefly release the Reset button (RST) (< 1 second) and press it again until the “U7” LED lights up red. If the “U7” LED lights up red, release the mode selector switch and the Reset button.

After the first 1 ... 8 seconds, the controller reboots (all LEDs light up orange) and after another 3 seconds, the “Factory reset” process begins. The process is indicated by all LEDs lighting up red in succession.

Alternatively, you can also initiate a factory reset when you switch on the controller. Hold the mode selector switch at “RESET” for at least 3 seconds when you switch on the controller and hold the Reset button (RST) down until the “U7” LED lights up red. If the “U7” LED lights up red, release the mode selector switch and the Reset button.

Note



Do not interrupt the reset process!

If you release the Reset button (RST) too soon (after the Reset process), the controller switches to production mode (indicated by a green “U7” LED). If this happens, switch the controller off and then back on again.

Note



Do not switch off!

Do not interrupt, i.e., switch off the controller, during the factory reset process! In other words, do not switch off the controller while this process is in progress!

7.7 Users and Passwords

Several groups of users are provided in the controller which can be used for various services.

Standard passwords are set for all users. We strongly recommend changing these passwords on startup!

Note



Change passwords

Standard passwords are documented in these instructions and therefore do not offer adequate protection! Change the passwords to meet your particular needs.

7.7.1 Services and Users

All password-protected services and their associated users are listed in the following table.

| Service | WBM | | Linux [®] | | | SNMP user |
|--------------------------------|-------|------|--------------------|-------|------|-----------|
| | admin | user | root | admin | user | |
| Web Based Management (WBM) | X | X | | | | |
| Linux [®] console | | | X | X | X | |
| Console Based Management (CBM) | | | X | X | | |
| CODESYS | | | | X | | |
| Telnet | | | X | X | X | |
| FTP | | | X | X | X | |
| FTPS | | | X | X | X | |
| SSH | | | X | X | X | |
| SNMP | | | | | | X |

7.7.2 WBM Group

WBM has its own user administration system. The users in this system are isolated from the other user groups in the system for security reasons.

Detailed information about this is given in the Section “WBM User Administration”.

Table 32: WBM Users

| Users | Permissions | Default Password |
|-------|--------------------------------|------------------|
| admin | All (administrator) | wago |
| user | Supported to a limited extent: | user |
| guest | Display only | --- |

7.7.3 Linux User Group

The Linux[®] users group include the actual users of the operating system, which is likewise used by most services.

The passwords for these users must be configured through a terminal connection via SSH/RS-232.

Table 33: Linux[®] Users

| User | Special Feature | Home Directory | Default Password |
|-------|-----------------|----------------|------------------|
| root | Super user | /root | wago |
| admin | CODESYS user | /home/admin | wago |
| user | Normal user | /home/user | user |

7.7.4 SNMP User Group

The SNMP service manages its own users. In its initial state, no users are stored in the system.

7.8 Configuration

The following methods are available for configuring the PFC200:

- Access to the Web-based management system via the PC using an Internet browser (“Configuration using Web-Based Management (WBM)”)
- Access to the “Console-Based Management” system (CBM) via the PC using a terminal program (via ETHERNET and/or RS-232 interface) (“Configuration using a Terminal Program”)
- Access via the CODESYS PLC program using the WagoConfigToolLIB.lib library (“Appendix” > “WagoConfigToolLIB.lib”)
- Access via the PC using “WAGO Ethernet Settings” (“Configuration using 'WAGO Ethernet Settings'”).

The CBM basically provides the same parameters for configuration of the PFC200 as the WBM, except for parameters which cannot be represented in a useful manner in a terminal window.

For an explanation of these parameters refer to the sections starting at “Information' Page”.

7.8.1 Configuration using Web-Based Management (WBM)

The implemented HTML pages (from here on referred to as “pages”) for Web-Based Management configure the PFC200. Proceed as follows for access the WBM using an Internet browser:

1. Connect the PFC200 to the ETHERNET network via the ETHERNET interface X1.
2. To access the pages, enter the controller's IP address in the address line of your browser followed by “/wbm”, e.g., “http://192.168.1.17/wbm”. Note that the PC and the PFC200 must be located within the same subnet (see Section “Setting an IP Address”). If you do not know the IP address and cannot determine it, switch the controller to the pre-set address “192.168.1.17” using the “Fixed IP address” function (see Section “Initiate Reset Functions” > “Set Fixed IP Address”).

If you have installed a DHCP server on your PC and would like to access WBM through DHCP, use the other interface. You can find detailed information about this in the section “Assigning an IP Address Using DHCP”.

Note



Displaying the PFC200 Start Page

If the PFC200 does not display the start page, ensure that your Internet browser settings permit bypassing the proxy server for local addresses. Also check whether your PC is located in the same subnet as the PFC200.

Note



Take usage by the CODESYS program into account

If the PFC200 is at capacity due to a CODESYS program, this may result in slower processing in the WBM. As a result, timeout errors are sometimes reported under some circumstances. It is therefore important to stop the CODESYS application prior to performing complicated configuration using WBM.

Some pages of the WBM are password protected. The first time you select an item from the navigation bar, the password query appears:

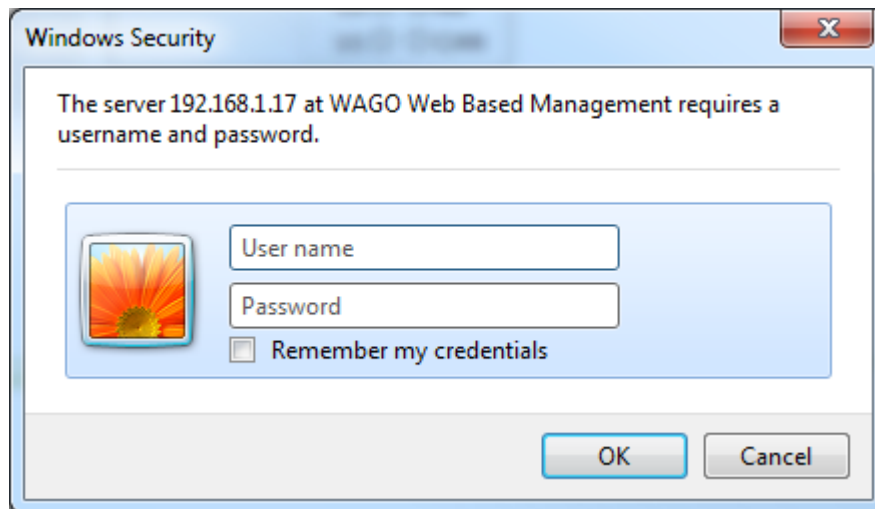

Figure 35: Entering authentication

7.8.1.1 WBM User Administration

To allow settings to be made only by a select number of users, limit access to WBM functions through User Administration.



Note

Change passwords

Standard passwords are documented in these instructions and therefore do not offer adequate protection. Change the passwords to meet your particular needs, see Section “Administration - Users' Page”.

If you do not change the passwords, a warning is displayed on every requested web page after logging in.

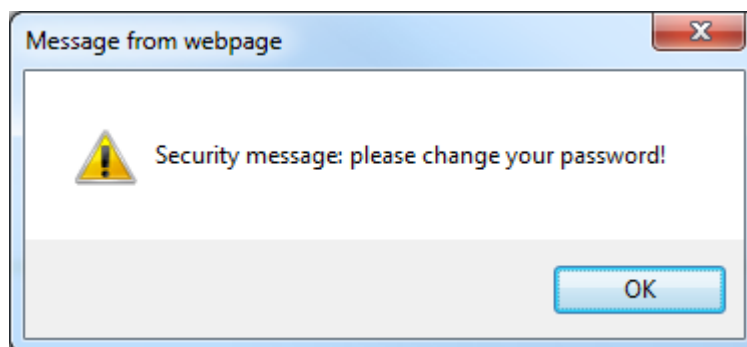

Figure 36: Password reminder

Table 34: User Settings in the Initial State

| Users | Password |
|-------|----------|
| user | user |
| admin | wago |



Note

Observe access rights

Users in WBM are authorized exclusively for access to Web pages. User administration for controller applications is configured separately.

Access to the WBM pages is as follows:

Table 35: Access Rights for WBM Pages

| Navigation | WBM page | User |
|-------------------------|---|-------------|
| Information | Status Information | --- |
| CODESYS | | |
| – Information | CODESYS Information | --- |
| – General Configuration | CODESYS Configuration | user, admin |
| – WebVisu | CODESYS WebVisu | --- |
| Networking | | |
| – Host/Domain Name | Configuration of Network Parameters | user, admin |
| – TCP/IP | TCP/IP Configuration | user, admin |
| – Ethernet | Configuration of Ethernet Parameters | user, admin |
| Clock | Configuration of Date and Time | user, admin |
| Administration | | |
| – Users | Configuration of the users for the Web-based Management | admin |
| – Create Image | Create bootable Image | admin |
| – Serial Interface | Configuration of Serial Interface RS233 | admin |
| – Reboot | Reboot Controller | admin |
| Package Server | | |
| – Firmware Backup | Firmware Backup | admin |
| – Firmware Restore | Firmware Restore | admin |
| – System Partition | System Partition | admin |
| Mass Storage | Mass Storage | admin |
| Software Uploads | Software Uploads | admin |
| Ports and Services | | |
| – Network Services | Configuration of Network Services | user, admin |
| – NTP Client | Configuration of NTP Client | user, admin |
| – CODESYS Services | Configuration of the CODESYS Services | user, admin |
| – SSH | SSH Client Settings | user, admin |
| – TFTP | TFTP Server | user, admin |
| SNMP | | |
| – General Configuration | Configuration of SNMP parameter | admin |
| – v1/v2c | Configuration of SNMP parameter | admin |
| – v3 | Configuration of SNMP v3 Users | admin |
| Diagnostic | Diagnostic Information | --- |

7.8.1.2 General Information about the Page

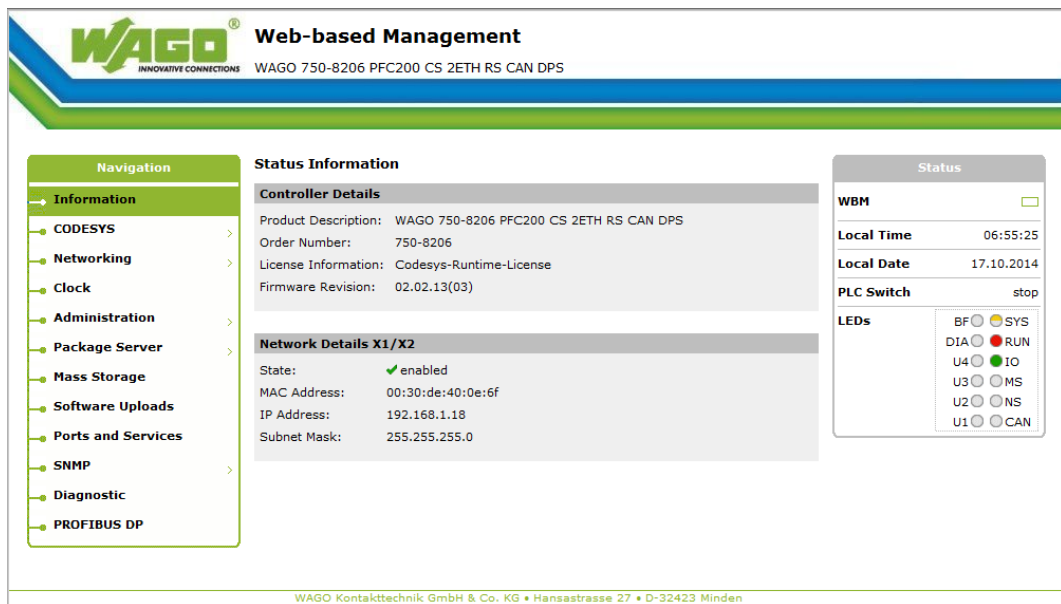

Figure 37: WBM browser window (example)

The device name is displayed in the header of the browser window.

The navigation tree is shown at the left edge of the browser window. You can use this navigation tree to go to the individual pages and, where provided, subpages included in these pages.

A status area with the following elements is displayed at the right edge:

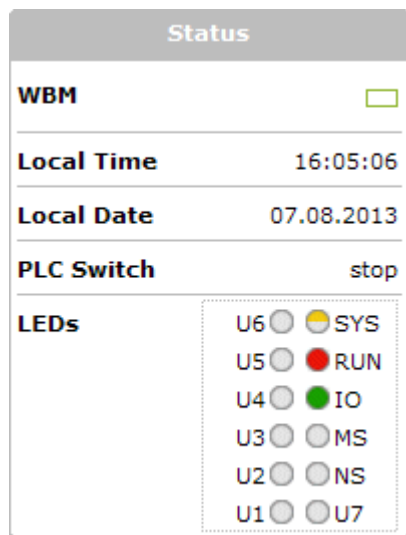

Figure 38: WBM status information (example)

- **WBM status:**
Here, you can recognize whether the WBM is currently communicating with the device in the background, i.e., one or more queries have been sent and the browser is waiting on a response. Movement is then visible in the graphic. This occurs when data are read on initial call-up of the page, when

the user has sent off a change form or when data is reloaded automatically in cycles, e.g., the contents of the status area.

- Local Time:
Local time on the device
- Local Date:
Local date on the device
- PLC Switch:
Setting of the mode selector switch
- LEDs:
Here, the the status of the device LEDs is indicated. All of the LEDs are symbolized by a diagram and are labeled with their particular designation (e.g., SYS, RUN, etc.). The following colors may be used:

- gray:
LED is off

- full color (green, red, yellow, orange):
The LED is activated in the particular color

- half color:
The LED is flashing in the corresponding color. The other half of the surface is then either gray or also colored. The latter case indicates that the LED is flashing sequentially in different colors.

A tool tip containing more detailed information opens as long as the cursor is positioned over an LED. The text that is displayed also contains the message that put the LED into its current status. The time of the message is also shown.

The statuses displayed in the WBM will not always correspond at the precise time to those on the PFC200. Data has a runtime during transmission and can only be queried at a certain interval. The time period between two queries is 30 seconds.

The contents of the individual pages and sub-pages are explained in the following sections.

7.8.1.3 “Status Information” Page

The following tables explain the parameters listed on this page:

7.8.1.3.1 “Controller Details” Group

Table 36: WBM “Status Information” page – “Controller Details” group

| Parameters | Explanation |
|---------------------|---|
| Product Description | Controller identification |
| Order Number | Item number of the controller |
| License Information | Notification that the CODESYS runtime system is available |
| Firmware Revision | Firmware status |

7.8.1.3.2 “Network Details (Xn)” Group(s)

If the switch is enabled, one group (“Network Details”) is shown for both connections.

If the switch is disabled, one group (“Network Details X1” / “Network Details X2”) is shown for each connection.

Table 37: WBM “Status Information” page – “Network Details (Xn)” group(s)

| Parameters | Explanation |
|-------------|---|
| State | Status of the ETHERNET interface (enabled/disabled) |
| Mac Address | MAC address identifies and addresses the controller |
| IP Address | Current IP address of the controller |
| Subnet Mask | Current subnet mask of the controller |

7.8.1.4 “CODESYS Configuration” Page

The settings for the boot project created in CODESYS are shown on the “CODESYS Configuration” page.

7.8.1.4.1 “General Configuration” Group

Table 38: WBM “CODESYS Configuration” page – “General Configuration” group

| Display Fields | Explanation | |
|-----------------|---|--|
| CODESYS Version | Select which CODESYS version you want to activate. | |
| | None | CODESYS is not active. |
| | 2 | CODESYS version 2 is active. |
| (Boot Device) | Select the storage medium the boot project will be stored on. | |
| | Memory Card | The boot project is stored on the memory card. |
| | Internal Flash | The boot project is stored in the internal flash memory. |

Note



“Internal Flash” is not always available!

The boot project can only be stored in the internal flash memory when the operating system has been started from the internal flash.

If the operating system has been started from the memory card, the “Internal Flash” option is not available.

Click [**Submit**] to apply change. The change is effective immediately.

Note



Restart the controller after changing this setting!

Restart the controller after changing the setting to ensure that any files still open are switched over correctly.

7.8.1.5 “CODESYS Information” Page

All information about the PLC program created in CODESYS is provided on the “CODESYS Information” page.

7.8.1.5.1 “CODESYS” Group

Table 39: WBM “CODESYS – Information” page – “CODESYS” group

| Display Fields | Explanation | |
|-----------------|--|------------------------------|
| Version | The version of the CODESYS runtime system currently active is shown (if the runtime system is disabled, “None” is displayed and the subsequent fields of this group are disabled). | |
| Version Number | The version number of the CODESYS Web server is shown. This field is only visible when CODESYS is enabled. | |
| CODESYS State | The operating status of CODESYS is shown. This field is only visible when CODESYS is enabled. | |
| | STOP | PLC program is not executed. |
| | RUN | PLC program is executed. |
| Number of Tasks | The number of tasks in the CODESYS program is shown. This field is only visible when CODESYS is enabled. | |

7.8.1.5.2 “Project Details” Group

Table 40: WBM “CODESYS Information” page – “Project Details” group

| Display Fields | Explanation |
|----------------|--|
| Date | Display of project information that the programmer entered in the PLC program (in CODESYS under Project > Project Information...). |
| Title | |
| Version | |
| Author | |
| Description | |
| | The information only appears in an executed PLC program. |
| | Descriptive texts up to 1024 characters long are given under “Description.” |

7.8.1.5.3 "Task n" Group(s)

One dedicated group is displayed for each task when the PLC program is executed. As a rule, only the group title is displayed with the task number, the task name and the task ID.

Click [+] to expand the group and display the following information.

Table 41: WBM “CODESYS Information” page – “Task n” group(s)

| Display Field | Explanation |
|-----------------------|--|
| Cycle count | Number of task cycles since system start |
| Cycle time (µsec) | Currently measured task cycle time |
| Cycle time min (µsec) | Minimum task cycle time since system start |
| Cycle time max (µsec) | Maximum task cycle time since system start |
| Cycle time avg (µsec) | Average task cycle time since system start |
| Status | Task status (e.g., RUN, STOP) |
| Mode | Task execution mode (e.g., in cycles) |
| Priority | Set task priority |
| Interval (msec) | Set task interval |

To hide this information, click [-].

7.8.1.6 “CODESYS WebVisu” Page

The settings for the Web visualization created in CODESYS are shown on the “CODESYS WebVisu” page.

7.8.1.6.1 “Webserver Configuration” Group

Table 42: WBM “CODESYS WebVisu” page – “Webserver Configuration” group

| Display Fields | Explanation | |
|-------------------------|---|---|
| CODESYS Webserver State | The status (enabled/disabled) of the CODESYS Web server is displayed here. | |
| Default Webserver | Choose whether the Web-based Management or CODESYS Web visualization should be displayed when only entering the IP address of the controller. | |
| | Web-based Management | The Web-based Management is displayed. |
| | CODESYS WebVisu | The CODESYS Web visualization is displayed. |

Click [**Submit**] to apply change. The change is effective immediately.

In its default setting, the WBM is called up when only entering the IP address.

To update the display after switching, enter the IP address again in the address line of the Web browser.

To display the Web visualization, the CODESYS Web server must be enabled (in WBM under “Ports and Services” -> “CODESYS Services”) and there must be a suitably configured CODESYS application.

Regardless of the default Web browser setting, the WBM can be called up at any time with “http://<IP address>/wbm” and the Web visualization with “http://<IP address>/webvisu”.

You can obtain additional information on CODESYS Web visualization in the chapter with the same name.

Note



Possible error messages when calling up the Web visualization

The “500 – Internal Server Error” message indicates that the CODESYS Web server is not enabled.

A page with the header “WebVisu not available” means that no CODESYS application has been loaded in the controller using Web visualization.

7.8.1.7 “Configuration of Network Parameters” Page

The settings for the general TCP/IP parameters are found on the “Configuration of Network Parameters” page.

7.8.1.7.1 “Hostname” Group

Table 43: WBM “Configuration of Network Parameters” page – “Hostname” group

| Parameters | Explanation |
|----------------|--|
| Currently used | If you have selected dynamic assignment of an IP address via DHCP, the name of the host currently being used is displayed. |
| Configured | Enter the host name of the PC that will be used after a controller restart. |

Click [**Submit**] to apply the change. The change becomes effective after the next controller reboot.

7.8.1.7.2 “Domain Name” Group

Table 44: WBM “Configuration of Network Parameters” page – “Domain Name” group

| Parameters | Explanation |
|-------------|---------------------------|
| Domain Name | Set the domain name here. |

Click [**Submit**] to apply change. The change is effective immediately.

7.8.1.8 “TCP/IP Configuration” Page

The TCP/IP settings for the ETHERNET interfaces are shown on the “TCP/IP configuration” page.

7.8.1.8.1 “Switch Configuration” Group

Table 45: WBM “TCP/IP Configuration” page – “Switch Configuration” group

| Parameters | Explanation | |
|------------|-------------------------------|---|
| Interfaces | Enable or disable the switch. | |
| | Switched | Both interfaces are operated with one IP address. |
| | Separated | Each interface is operated with its own IP address. |

Click [**Submit**] to apply change. The change is effective immediately.

7.8.1.8.2 “IP Address (Xn)” Group(s)

If the switch is enabled, one group (“IP Address”) is shown for both connections. If the switch is disabled, one group (“IP Address X1” / “IP Address X2”) is shown for each connection.

Table 46: WBM “TCP/IP Configuration” page – “IP Address (Xn)” group(s)

| Parameters | Explanation | |
|--------------------|---|-----------------------|
| Configuration Type | Select a static or dynamic IP address. | |
| | Static IP | Static IP addressing |
| | DHCP | Dynamic IP addressing |
| | BootP | Dynamic IP addressing |
| IP Address | Here, enter a static IP address. This is active if “Static IP” is activated in the Configuration Type field. | |
| Subnet Mask | Enter the subnet mask here. This is active if “Static IP” is activated in the Configuration Type field. | |

Click [**Submit**] to apply changes. The change is effective immediately.

7.8.1.8.3 “Default Gateway” Group

Table 47: WBM “TCP/IP Configuration” page – “Default Gateway” group

| Parameters | Explanation | |
|--|--|---|
| State This field is only visible when the switch is enabled. | Specify if you will use the standard gateway. The controller uses the standard gateway when the target address is located outside of its own network. | |
| | Disabled | The standard gateway is not used. |
| | Enabled | The standard gateway is used. |
| Interface This field is only visible when the switch is disabled. | Choose which connection you will use for the standard gateway. The controller uses the standard gateway when the target address is located outside of its own network. | |
| | None | The standard gateway is not used. |
| | X1 | The standard gateway is used for connection X1. |
| | X2 | The standard gateway is used for connection X2. |
| Gateway | Enter the address of the standard gateway here. | |

Note



Set a maximum of one standard gateway!

If the standard gateway is specified via the DHCP server, a maximum of one standard gateway can be set in “Separated” mode for all combinations (“DHCP”/“Static”, “DHCP”/“DHCP”, etc.).

Click [**Submit**] to apply change. The change is effective immediately.

7.8.1.8.4 “DNS Server” Group

Table 48: WBM “TCP/IP Configuration” page – “DNS Server” group

| Parameters | Explanation |
|----------------------|--|
| DNS Server 1, 2, ... | The addresses of the defined DNS servers are displayed here. If no server has been defined, “Configured: None” is displayed. |
| New server IP | Add additional DNS addresses here. |

Click [**Delete**] to remove the selected DNS server. The change is effective immediately.

Click [**Add**] to add the entered DNS server. The change is effective immediately.

7.8.1.9 “Configuration of ETHERNET Parameters” Page

The ETHERNET TCP/IP settings are shown on the “Configuration of ETHERNET” page.

7.8.1.9.1 “Interface Xn” Groups

One group (“Interface X1” / “Interface X2”) is displayed for each connection.

Table 49: WBM “Configuration of ETHERNET Parameters” page – “Interface Xn” groups

| Parameters | Explanation | |
|----------------------|--|--|
| Enabled | You can enable or disable the interface. | |
| Autonegotiation on | When Autonegotiation is activated, the connection modalities are negotiated automatically with the peer devices. | |
| Speed/Duplex | Select the transmission speed and the duplex method: | |
| | 10 Mbit half-duplex | Information can only be sent or received. |
| | 100 Mbit half-duplex | |
| | 10 MBit full-duplex | Information can be sent and received simultaneously. |
| 100 Mbit full-duplex | | |

Click [**Submit**] to apply changes. The change is effective immediately.

7.8.1.10 “Configuration of Time and Date” Page

The settings for date and time are shown on the “Configuration of Time and Date” page.

7.8.1.10.1 “Date on Device” Group

Table 50: WBM “Configuration of Time and Date” page – “Date on Device” group

| Parameters | Explanation |
|------------|----------------|
| Local | Set date here. |

Click [**Change date**] to apply change. The change is effective immediately.

7.8.1.10.2 “Time on Device” Group

Table 51: WBM “Configuration of time and date” page – “Time on Device” group

| Parameters | Explanation |
|-------------|---|
| Local | Set local time. |
| UTC | Set GMT time. |
| 12 h format | For switching between 12-hour and 24-hour time display. |

Click [**Change time**] to apply change to the time. The change is effective immediately.

Click [**Change format**] to apply change to the time format. The change is effective immediately.

7.8.1.10.3 “Time Zone” Group

Table 52: WBM “Configuration of time and date” page – “Time Zone” group

| Parameters | Explanation | |
|------------|--|---|
| Time Zone | Specify the appropriate time zone for your location. Default setting: | |
| | AST/ADT | “Atlantic Standard Time”, Halifax |
| | EST/EDT | “Eastern Standard Time”, New York, Toronto |
| | CST/CDT | “Central Standard Time”, Chicago, Winnipeg |
| | MST/MDT | “Mountain Standard Time”, Denver, Edmonton |
| | PST/PDT | “Pacific Standard Time”, Los Angeles, Whitehouse: |
| | GMT/BST | “Greenwich Mean Time”, GB, P, IRL, IS, ... |
| | CET/CEST | “Central European Time”, B, DK, D, F, I, CRO, NL, ... |
| | EET/EEST | “East European Time”, BUL, FI, GR, TR, ... |
| | CST | “China Standard Time” |
| | JST | “Japan/Korea Standard Time” |

Click [**Change**] to apply time zone change. The change is effective immediately.

7.8.1.10.4 “TZ String” Group

Table 53: WBM “Configuration of time and date” page – “TZ String” group

| Parameters | Explanation |
|------------|--|
| TZ String | Enter your time zone if it is not available from the “Time Zone” parameter list. An overview of all time zones is available at http://home.tiscali.nl/~t876506/TZworld.html with information about editing the TZ string in Linux [®] at http://www.minix-vmd.org/pub/Minix-vmd/1.7.0/wwwman/man5/TZ.5.html . |

Click [**Change**] to apply the change. The change is effective immediately.

7.8.1.11 “Configuration of the Users for the Web-based Management” Page

The settings for user administration are shown on this page.

7.8.1.11.1 “Change Password for Selected User” Group

Table 54: WBM “Configuration of the users for the Web-based Management” page – “Change Password for selected user” group

| Parameters | Explanation |
|------------------|--|
| Select User | Select the user (“user” or “admin”) for new password assignment. |
| New Password | Enter the new password for the user selected under “Select User”. The following ASCII characters for passwords are valid: a ... z, A ... Z, 0 ... 9 and spaces. These special characters are also valid:]!"#\$%&'()*+,-./:;<=>?@[^_`{ }~-- |
| Confirm password | Enter the new password again for confirmation. |

Click [**Change Password**] to apply change. The change is effective immediately.

Note



Observe the valid characters for WBM passwords!

If WBM passwords with invalid characters are set outside the WBM system (e.g. via CBM), then accessing the WBM pages is no longer possible!

Note



Observe access rights

Authorized WBM users only have access to the Web pages. User administration for controller applications is configured separately.

7.8.1.12 “Create Bootable Image” Page

You can create a bootable image on the “Create Bootable Image” page.

7.8.1.12.1 "Create Bootable Image from Active Partition (<Active Partition>" Group

The active partition that boot-up was performed from is displayed in brackets in the heading.

Table 55: WBM “Create Bootable Image” page – “Create bootable image from active partition” group

| Parameters | Explanation | | |
|-------------|--|---|---------------------------------------|
| Destination | The possible destination partition that an image will be saved to is displayed. Depending on which medium has been booted, the following destination is available for selection after boot-up for the image to be generated: | | |
| | System was booted from | | Target partition for “bootable image” |
| | Memory Card | → | Internal Flash |
| | Internal Flash | → | Memory Card |

Once the destination has been determined and output, it is then checked and the results of this check are displayed below the settings:

- Free space on the target device:
If the available memory is less than 5 %, a warning is displayed. You can still start the copy process despite the warning. If the available space is definitively too low, a corresponding message is displayed and copying cannot be started.
- Device being used by CODESYS:
If the device is being used by CODESYS a warning is displayed. Although it is not recommended, you can still start the copying procedure despite this warning.

Click **[Start Copy]** to start the copying procedure. If the outcome of the test is positive, copying begins immediately. If errors have been detected, a corresponding message is displayed and copying is not started. If warnings have been issued, these are displayed again and you must then confirm that you still wish to continue.

Note



Remove the memory card write protection!

Because write access to the memory card is possible during the boot process, the memory card cannot be write protected when creating the image and during operation.

7.8.1.13 “Configuration of Serial Interface RS232” Page

The settings for the serial interface are shown on the “Configuration of Serial Interface RS232” page.

7.8.1.13.1 “Serial Interface Assigned to” Group

The application that the serial interface is currently assigned to is displayed.

7.8.1.13.2 “Assign Owner of Serial Interface (Active after Next Controller Reboot)” Group

You can specify the application that the serial interface is to assigned after the next controller reboot.

Table 56: WBM “Configuration of Serial Interface RS232” page – “Assign Owner of serial Interface” group

| Parameters | Explanation |
|--|--|
| Linux [®] Console | Specify that the serial interface is assigned to the Linux [®] console. |
| Unassigned (usage by applications, libraries, CODESYS) | Specify that the serial interface is not to be assigned to any particular application and is available, so that the CODESYS program, for example, can access it via function blocks. |

NOTICE

Remove RS-485 devices before switching to “Linux Console”!

Connected RS-485 devices can be damaged when switching to “Linux Console”.
Remove these devices before switching!

Click [**Change Owner**] to apply the change. The change takes effect after the next controller reboot.

7.8.1.14 “Reboot Controller” Page

The settings for the system reboot are shown on the “Reboot Controller” page.

7.8.1.14.1 “Reboot Controller” Group

Click the [Reboot] button to reboot the system.



Note

Account for boot-up time!

The boot process takes time. You cannot access the PFC200 while this is occurring.

7.8.1.15 “Firmware Back-up” Page

The settings for a firmware backup are shown on the “Firmware Backup” page.

Select the packages to be restored in the **Packages** group. Select the corresponding entries.

Note



Only one package may be copied to the network!

If you have specified “Network” as the storage location, only one package may be selected for each storing process.

In the selection box **Destination**, select the target storage location.

Note



No backup of the memory card!

Backup from the memory card to the internal flash memory is not possible.

To activate the automatic update function mark check box **Activate “auto update feature”**.

Note



Account for backup time

Generation of backup files can take several minutes. Stop the CODESYS program before you start the backup procedure to help shorten the time required.

To begin the backup procedure, click the **[Submit]** button.

7.8.1.16 “Firmware Restore” Page

The settings for restoring the firmware are shown on the “Firmware Restore” page.

In the **Source** selection box, select the storage location.

Select the packages to be restored in the **Packages** group. Select the corresponding entries.

In the **CODESYS backup file** input field, enter the name of the backup file for the CODESYS project or click the **[Browse]** button to select the file in Explorer.

In the **Settings backup file** input field, enter the name of the backup file for the settings or click the **[Browse]** button to select the file in Explorer.

In the **System backup file** input field, enter the name of the backup file for the system data or click the **[Browse]** button to select the file in Explorer.

Note



Reset by restore

A reset is performed when the system or settings are restored by CODESYS!

To start the restore procedure, click the **[Submit]** button.

7.8.1.17 “System Partition” Page

The settings for specifying the partition that the system will be started from are shown on the “System Partition” page.

7.8.1.17.1 “Current Active Partition” Group

The partition currently in use is displayed here.

7.8.1.17.2 “Set Inactive Partition Active” Group

Click [**Activate Partition**] to start the system from a different partition at the next controller reboot.

Note



Ensure bootable partition!

A functional firmware backup must be present in the boot partition!

Note



Remove the memory card write protection!

Because write access to the memory card is possible during the boot process, the memory card cannot be write protected when operated as the active partition.

7.8.1.18 “Mass Storage” Page

A group containing information about the storage volume is displayed for each storage volume that is found, along with an additional group for formatting (when this is possible).

The group title contains the designation for the storage volume (“SD card” or “Internal Flash”) and, if this storage volume is also the active partition, the text “Active Partition”.

7.8.1.18.1 “<Device Name>” Group(s)

Table 57: WBM “Mass Storage” page – “<Device Name>” group

| Parameters | Explanation |
|-------------|---|
| Device | The name of the storage volume in the operating system file system is displayed here. |
| Volume name | The name of the storage volume is displayed here. |

7.8.1.18.2 “<Device Name> - FAT Format” Group(s)

Table 58: WBM “Mass Storage” page – “<Device Name>” group

| Parameters | Explanation |
|-------------|---|
| Volume Name | Specify the name for the storage volume when formatted. |

Note



Data are deleted!

Any data stored in the storage volume is deleted during formatting!

To format the specified storage volume, click **[Start Formatting]**.

7.8.1.19 “Software Uploads” Page

The settings for a device update are shown on the “Software uploads” page.

7.8.1.19.1 “Upload New Software” Group

Table 59: WBM “Software Uploads” page – “Upload New Software” group

| Parameters | Explanation |
|----------------|---|
| (Package File) | You can select fieldbus software, program licenses and update scripts, for example, for transfer from a PC to the controller. |

To select a file on the PC, click the [**Browse**] button.

To transfer the selected file to the controller, click [**Start Upload**] button.

7.8.1.19.2 “Activate New Software” Group

Table 60: WBM “Software Uploads” page – “Activate New Software” group

| Parameters | Explanation |
|----------------|--|
| (Package File) | The file name of the software package to be transferred is displayed here, with a button on the right for activation. If no new, uploaded software package is available on the controller, the message “No upload file exists” is displayed. |

To activate the uploaded software package, click the [**Activate**] button. The process starts immediately.

The file with the software package is deleted on completion of the installation procedure.

7.8.1.20 “Configuration of Network Services” Page

The settings for various services are shown on the “Configuration of Network Services” page.

7.8.1.20.1 “Telnet” Group

Table 61: WBM “Configuration of Network Services” page – “Telnet” group

| Parameters | Explanation |
|------------------|---|
| enabled/disabled | Indicates if the Telnet service is enabled. |

Click **[Disable]/[Enable]** to change the status of the service. The change is effective immediately.

7.8.1.20.2 “FTP” Group

Table 62: WBM “Configuration of Network Services” page – “FTP” group

| Parameters | Explanation |
|------------------|--|
| enabled/disabled | Indicates if the FTP service is enabled. |

Click **[Disable]/[Enable]** to change the status of the service. The change is effective immediately.

7.8.1.20.3 “FTPS” Group

Table 63: WBM “Configuration of Network Services” page – “FTPS” group

| Parameters | Explanation |
|------------------|---|
| enabled/disabled | It is displayed if the FTPS service is enabled. |

Click **[Disable]/[Enable]** to change the status of the service. The change is effective immediately.

7.8.1.20.4 “HTTP” Group

Table 64: WBM “Configuration of Network Services” page – “HTTP” group

| Parameters | Explanation |
|------------------|---|
| enabled/disabled | It is displayed if the HTTP service is enabled. |

Click **[Disable]/[Enable]** to change the status of the service. The change is effective immediately.

7.8.1.20.5 “HTTPS” Group

Table 65: WBM “Configuration of Network Services” page – “HTTPS” group

| Parameters | Explanation |
|------------------|--|
| enabled/disabled | It is displayed if the HTTPS service is enabled. |

Click **[Disable]/[Enable]** to change the status of the service. The change is effective immediately.

7.8.1.21 “Configuration of NTP Client” Page

The settings for the NTP service are shown on the “Configuration of NTP Client” page.

7.8.1.21.1 “NTP Client” Group

Table 66: WBM “Configuration of NTP Client” page – “NTP Client” group

| Parameters | Explanation |
|-------------------|---|
| Service enabled | Activate/deactivate time update. |
| Port | Enter the port number for the NTP access (default setting: 123) |
| Time Server | Enter the IP address of the time server. |
| Update Time (sec) | Specify the time server query cycle. |

Click the [**Submit**] button to apply the changes. The change is effective immediately.

7.8.1.22 “Configuration of the CODESYS Services” Page

The settings for various CODESYS services are shown on the “Configuration of the CODESYS Services” page.

7.8.1.22.1 “CODESYS Webserver” Group

Table 67: WBM “Configuration of the CODESYS Services” page – “CODESYS Webserver” group

| Parameters | Explanation |
|---------------|---|
| Current State | The CODESYS Web server status is displayed. |

Click **[Disable]/[Enable]** to change the status of the service. The change is effective immediately.

7.8.1.22.2 “Communication” Group

Table 68: WBM “Configuration of the CODESYS Services” page – “Communication” group

| Parameters | Explanation |
|---------------|---------------------------------------|
| Current State | The CODESYS status is displayed. |
| Port Number | The CODESYS port number is displayed. |

Click **[Disable]/[Enable]** to change the status of the service. The change is effective immediately.

Click **[Change]** to change the port number. The change is effective immediately.

7.8.1.22.3 “Port Authentication” Group

Table 69: WBM “Configuration of the CODESYS Services” page – “Port Authentication” group

| Parameters | Explanation |
|---------------|--|
| Current State | Displays if port authentication is activated. If authentication is “enabled”, a password is required to access the port. |

Click **[Disable]/[Enable]** to activate/deactivate port authentication. The change is effective immediately.

7.8.1.22.4 “Port Authentication Password” Group

Table 70: WBM “Configuration of the CODESYS Services” page – “Port Authentication Password” group

| Parameters | Explanation |
|------------------|--|
| New Password | Specify the password for port authentication. |
| Confirm password | Enter the new password again for confirmation. |

Click **[Change]** to change the password. The change is effective immediately.

7.8.1.23 “SSH Client Settings” Page

The settings for the SSH service are shown on the “SSH Client Settings” page.

7.8.1.23.1 “SSH Client” Group

Table 71: WBM “SSH Client Settings” page – “SSH Client” group

| Parameters | Explanation |
|----------------------|--|
| Current state | You can enable/disable the SSH client. |
| Port Number | Specify the port number. |
| Allow root login | You can enable or inhibit root access. |
| Allow password login | Activate or deactivate the password query function here. |

Click **[Disable]**/**[Enable]** to change the status of the service. The change is effective immediately.

Click the **[Submit]** button to apply the other changes. The change is effective immediately.

7.8.1.24 “TFTP Server” Page

The settings for the TFTP service are shown on the “TFTP Server” page.

7.8.1.24.1 “TFTP Server” Group

Table 72: WBM “TFTP Server” page – “TFTP Server” group

| Parameters | Explanation |
|--------------------|--|
| Current state | Activate or deactivate the TFTP server. |
| Download directory | Specify the path for downloading the server directory. |

Click [**Disable**]/[**Enable**] to change the status of the service. The change is effective immediately.

Click the [**Submit**] button to apply the other changes. The change is effective immediately.

7.8.1.25 “Configuration of SNMP parameter” Page

The general settings for SNMP are shown on the “Configuration of SNMP parameter” page.

7.8.1.25.1 “General SNMP Configuration” Group

Table 73: WBM “Configuration of SNMP parameter” page – “General SNMP Configuration” group

| Parameters | Explanation |
|------------------------------------|--|
| Current state: enabled/disabled | Here, the actual state of the SNMP service is displayed. |
| Name of device | Enter the device name (sysName) here. |
| Description | Enter the device description (sysDescription) here. |
| Physical location | Enter the device location (sysLocation) here. |
| Contact | Enter the email contact address (sysContact) here. |

Click [**Disable/Enable**] to change the state of the SNMP service. Click [**Change**] to apply any further changes. The changes do not become effective until after the next software or hardware reset.

7.8.1.26 “Configuration of SNMP Parameter” Page

The general settings for SNMP v1/v2c are shown on the “Configuration of SNMP parameter” page.

7.8.1.26.1 “SNMP v1/v2c Manager Configuration” Group

Table 74: WBM “Configuration of SNMP parameter” page – “SNMP v1/v2c Manager Configuration” group

| Parameters | Explanation |
|----------------------|--|
| Protocol enabled | It is displayed the SNMP protocol for v1/v2c is activated. The local community name is deleted when the protocol is deactivated. |
| Local Community Name | Here, specify the community name for the SNMP manager configuration. The community name can establish relationships between SNMP managers and agents who are respectively referred to as “Community” and who control identification and access between SNMP participants. The community name can be up to 32 characters long and may not include spaces. To use the SNMP protocol, a valid community name must always be specified. |

Click [**Change**] to apply changes. The changes do not become effective until after the next software or hardware reset.

7.8.1.26.2 “Actually Configured Trap Receivers” Group(s)

Table 75: WBM “Configuration of SNMP parameter” page – “Actually Configured Trap Receivers” group

| Parameters | Explanation |
|------------|---|
| Count | The number of configured trap receivers is displayed. |

7.8.1.26.3 “Trap Receiver n” Group(s)

A dedicated group with the following information is displayed for each trap receiver:

Table 76: WBM “Configuration of SNMP parameter” page – “Trap Receiver n” group

| Parameters | Explanation |
|----------------|---|
| IP Address | The IP address of the trap receiver (management station) is displayed. |
| Community Name | The community name for the trap receiver configuration is displayed here. The community name can be evaluated by the trap receiver. |
| Version | The SNMP version, via which the traps are sent, is displayed here: v1 or v2c (traps higher than v3 are displayed in a separate form). |

Click **[Delete]** to delete the trap receiver. The changes do not become effective until after the next software or hardware reset.

7.8.1.26.4 “Add new Trap Receiver” Group

Table 77: WBM “Configuration of SNMP parameter” page – “Add new Trap Receiver” group

| Parameters | Explanation |
|----------------|--|
| IP Address | Enter the IP address of the new trap receiver (management station). |
| Community Name | Here, specify the community name for the new trap receiver configuration. The community name can be evaluated by the trap receiver. The community name can be up to 32 characters long and may not include spaces. |
| Version | Specify the SNMP version that will send the traps: v1 or v2c (traps higher than v3 are configured in a separate form). |

Click **[Add]** to add a new trap receiver. The changes do not become effective until after the next software or hardware reset.

7.8.1.27 “Configuration of SNMP v3 Users” Page

The general settings for SNMP v3 are shown on the “Configuration of SNMP v3 Users” page.

7.8.1.27.1 “Actually Configured v3 Users” Group(s)

Table 78: WBM “Configuration of SNMP v3” page – “Actually Configured v3 Users” group

| Parameters | Explanation |
|------------|---|
| Count | The number of configured v3 users is displayed. |

7.8.1.27.2 “v3 User n” Group(s)

A group with the following information is displayed for each user:

Table 79: WBM “Configuration of SNMP v3 Users” page – “v3 User n” group(s)

| Parameters | Explanation |
|---------------------------------------|--|
| Security Authentication Name | The user name is displayed. |
| Authentication Type | The authentication type for the SNMP v3 packets is displayed here. Possible values: - Use no authentication (“None”) - Message Digest 5 (“MD5”) - Secure Hash Algorithm (“SHA”) |
| Authentication Key (min. eight char.) | The authentication key is displayed. |
| Privacy | The encryption algorithm for the SNMP message is displayed here. Possible values: - No encryption (“None”) - Data Encryption Standard (“DES”) - Advanced Encryption Standard (“AES”) |
| Privacy Key (min. eight char.) | The key for encryption of the SNMP message is displayed here. If nothing is displayed here, the “authentication key” is automatically used. |
| Notification Receiver IP | The IP address of a trap receiver for v3 traps is displayed here. If no v3 traps are to be sent for this user, this field remains blank. |

Click **[Delete]** to delete the user. The changes do not become effective until after the next software or hardware reset.

7.8.1.27.3 “Add New v3 User” Group

Table 80: WBM “Configuration of SNMP v3 Users” page – “Add new v3 User” group

| Parameters | Explanation |
|---------------------------------------|---|
| Security Authentication Name | Enter the user name here. This name must be unique; a pre-existing user name is not accepted when entered here. The security authentication name can have a maximum 32 characters, without any spaces. |
| Authentication Type | Specify the authentication type for the SNMP v3 packets. Possible values: - Use no authentication (“None”) - Message Digest 5 (“MD5”) - Secure Hash Algorithm (“SHA”) |
| Authentication Key (min. eight char.) | Specify the authentication key here. This authentication key must have between eight and 32 characters, without any spaces. |
| Privacy | Specify the encryption algorithm for the SNMP message here. Possible values: - No encryption (“None”) - Data Encryption Standard (“DES”) - Advanced Encryption Standard (“AES”) |
| Privacy Key (min. eight char.) | Enter the key for encryption of the SNMP message here. If nothing is specified here, the “authentication key” is automatically used. The privacy key must have between eight and 32 characters, without any spaces. |
| Notification Receiver IP | Specify an IP address for a trap receiver for v3 traps here. If no v3 traps are to be sent for this user, this field remains blank. |

Click [**Add**] to add a new user. The changes do not become effective until after the next software or hardware reset.

7.8.1.28 “Diagnostic Information” Page

The settings for displaying diagnostics messages are shown on the “Diagnostic Information” page.

Table 81: WBM “Diagnostic Information” page

| Parameters | Explanation |
|-------------------------------|--|
| Read all notifications | Activate display of all messages. |
| Read only the last n | Activate display of only the last n messages. You also specify the number of messages to be displayed. |
| Automatic refresh cycle (sec) | Select the check box to enable cyclic refresh. Enter the cycle time in seconds when a cyclic refresh is performed. If cyclic refresh is enabled, the button label changes to “Stop”. |

To refresh the display or to enable cyclic refresh, click the **[Refresh]** button. The button is only visible if cyclic refresh is disabled.

To stop cyclic refresh again, click the **[Stop]** button. The button is only visible if cyclic refresh is enabled.

The messages are displayed below the settings.

7.8.2 Configuration using a Terminal Program (CBM)

You can configure the PFC200 both via ETHERNET using ssh and via the Linux[®] console using the RS-232 interface via CBM. To call up the CBM log in to both variants at the Linux[®] console and enter the command “cbm” (case sensitive!).

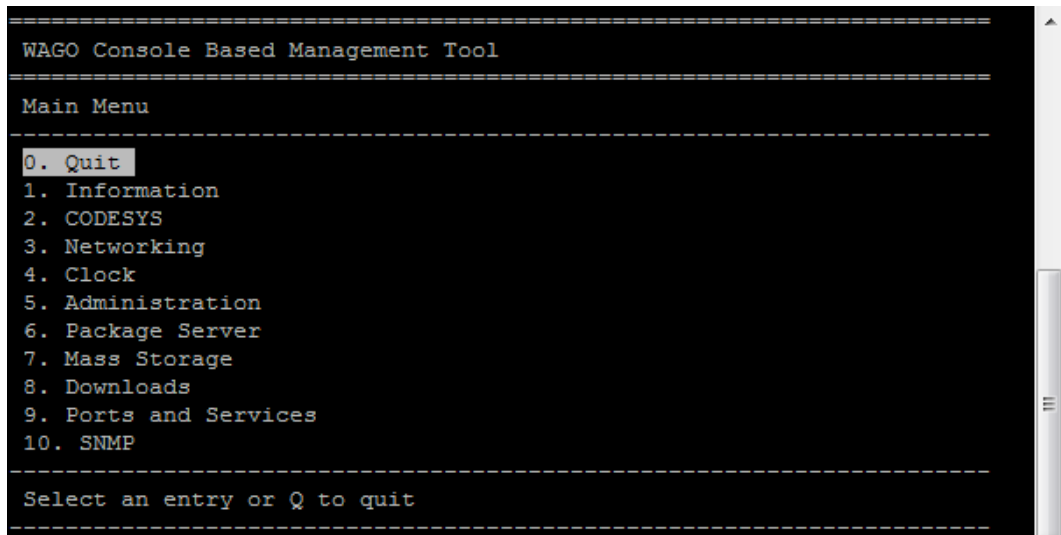
A terminal window showing the WAGO Console Based Management Tool (CBM) main menu. The text is as follows:

```
=====
WAGO Console Based Management Tool
=====
Main Menu
-----
0. Quit
1. Information
2. CODESYS
3. Networking
4. Clock
5. Administration
6. Package Server
7. Mass Storage
8. Downloads
9. Ports and Services
10. SNMP
-----
Select an entry or Q to quit
=====
```

Figure 3: Accessing the CBM using ssh (example)

7.8.3 Configuration using “WAGO ETHERNET Settings”

The “WAGO ETHERNET Settings” program enables you to read system information about your PFC200, make network settings and enable/disable the Web server.

Note



Observe the software version!

To configure the controller, use at least Version 5.4.2.3 dated July 30, 2013 or newer in “WAGO ETHERNET Settings”!

You must select the correct COM port after starting “WAGO ETHERNET Settings”.

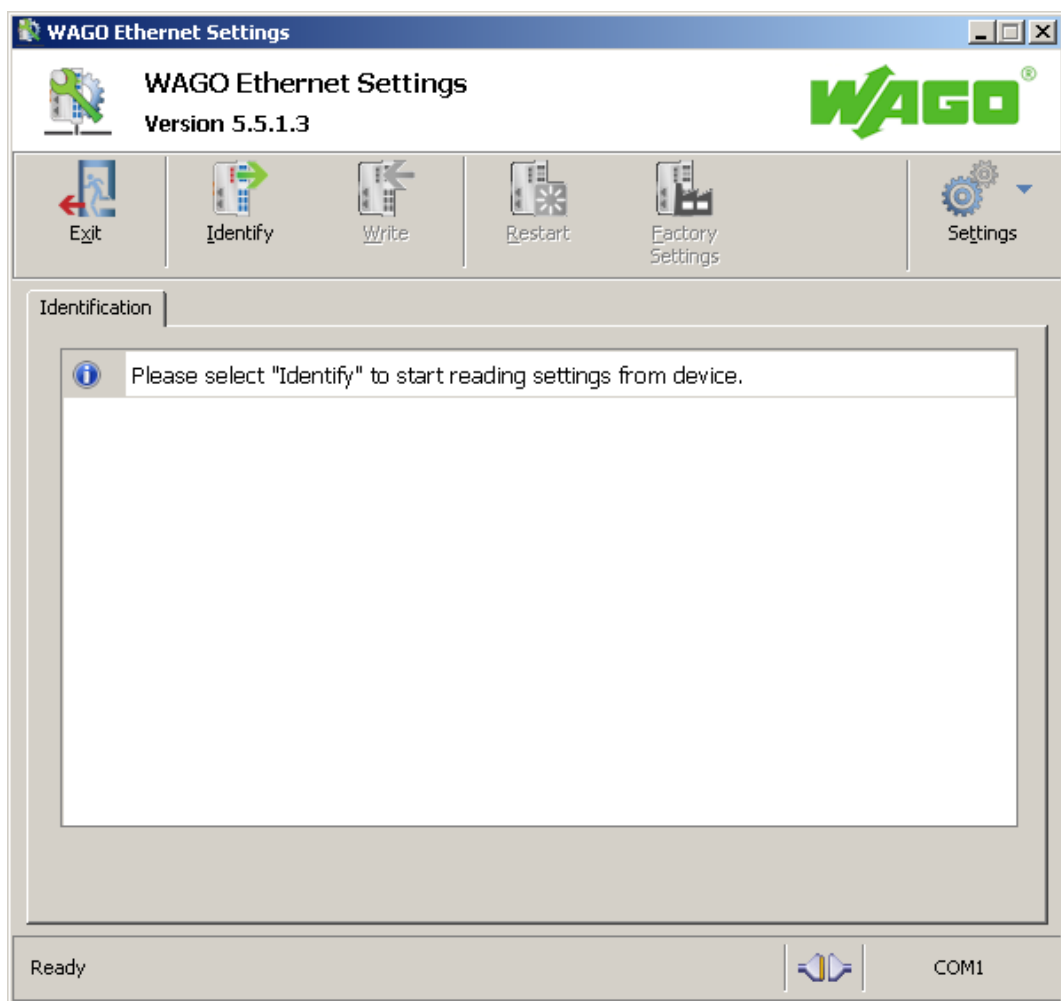

Figure 39: “WAGO ETHERNET Settings” – Start screen

For this, click “Settings” and then “Communication”.

In the “Communication settings” window that then opens, adapt the settings to your needs.

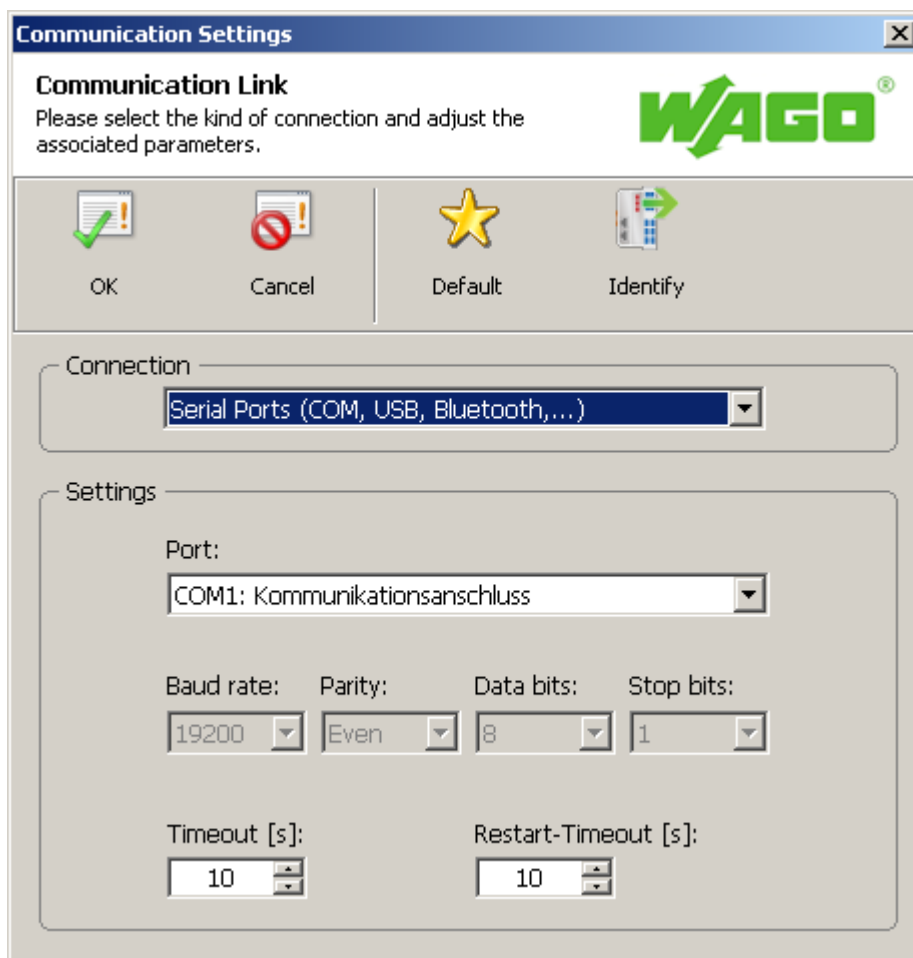

Figure 40: “WAGO ETHERNET Settings” – Communication link

Once you have configured “WAGO ETHERNET Settings” and have clicked **[OK]**, connection to the PFC200 is established automatically.

If “WAGO ETHERNET Settings” has already been started with the correct parameters, you can establish connection to the PFC200 by clicking **[Identify]**.

7.8.3.1 Identification Tab

An overview of the connected device is given here.

Besides some fixed values — e.g., item No., MAC address and firmware version — the currently used IP address and the configuration method are also shown here.

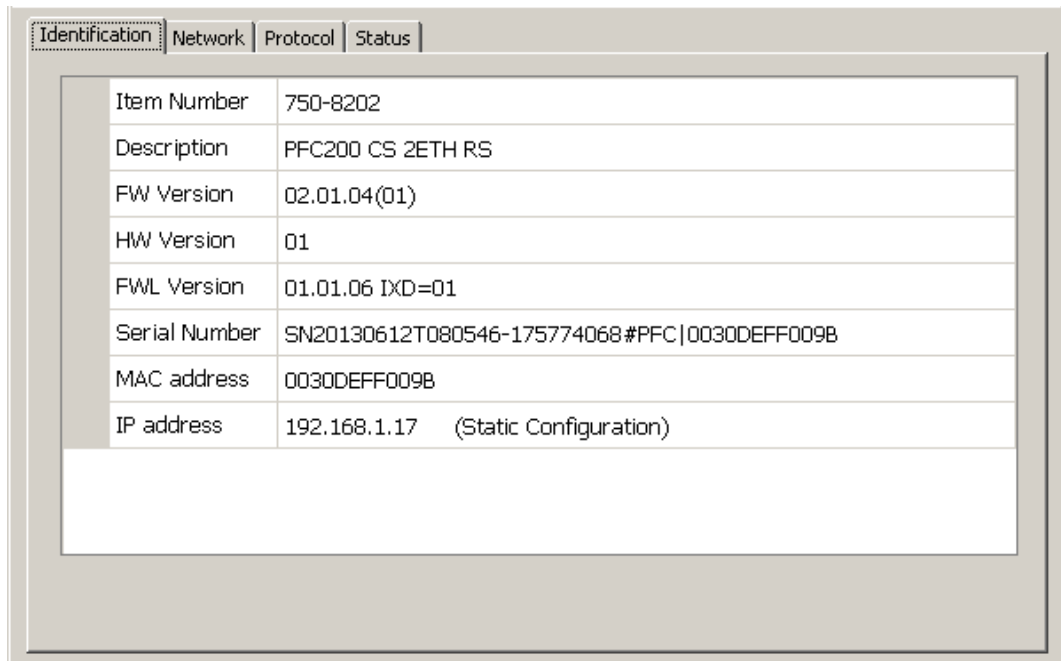

| Item Number | 750-8202 |
|---------------|--|
| Description | PFC200 CS 2ETH RS |
| FW Version | 02.01.04(01) |
| HW Version | 01 |
| FWL Version | 01.01.06 IXD=01 |
| Serial Number | SN20130612T080546-175774068#PFC 0030DEFF009B |
| MAC address | 0030DEFF009B |
| IP address | 192.168.1.17 (Static Configuration) |

Figure 41: “WAGO ETHERNET Settings” – Identification tab (example)

7.8.3.2 Network Tab

This tab is used to configure network settings.

Values can be changed in the “Input” column, while the parameters in use are shown in the “Currently in use” column.

| Parameter | Edit | Currently used |
|------------------------|----------------------|----------------------|
| Address Source | Static Configuration | Static Configuration |
| IP address | 192.168.1.17 | 192.168.1.17 |
| Subnet Mask | 255.255.255.0 | 255.255.255.0 |
| Gateway | 192.168.1.2 | 192.168.1.2 |
| Preferred DNS-Server | 192.168.1.2 | 192.168.1.2 |
| Alternative DNS-Server | 0.0.0.0 | 0.0.0.0 |
| Time Server | 192.168.1.50 | 192.168.1.50 |
| Hostname | | PFC200-FF009B |
| Domain name | | |
| DIP-Switch IP address | DST not supported! | DST not supported! |

Figure 42: “WAGO ETHERNET Settings” – Network tab

Source

Specify how the PFC200 will determine its IP address: Static, via DHCP or via BootP.

IP address, subnet mask, gateway

Specify the specific network parameters for static configuration.

Preferred DNS server, alternative DNS server

Enter the IP address (when required) for an accessible DNS server when identifying network names.

Time server

Specify the IP address for a time server if setting the PFC200's system time via NTP.

Host name

The host name of the PFC200 is displayed here. In the controller's initial state, this name is composed of the string “PFC200” and the last three bytes of the MAC address.

This standard value is also used whenever the chosen name in the “Input” column is deleted.

Domain name

The current domain name is displayed here. This setting can be automatically overwritten with dynamic configurations, e.g., DHCP.

7.8.3.3 Protocol Tab

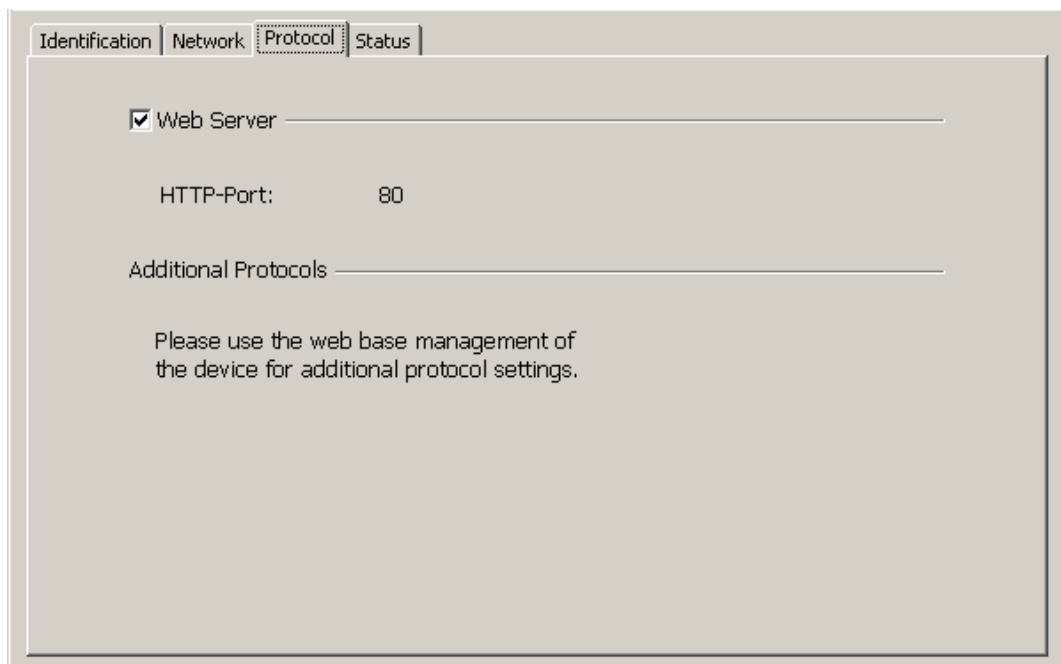

Figure 43: “WAGO ETHERNET Settings” – Protocol tab

You can enable or disable the Web server.

7.8.3.4 Status Tab

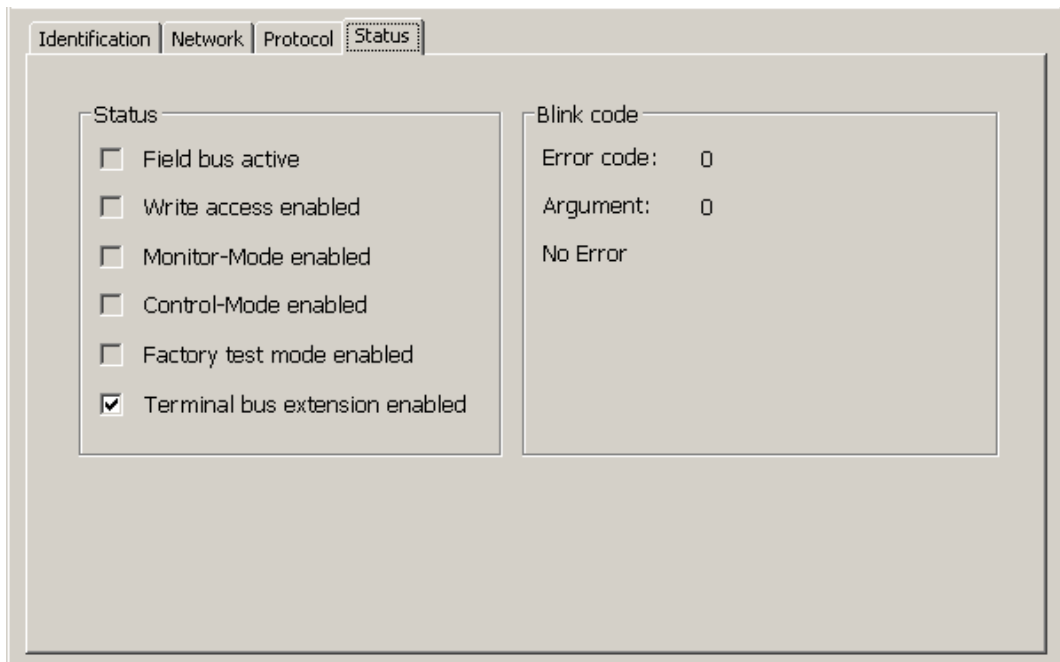

Figure 44: “WAGO ETHERNET Settings” – Status tab

General information about the device status is displayed here.

The **Bus extension** check box has no function for the PFC200, i.e., the bus extension is always active.

8 Run-time System CODESYS 2.3

8.1 Installing the CODESYS 2.3 Programming System

The WAGO target files must also be included for the installation of CODESYS. These contain all device-specific information for the WAGO 750/758 product series.

Proceed as described below to install the CODESYS 2.3 programming software on the fieldbus controller.

1. Insert the “WAGO-I/O-PRO” CD into your computer drive.
2. To install the programming system, follow the instructions that appear on your screen. A successful installation is indicated by a CODESYS icon on your desktop.

8.2 First Program with CODESYS 2.3

This section uses an example to explain the relevant steps required for the creation of a CODESYS project. It is intended as a set of quick start instructions and does not address the full functional range of CODESYS 2.3.

Note



Additional information

For a detailed description of the full range of functions, refer to the “Manual for PLC Programming using CODESYS 2.3” manual available on the “WAGO-I/O-PRO” (759-911) CD.

8.2.1 Start the CODESYS Programming System

Start CODESYS by double clicking on the CODESYS pictogram on your desktop using the Start menu in your operating system. To do this, click on the “Start” button and choose **Programs > WAGO Software > CODESYS > CODESYS V2.3**.

8.2.2 Creating a Project and Selecting a Target System

1. In the menu bar click on **File** and select **New**. The “Target system settings” window then opens. Here, all available target systems that can be programmed with CODESYS 2.3 are listed.
2. Open the selection box in the “Target system settings” window and select the fieldbus controller you are using. In the example shown here this is the PFC200 CS 2ETH RS “WAGO_750-8202”.

3. Click on **[OK]**. The “Target system settings” configuration window then opens.

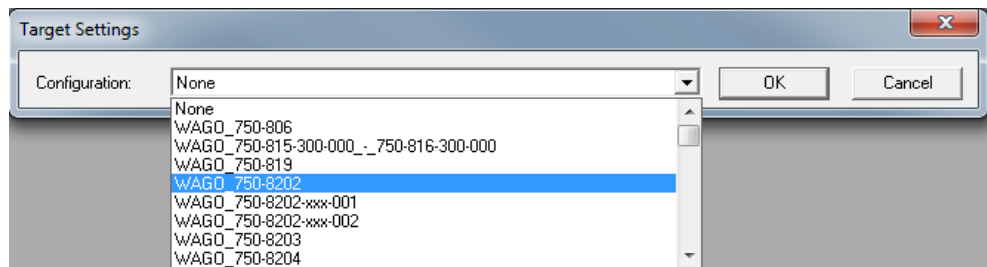

Figure 45: Target system settings (1)

4. To accept the default configuration for the fieldbus controller click **[OK]**. The “New component” window opens.

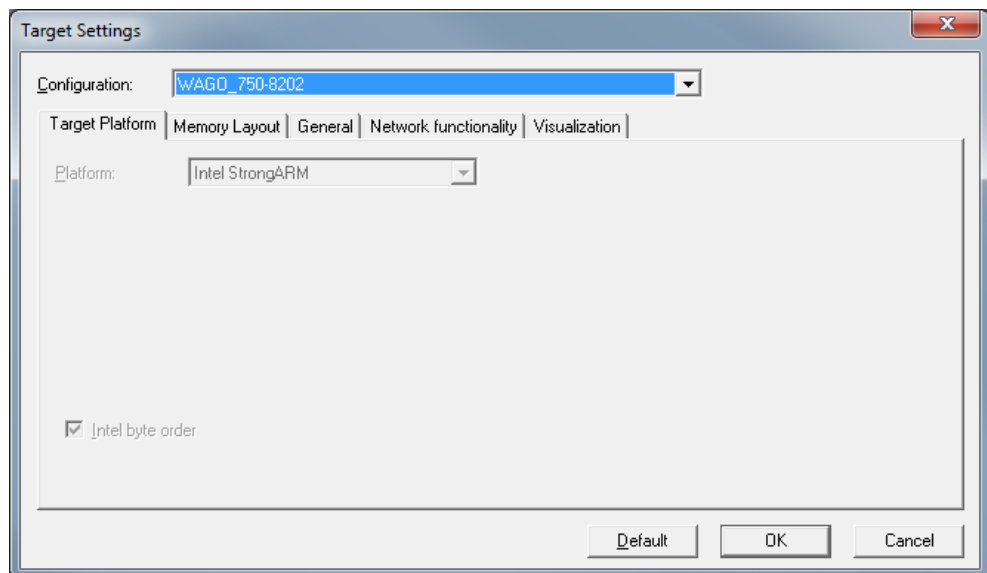

Figure 46: Target system settings (2)

5. In this “New component” window create a new program function block. In the example shown here, the new function block “PLC_PRG” is created in the “ST” programming language.
6. Click on [OK] to create the project. The programming interface opens.

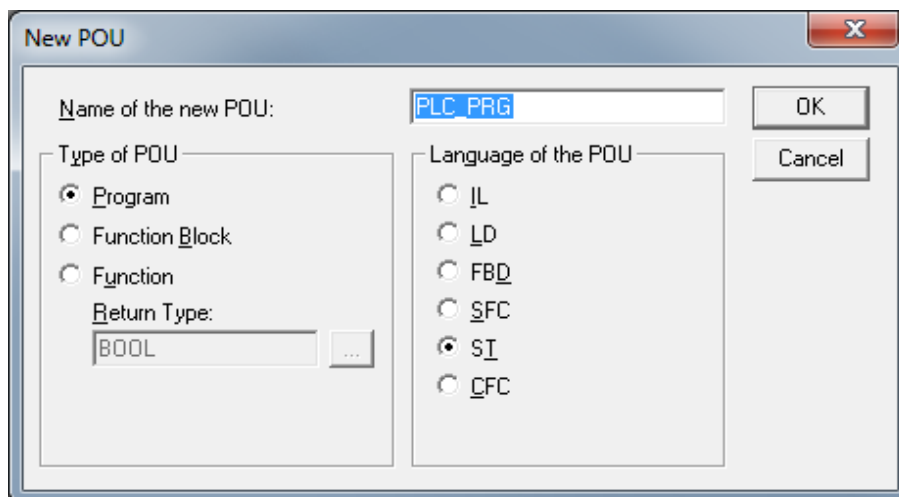

Figure 47: Creating a new function block

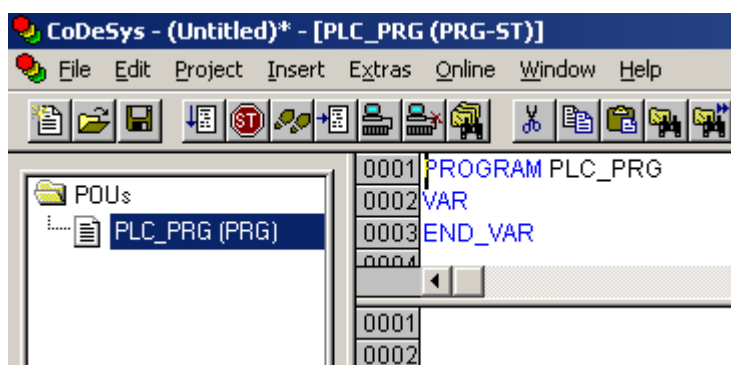

Figure 48: Programming interface with the PLC_PRG program module

8.2.3 Creating the PLC Configuration

Note



Procedure for Creating the PLC Configuration

The procedure explained in this section describes the PLC configuration for the I/O modules connected to the controller.

Information about the controller function for any fieldbuses connected to the system is given in the section on the specific fieldbus.

The PLC configuration is used to configure the fieldbus controller, along with the connected I/O modules and to declare variables for accessing the inputs and outputs of the I/O modules.

1. Click on the “Resources” tab.

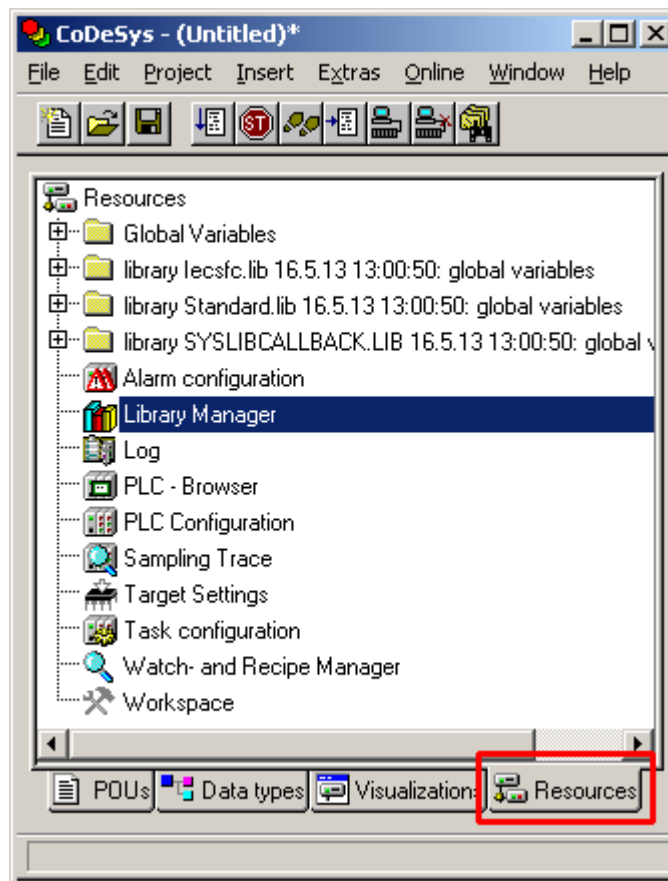

Figure 49: "Resources" tab

2. In the left window double-click on “PLC configuration”. The PLC configuration for the controller opens.
3. Right-click on the entry “K-Bus[FIX]” and then select “Edit” in the contextual menu. The “configuration” dialog window then opens.

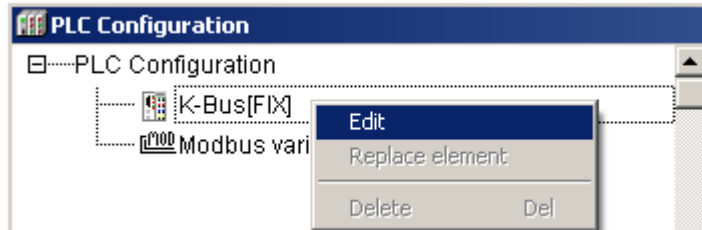

Figure 50: Control configuration – Edit

4. There are three options for accepting the topology for the I/O modules connected to the fieldbus controller. The simplest way is to scan in the topology using *WAGO-I/O-CHECK*. To do this, click on the “Start *WAGO-I/O-CHECK* and scan” button.

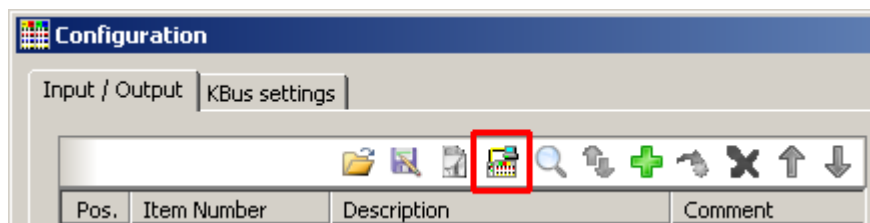

Figure 51: “Start *WAGO-I/O-CHECK* and scan” button

Note



Ensure proper installation of *WAGO-I/O-CHECK*!

This function requires that the latest version of *WAGO-I/O-CHECK* be installed and the IP address set under “Online > Communication parameters”, as otherwise communication will not be possible.

5. *WAGO-I/O-CHECK* is started.

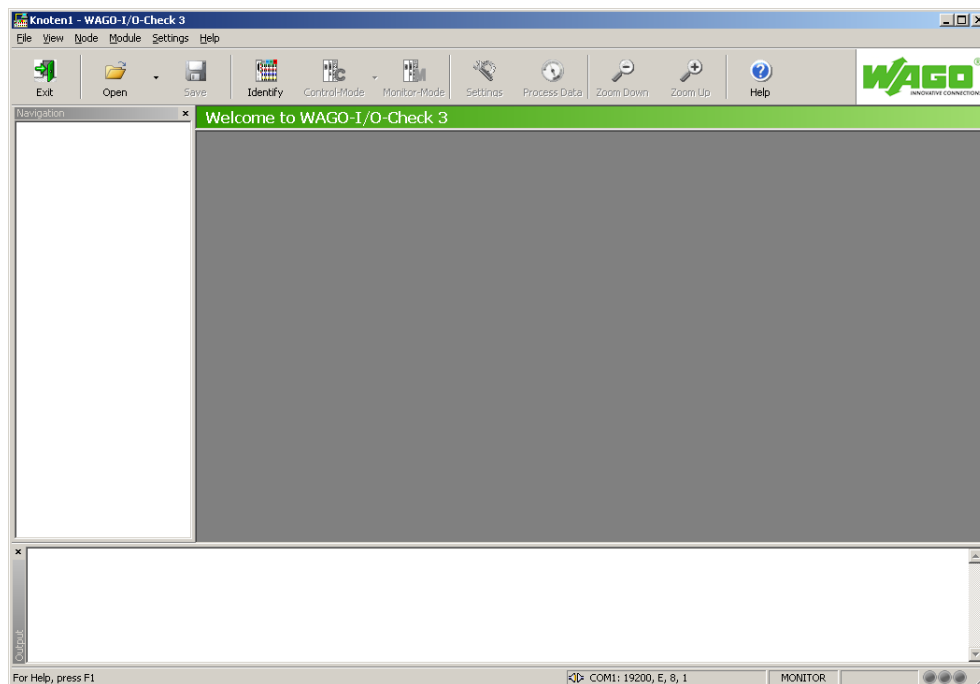

Figure 52: WAGO-I/O-CHECK – Starting screen

6. To connect to the controller and read in the module configuration, click **[Identify]**.
7. If this action is successful click **[Save]** and exit WAGO-I/O-CHECK.
8. The detected I/O modules then appear in the configuration window.

Note



Passive I/O Modules

Remember that passive I/O modules, such as a power supply module (750-602) or end module (750-600) will not be shown in the I/O configurator.

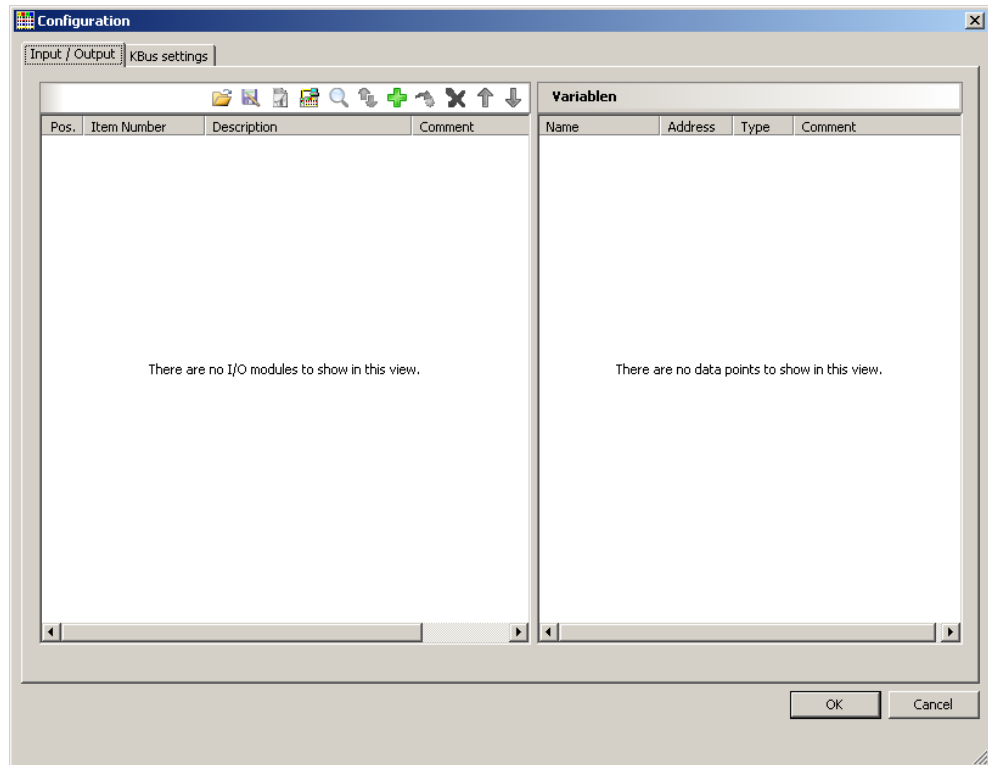

Figure 53: I/O Configurator empty

9. You can use the **[Add]** button to add new I/O modules to manually define or change the configuration.



Figure 54: "Add I/O modules" button

10. You can select a module in the new "Module selection" window that then appears.

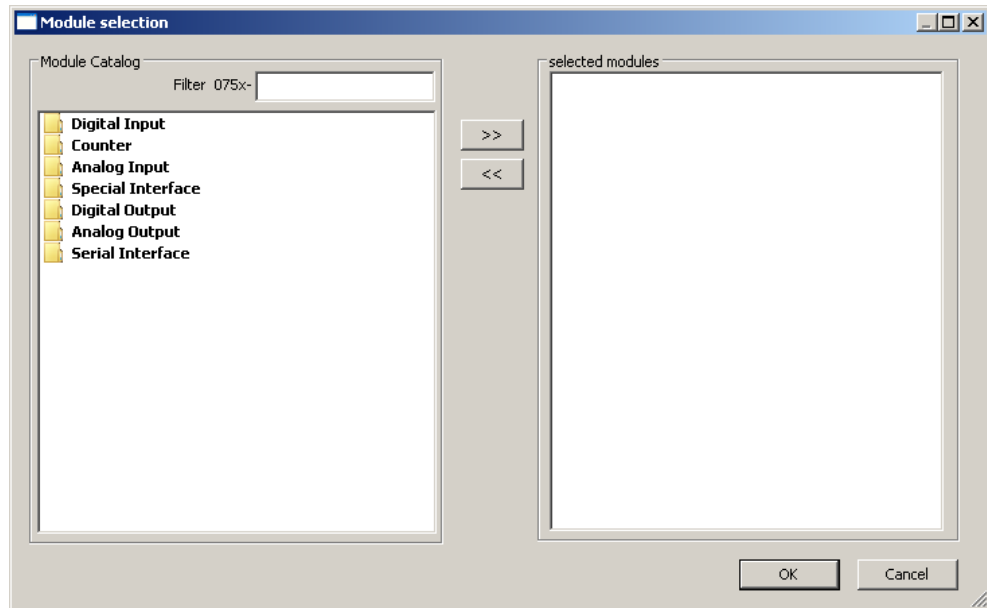

Figure 55: "Module selection" window

11. You can change the position of an I/O module by marking it and then using the arrow buttons at the right edge of the window to move it up or down.

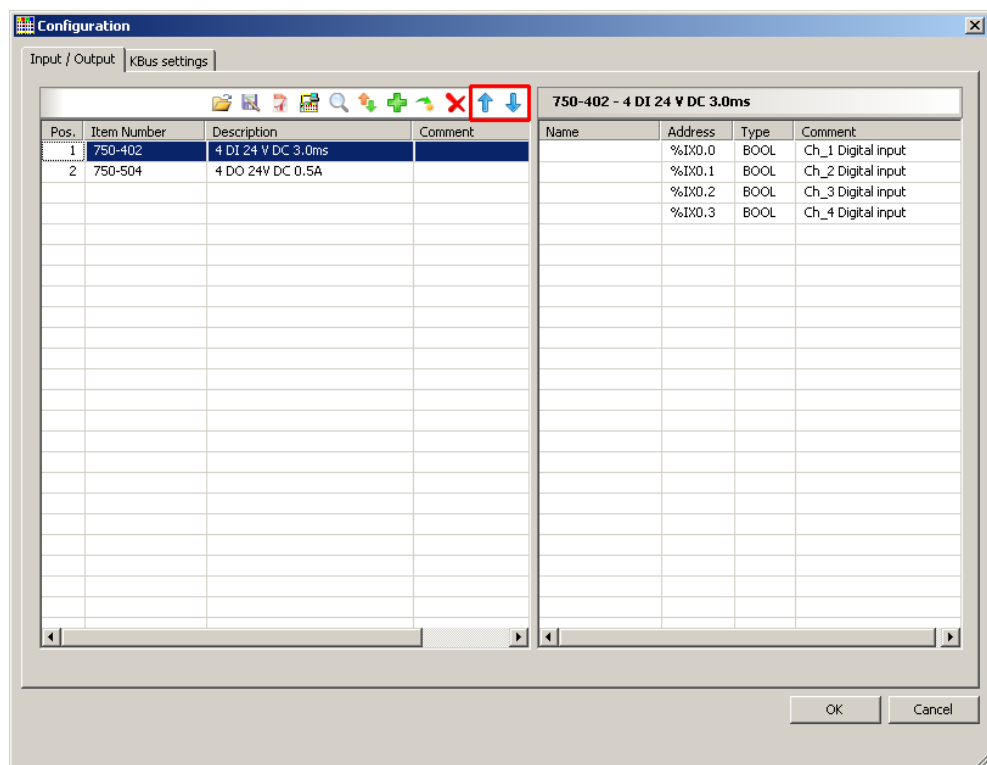

Figure 56: I/O Configurator with defined I/O modules

12. Use **[Import configuration from file]** to add a configuration imported previously using *WAGO-I/O-CHECK*.
13. To close the I/O Configurator, click **[OK]**.

14. The individual inputs and outputs of the selected I/O module are displayed in the right half of the configuration window.
Here, you can declare a dedicated variable in the “Name” column for each input and output, e.g., “Output_1”, “Output_2”, “Input_1”, “Input_2”.

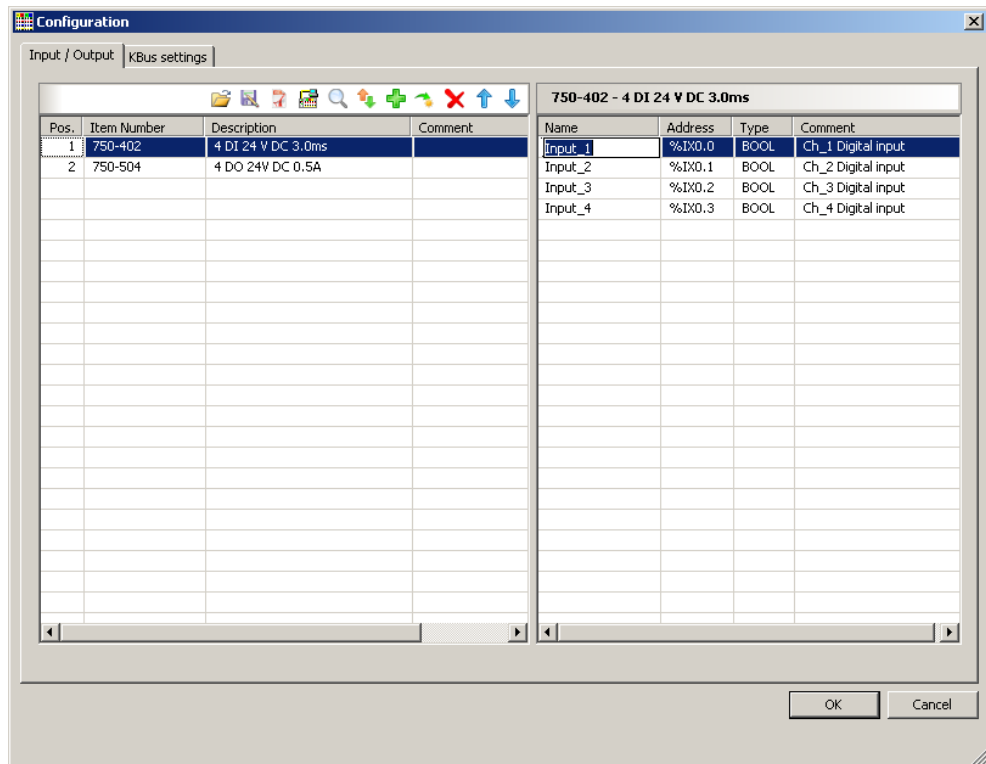

Figure 57: Variable declaration

15. The added I/O modules appear in the control configuration under “K-Bus[FIX]” with their associated fixed addresses and, where applicable, their previously set variable name.

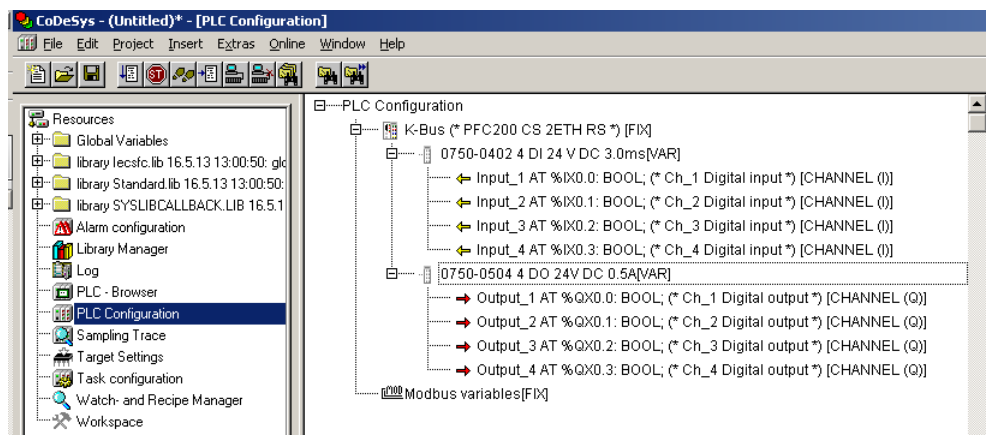

Figure 58: Control configuration: I/O modules with their associated addresses

8.2.4 Editing the Program Function Block

To edit the PLC_PRG program function block, go to the “Function block” tab and double-click on the PLC_PRG program module.

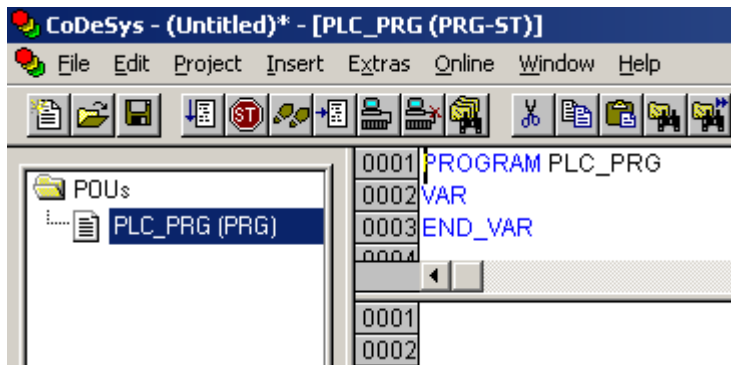

Figure 59: Program function block

The following example illustrates the editing of the program function block. To do this, an input is assigned to an output:

1. Press **[F2]** to open the Input assistant, or right click and select “Input assistant” from the contextual menu.

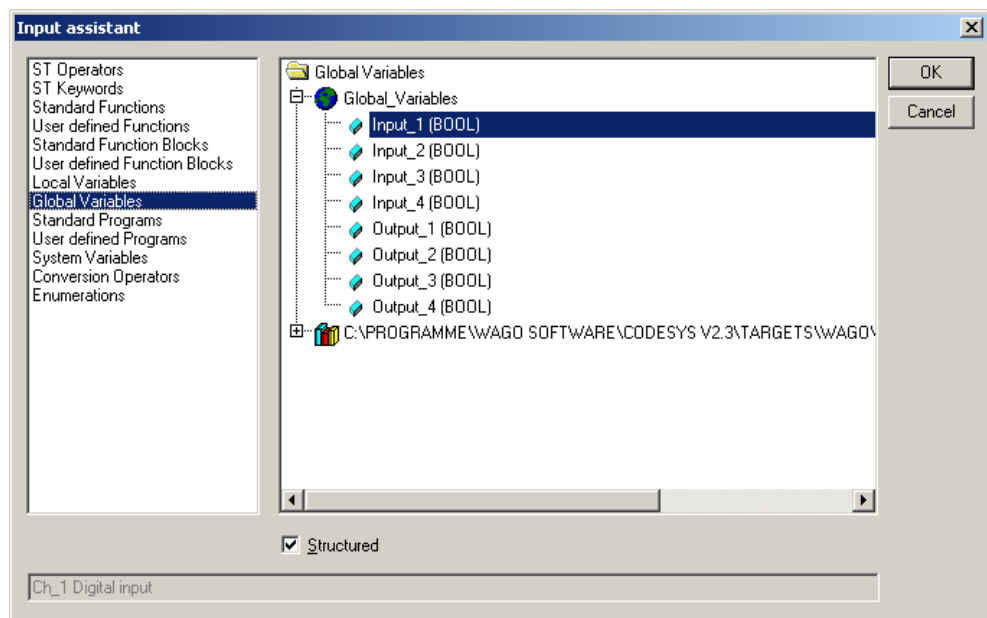

Figure 60: Input assistant for selecting variables

2. Under “Global variables” select the previously declared variable “Output_1” and click **[OK]** to add it.
3. Enter the allocation “=” behind the variable name.
4. Repeat Step 2 for the “Input_1” variable.

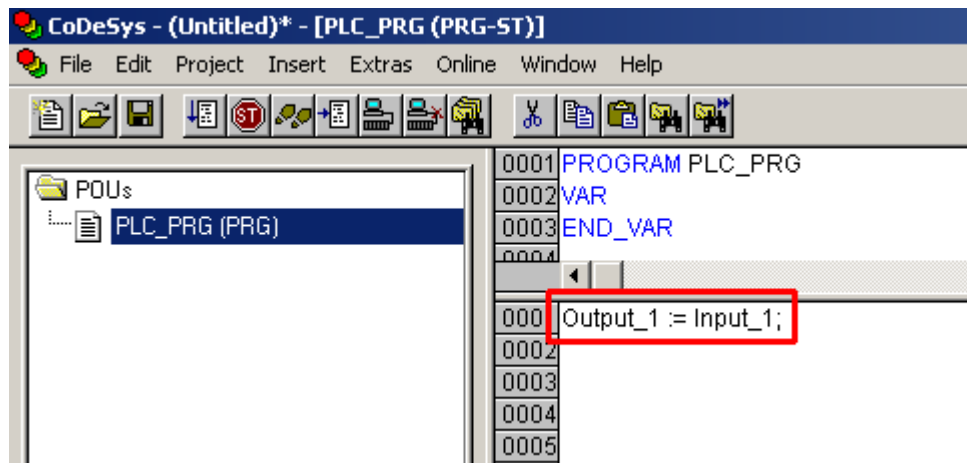

Figure 61: Example of an allocation

5. To compile, click on **Project > Compile all** in the menu bar.

8.2.5 Loading and Running the PLC Program in the Fieldbus Controller (ETHERNET)

Requirement:

- The simulation is deactivated (**Online > Simulation**).
- The PC is linked to the controller via ETHERNET. Refer to Section “Device Description” > ...> “ETHERNET – X1, X2 Network Connection”.

Proceed as follows:

1. In the menu bar click on **Online** and select **Communication parameters** The "Communication Parameters" window opens.
2. To select a communication link click on [**New ...**] in the “Communication Parameters” window. A window opens in which you can define a communication link.

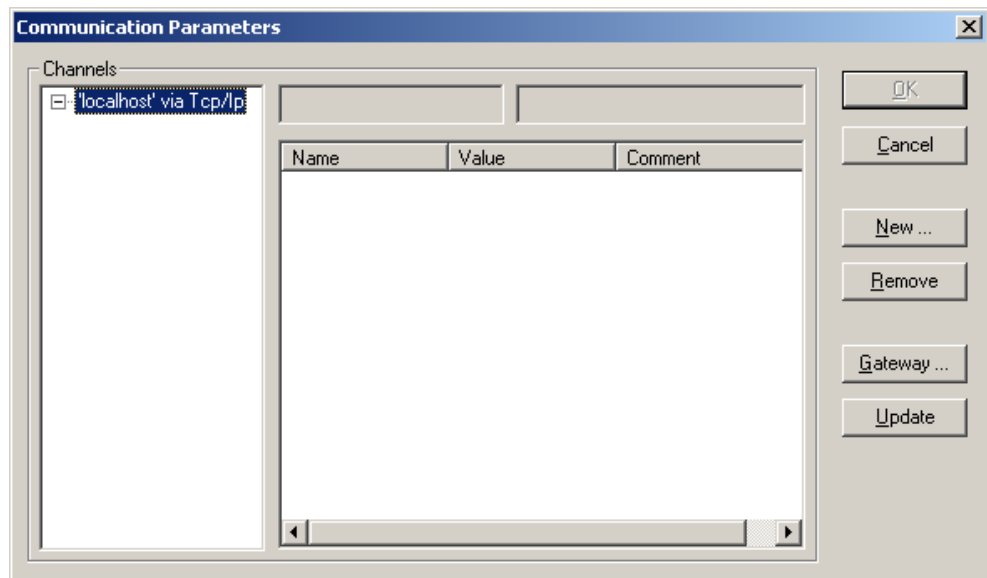

Figure 62: Creating a communication link – Step 1

3. In the “Name” field enter a designation for your fieldbus controller and then click on “Tcp/Ip (Level 2 Route)”. Then click [**OK**].

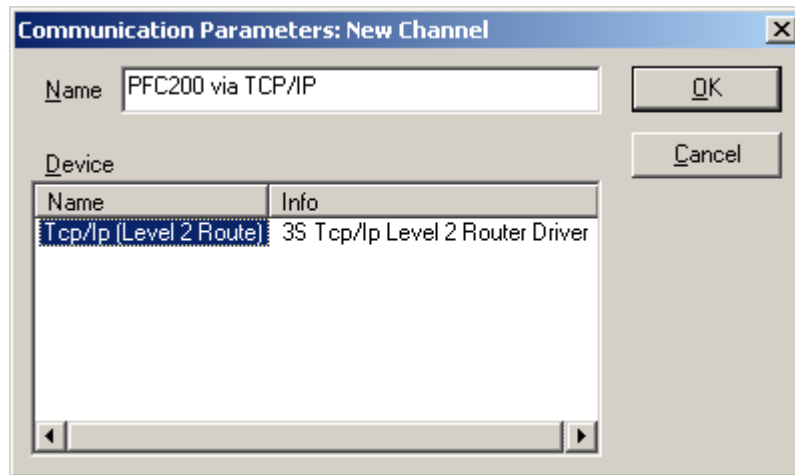

Figure 63: Creating a communication link – Step 2

4. In the “Communication Parameters” window enter the **IP address of your fieldbus controller** in the “Address” field and then press Enter. To close the window click on **[OK]**.
Zum Auswählen eines bereits angelegten Feldbuscontrollers selektieren Sie diesen im linken Fenster, und klicken Sie anschließend auf **[OK]**.

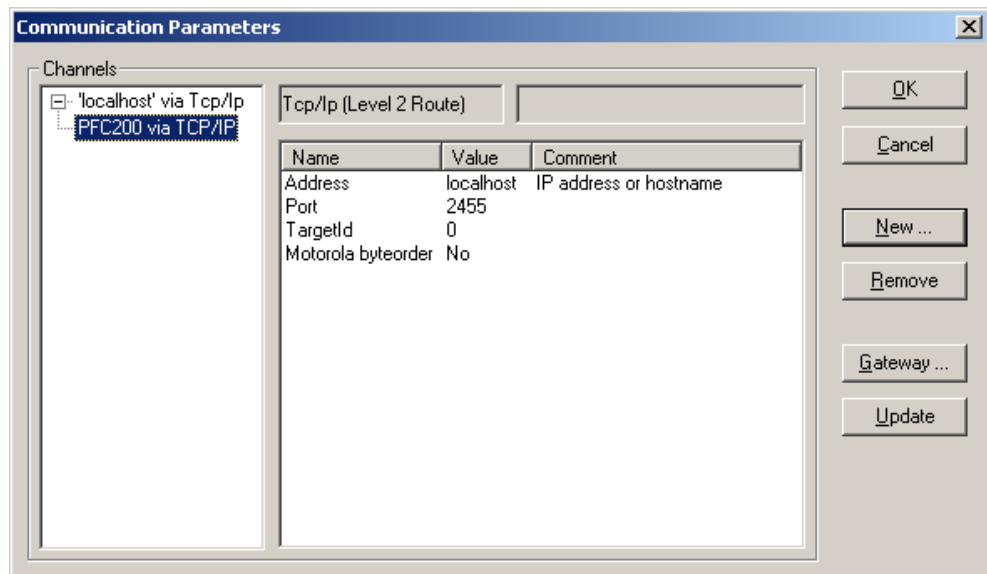

Figure 64: Creating a communication link – Step 3

5. Transfer the PLC program by clicking on **Online** in the menu bar and select **Login**.
6. Ensure that the Run/Stop switch for the fieldbus controller is set to “Run”.
7. Start the PLC program by clicking on **Online > Start** in the menu bar.

8.2.6 Creating a Boot Project

Create a boot project to ensure that the PLC program starts automatically again after a fieldbus controller restart. In the menu bar select **Online > Create boot project**. You must be logged in to CODESYS to use this function.

Note



Automatic loading of the boot project

In addition, you can load the boot project automatically when starting the fieldbus controller. Click on the “Resources” tab and open “Target system settings”. Select the “General” tab and “Load boot project automatically”.

If a boot project (DEFAULT.PRG and DEFAULT.CHK) is present under */home/codesys* and the “Run/Stop” switch of the fieldbus controller is set to “Run”, the fieldbus controller automatically starts with the processing of the PLC program. The PLC program is not started if the switch is set to “Stop”.

If a PLC program is running in the fieldbus controller, a PLC task starts with the reading of the fieldbus data (only with fieldbus controllers and fieldbus connection), the integrated input and output data and the I/O modules. The output data changed in the PLC program is updated after the PLC task is processed. A change in operating mode (“Stop/Run”) is only carried out at the end of a PLC task. The cycle time includes the time from the start of the PLC program to the next start. If a larger loop is programmed within a PLC program, the task time is prolonged accordingly. The inputs and outputs are updated during processing. These updates only take place at the end of a PLC task.

8.3 Syntax of Logical Addresses

Access to individual memory elements according to IEC 61131-3 is possible using only the following special symbols:

Table 82: Syntax of logical addresses

| Item | Prefix | Description | Notes: |
|------|--------|-----------------------------|------------|
| 1 | % | Starts the absolute address | - |
| 2 | I | Input | |
| | Q | Output | |
| 3 | M | Flag | Data width |
| | X | Single bit | |
| | B- | Byte (8 bits) | |
| | W | Word (16 bits) | |
| 4 | D | Double word (32 bits) | |
| | | Address | |

Two examples:

Addressing by word

%QW27 (28th word)

Addressing by bit

%IX1.9 (10th bit in word 2)

Enter the character string of the absolute address without empty spaces. The first bit of a word has an address of 0.

8.4 Creating Tasks

Set the time response and the priority of individual tasks in the task configuration.

Note



Watchdog

In an application program without task configuration, there is no watchdog that monitors the cycle time of the application program (PLC_PRG).

Create a task as follows:

1. Open the task configuration by double-clicking on the “Task configuration” module in the “Resources” tab.

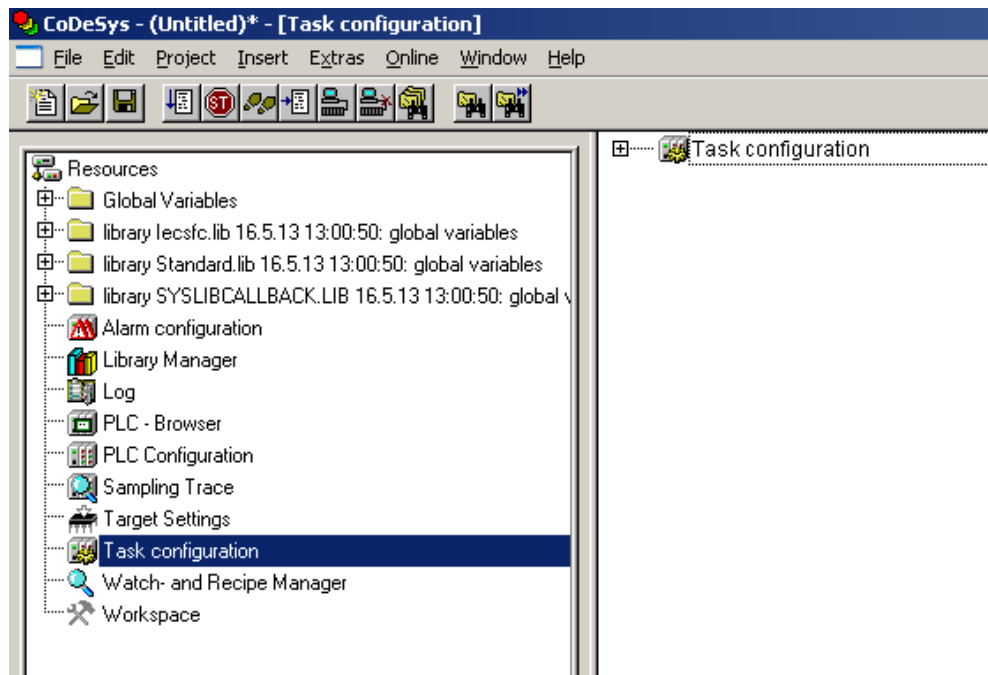

Figure 65: Task configuration

2. To create a task right-click on “Task configuration” and in the contextual menu select “Attach task”.

- To assign a new name to the task (e.g. PLC_Prog), click on “New Task”. Then select the type of task. In this example, this is the “cyclic” type.

Note



Observe the cycle time!

The minimum cycle time for I/O-based tasks is 2 milliseconds (ms)!

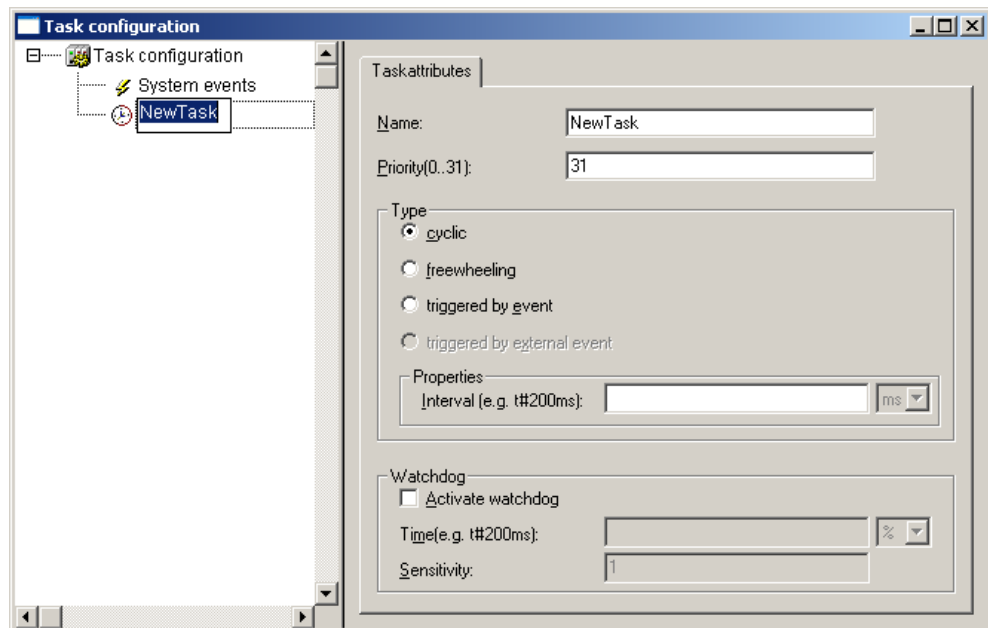

Figure 66: Changing task names 1

- Add the program module PLC_PRG that you have just created (see Section “Editing the Program Modules”). To do this, right-click on the “Clock” symbol and in the contextual menu select “Attach program call-up”. Then, click the [...] button and [OK].

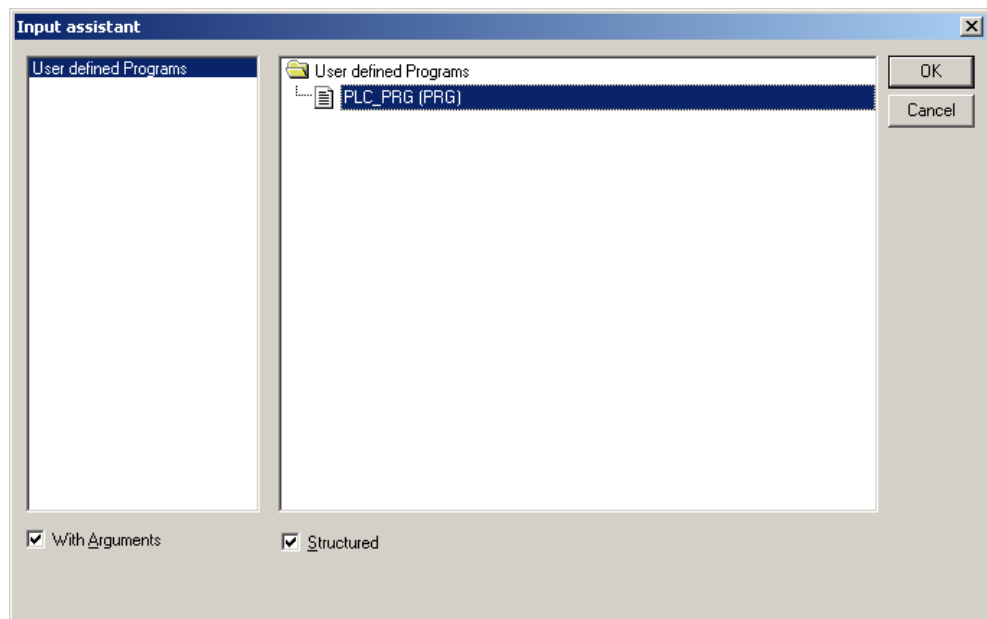

Figure 67: Call-up to add to the program module

5. Compile the example program by selecting **Project > Rebuild all** in the context menu.

8.4.1 Cyclic Tasks

You can assign a priority for each task in order to establish the task processing sequence.

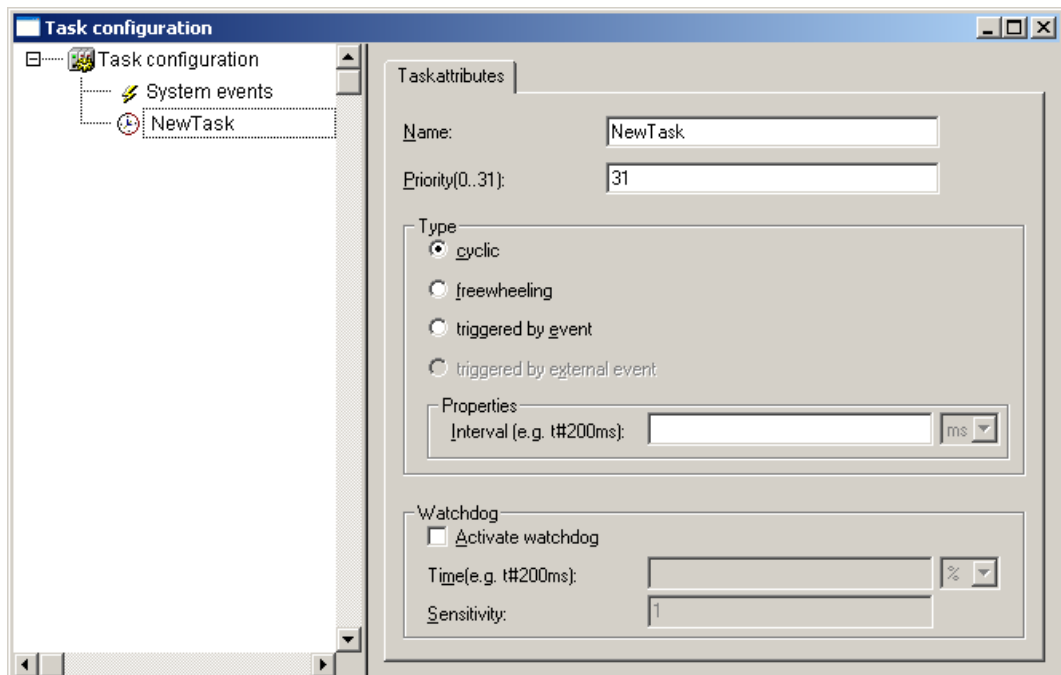

Figure 68: Cyclic task

Note



Order of Task Processing

The priorities given below do not specify the order of task processing. The tasks start in an arbitrary order.

Priority 0 ... 5:

Important arithmetic operations and synchronized access to I/O module process images are to be carried out as tasks with the highest priorities 0 ... 5. These tasks are processed fully according to priority and correspond to Linux[®] RT priorities -79 through -74.

Priority 6 ... 20:

Real-time access, such as access to ETHERNET and the file system, to fieldbus data and to the RS-232 interface (when available) are to be carried out as tasks with average priorities 6 ... 20. These tasks are processed fully according to priority and correspond to Linux[®] RT priorities -40 through -26.

Priority 21 ... 31:

Applications such as long-lasting arithmetic operations and non-real-time-relevant access to ETHERNET and the file system, to fieldbus data and the RS-232 interface (when provided) are to be carried out as tasks with the lowest priorities 21 ... 31. No priority distinction is made between tasks of priorities 21 ... 31.

These tasks all receive the same computing time from the operating system (“Completely Fair Scheduler” procedure).

8.4.2 Freewheeling Tasks

So-called freewheeling tasks are not processed in cycles. Their processing depends solely on the current capacity of the system. The input field “Priority (0 ... 31)” is provided for freewheeling tasks without a function. These tasks are handled as tasks with priority 21 ... 31.

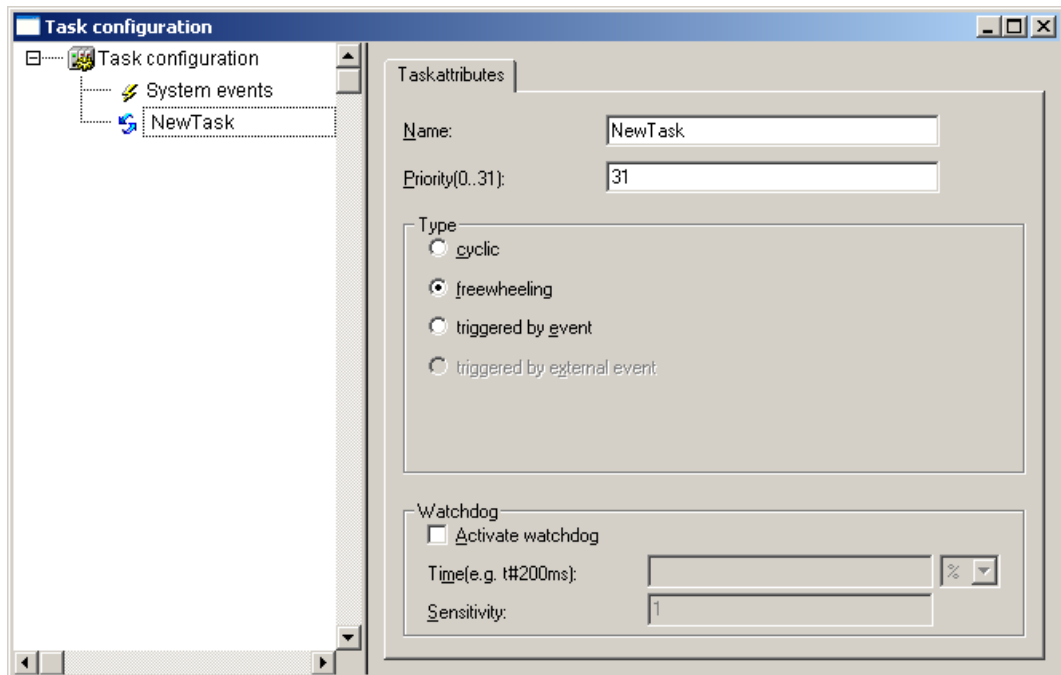

Figure 69: Freewheeling task

Note



PLC-PRG as Freewheeling Task without Task Configuration

If you do not perform any task configuration, the program PLC_PRG is carried out with the lowest priority at an interval of 10 ms. The runtime of "freewheeling tasks" is not monitored by a CODESYS watchdog.

8.5 System Events

Event tasks can be used in the CODESYS task configuration in addition to cyclical tasks. Event tasks call up certain events in the device.

To activate events and define a program to be called up, open the window “Task configuration” in the “Resources” tab in the CODESYS development environment.

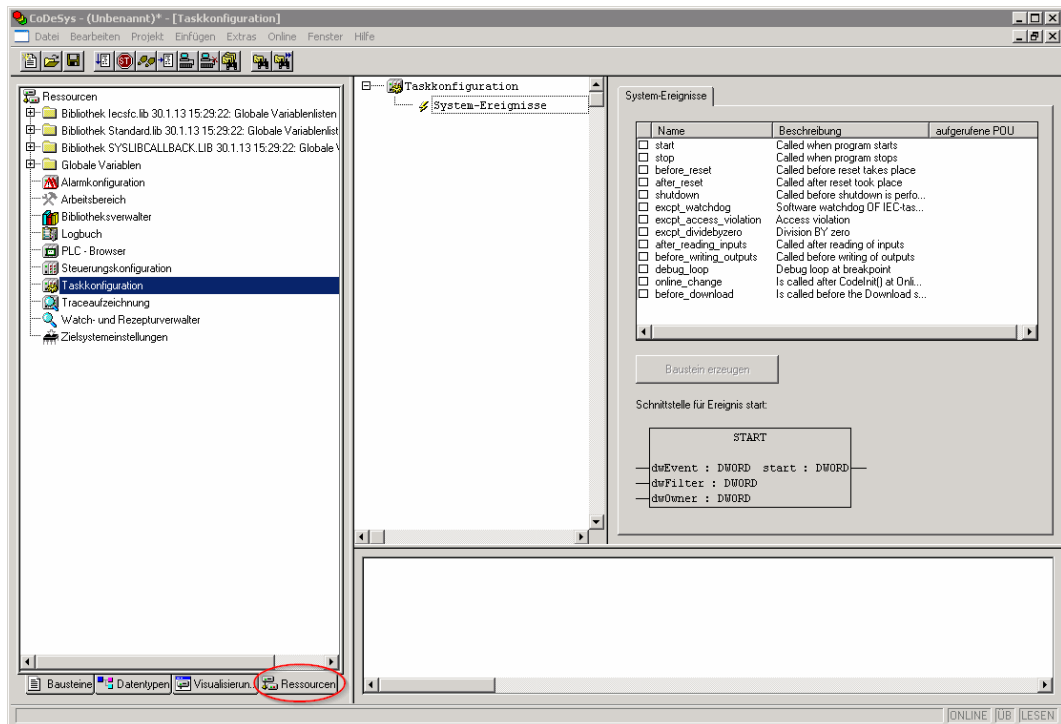

Figure 70: CODESYS – System events

Note



Do not set debug points in the event handlers!

Debug points in event handlers can lead to unforeseeable errors and must therefore not be set!

The following events can be activated:

Table 83: Events

| Name | Description |
|------------------------|---|
| start | The event is called directly after the user program starts. |
| stop | The event is called directly after the user program stops. |
| before_reset | The event is called directly before the user program is reset. |
| after_reset | The event is called directly after the user program is reset. |
| shutdown | The event is called directly before the user program is shutdown. |
| excpt_watchdog | The event is called if a task watchdog is recognized. |
| excpt_access_violation | The event is called if a memory access error to an invalid memory area is recognized. (incorrect pointer, invalid array index, invalid data descriptor) |
| excpt_dividebyzero | The event is called if a division by zero is recognized. |
| after_reading_inputs | The event is triggered after reading all of the inputs independent of the user program. |
| before_writing_outputs | The event is triggered before writing all of the outputs independent of the user program. |
| debug_loop | This event is triggered at every task call, if a breakpoint was reached in this task and the processing of this task is therefore blocked. |
| online_change | This event is called up after initialization of the program on an online change. |
| before_download | This event is always called up before a download from the IDE to the device takes place. |

Note



Application stops on a non-defined event handler!

If “excpt” events occur in the system and an event handler has not been defined, the application goes into the "Stop" status.

8.5.1 Creating an Event Handler

The example here is provided to illustrate how to define and use an event handler. The event handler “`excpt_dividebyzero`” is used in this example.

First, a program is generated in the PLC_PRG- module which provokes division by 0.

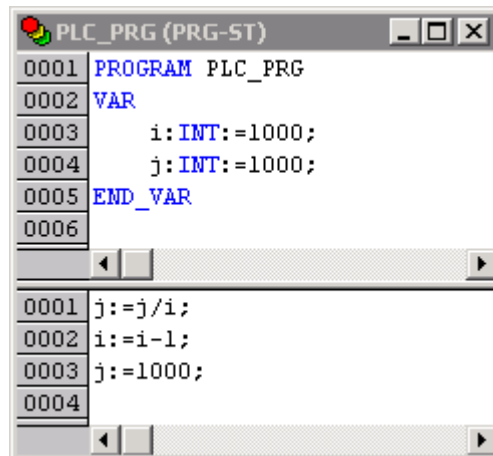

Figure 71: CODESYS program provokes division by “0”

After this, the system event “`excpt_dividebyzero`” is activated in the Task Configurator and the name of the event handler to be generated is entered in the column “Called POU”.

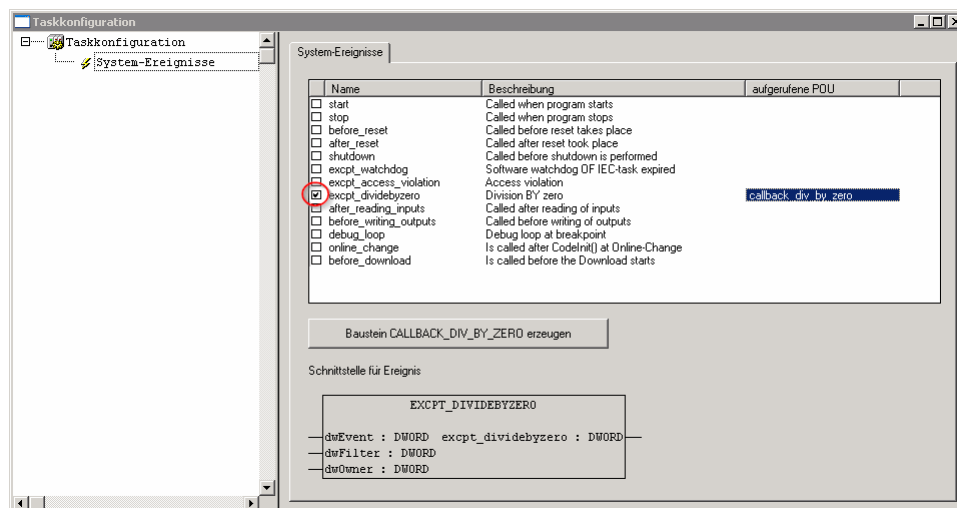

Figure 72: CODESYS – Creating and activating an event handler

To generate the event handler, click [**Generate CALLBACK_DIV_BY_ZERO function block**].

A new function having the defined name then appears in the “Function blocks” tab.

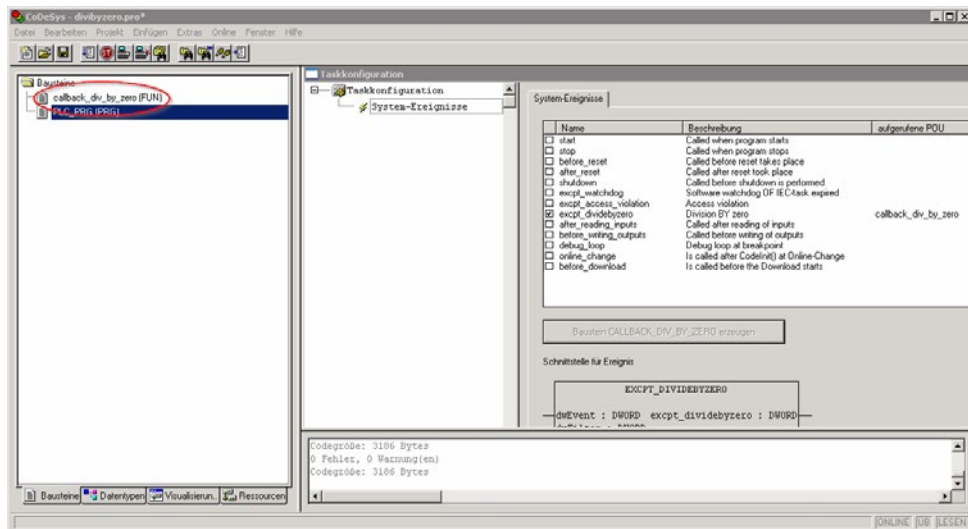

Figure 73: CODESYS – New module has been generated

Handling for the event that has occurred is now programmed in this new function.

In the example here, the event is documented in a global variable.

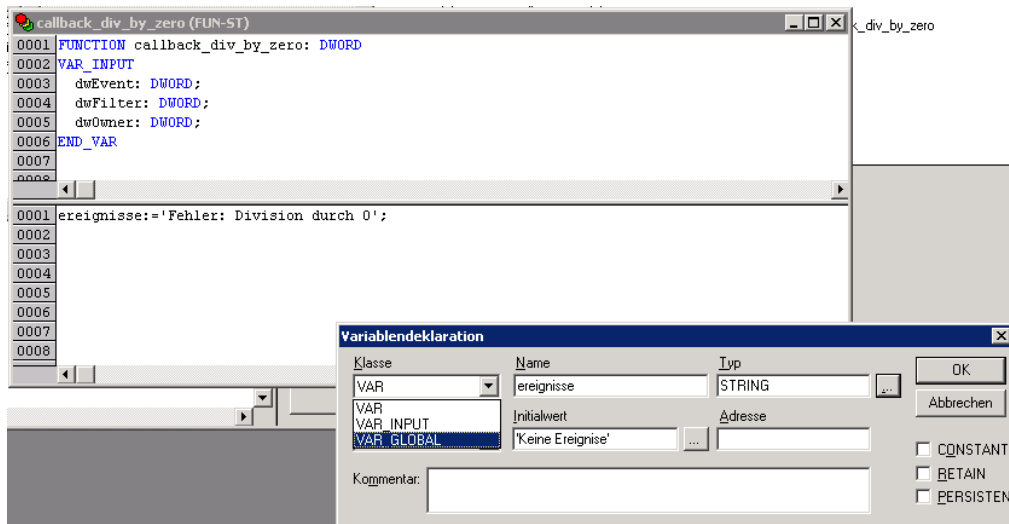

Figure 74: CODESYS – Enter the event in a global variable

The newly created project is now supported and can be loaded to the controller.

After startup, the value of the “Events” variable changes only when counter “i” reaches the value 0, meaning that division by 0 has been performed.

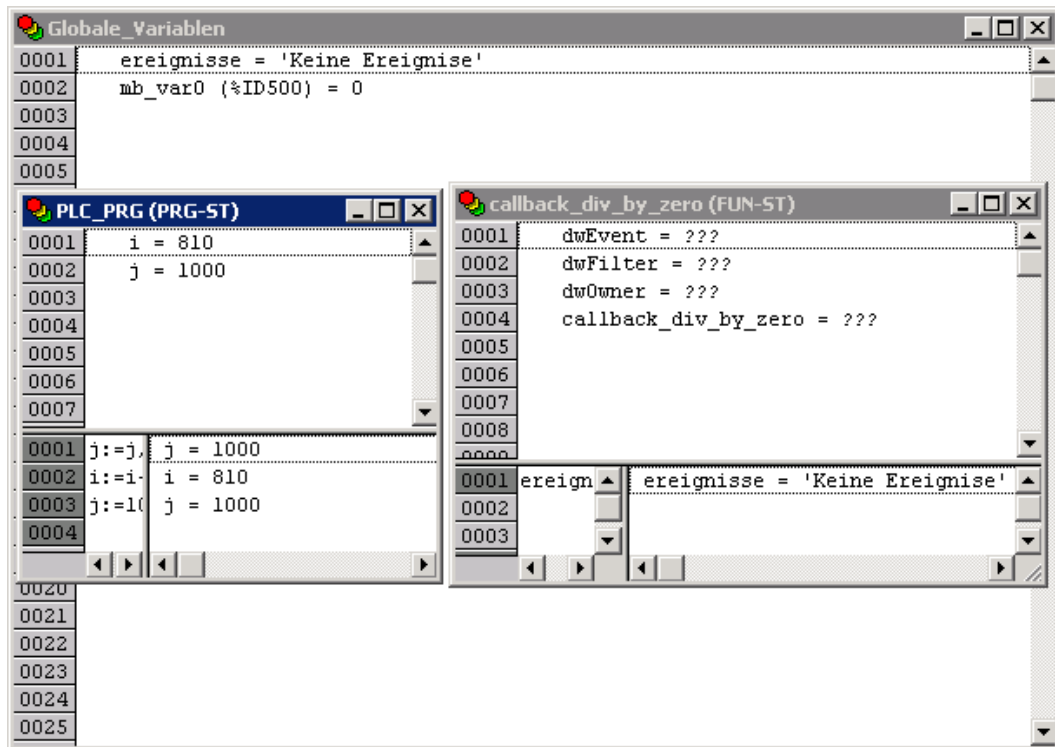

Figure 75: CODESYS – Variable contents prior to division by “0”

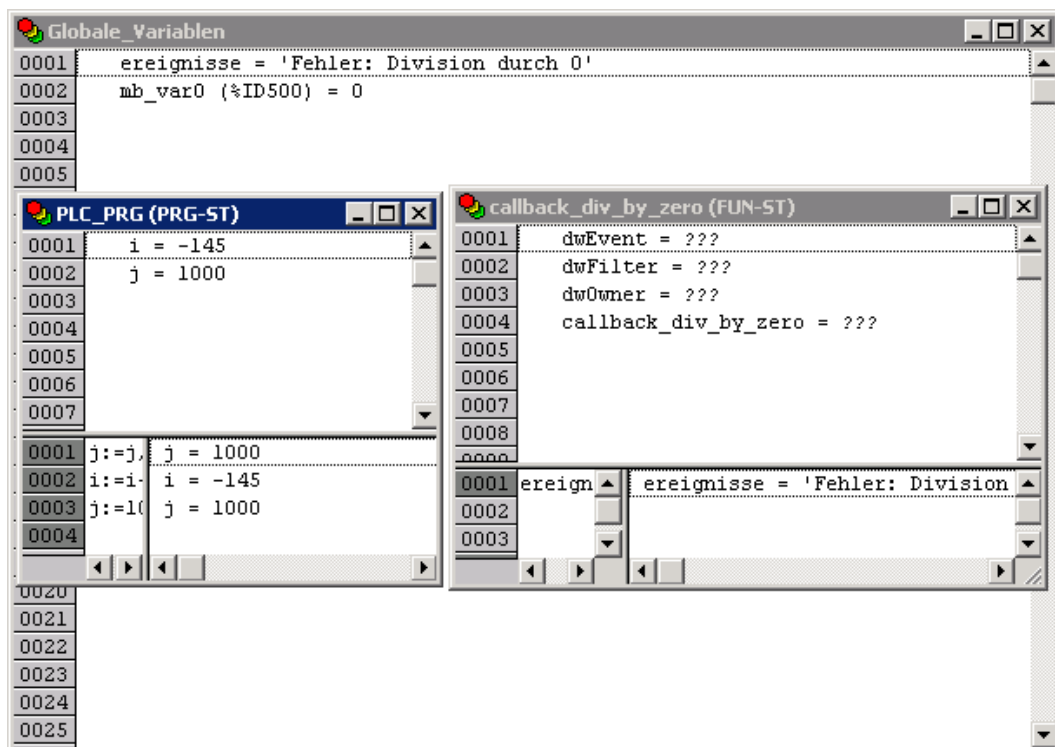

Figure 76: CODESYS – Variable contents after division by “0” and call-up of the event handler

8.6 Process Images

A process image is a memory area in which the process data is stored in a defined sequence and consists of the I/O modules attached to the internal bus, the PFC variables, the bit memory address area and the slaves attached to the fieldbus.

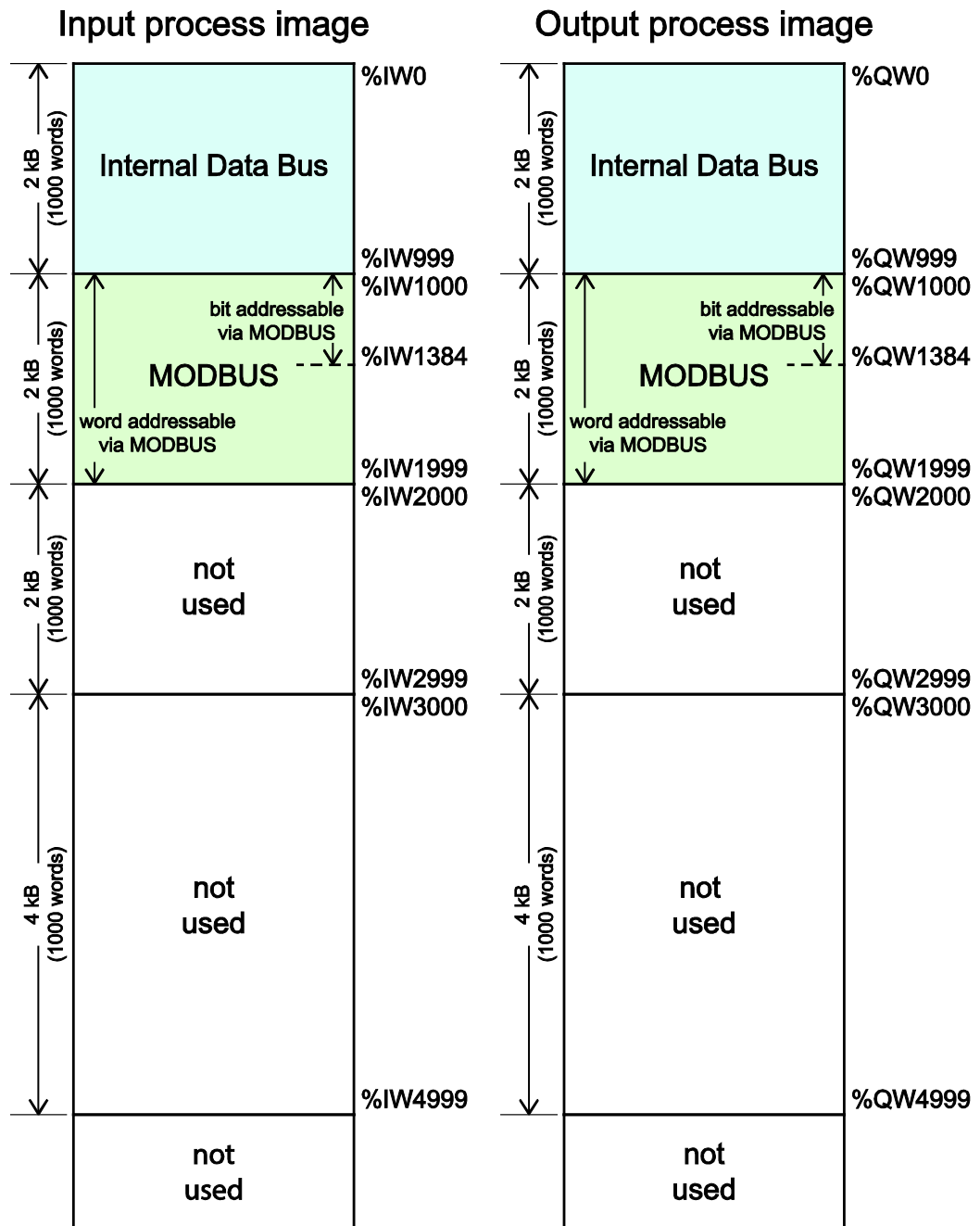

Figure 77: Process image

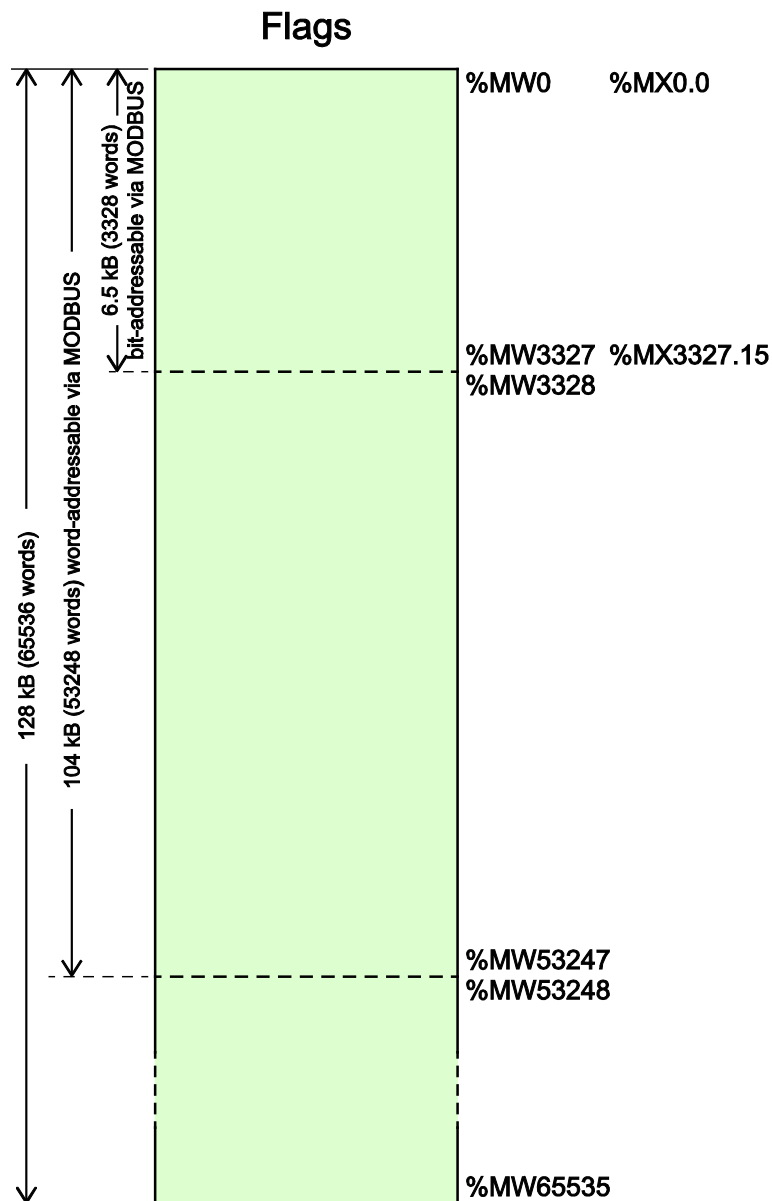

Figure 78: Flag area

8.6.1 Process Images for I/O Modules Connected to the Controller

After starting the fieldbus controller, it automatically detects all connected I/O modules.

The analog input and output data is stored first word by word in the process image. Subsequent to this, come the digital input and output data bits combined to form words.

The size and structure of the process image for the I/O modules connected to the system are described in the appendix.

Note



I/O Module Data Width

The data width of an I/O module is between 0 and 48 bytes.

Note



I/O Module Process Data

Check the I/O module process data whenever you add or remove the modules to/from the fieldbus controller. Changing the I/O module topology results in an adjustment of the process image, as the process data addresses also change.

8.6.2 Process Image for Slaves Connected to the Fieldbus

The size and structure of the process image for the slaves connected to the system are described in the section for the specific fieldbus.

Note



No direct access from fieldbus to the process image for I/O modules!

Any data that is required from the I/O module process image must be explicitly mapped in the CODESYS program to the data in the fieldbus process image and vice versa! Direct access is not possible!

8.7 Access to Process Images of the Input and Output Data via CODESYS 2.3

The following tables describe the possibilities with which you can access the address ranges of the process image for the inputs and outputs connected to the internal data bus.

Table 84: Access to the Process Images of the Input and Output Data – Internal Data Bus

| Memory area | Description | Access via PLC | Logical Address Space |
|--|---|----------------|-------------------------|
| Internal data bus input process image | Map of the local input modules (internal data bus, I/O module 1 to 1 bis 64*) in the RAM. | Read | Word %IW0 to %IW999 |
| | | | Byte %IB0 to %IB1999 |
| Internal data bus output process image | Map of local output modules (internal data bus, I/O module 1 to 64*) in the RAM. | Read/ Write | Word %QW0 to %QW999 |
| | | | Byte %QB0 to %QB1999 |

* The use of up to 250 I/O modules is possible with the WAGO internal data bus extension modules.

Table 85: Access to the Process Images of the Input and Output Data – MODBUS

| Memory area | Description | Access via PLC | Logical Address Space |
|-----------------------------|---|----------------|--|
| MODBUS input process image | MODBUS input variables, addressed by word via MODBUS | Read | Word %IW1000 to %IW1999 |
| | | | Byte %IB2000 to %IB3999 |
| | MODBUS input variables, addressed by bit via MODBUS | Read | Bit %IX1000.0 ... %IX1000.15 to %IX1384.0 ... %IX1384.15 |
| MODBUS output process image | MODBUS output variables, addressed by word via MODBUS | Read/ Write | Word %QW1000 to %QW1999 |
| | | | Byte %QB2000 to %QB3999 |
| | MODBUS output variables, addressed by bit via MODBUS | Read/ Write | Bit %QX1000.0 ... %QX1000.15 to %QX1384.0 ... %QX1384.15 |

Table 86: Access to the Process Images of the Input and Output Data – Flags

| Memory area | Description | Access via PLC | Logical Address Space |
|------------------|---|----------------|--|
| Flag variables | Total of 128 kB remanent memory (65536 words). | Read/ Write | %MW0 to %MW65535 |
| | 104 kB addressed by word via MODBUS (53248 words) | Read/ Write | Word (MODBUS) %MW0 to %MW3327 |
| | 6.5 kB addressed by bit via MODBUS (3328 words). | Read/ Write | Bit (MODBUS) %MX0.0 ... %MX0.15 to %MX3327.0 ... %MX3327.15 |
| Retain variables | Retain memory addressed by symbols in the NVRAM: 128 kB | Read/ Write | - |

* The use of up to 250 I/O modules is possible with the WAGO internal data bus extension modules.

The total size of the memory for flag and retain variables is 128 kB (131060 bytes). The size of these two sections can be customized as required, provided the total (permissible) size is not exceeded.

If you are using bit-oriented addressing, remember that the basic address is word-based. The bits are addressed from 0 to 15.

8.8 Addressing Example

The following addressing example clarifies the access to the process image:

Table 87: Arrangement of the I/O modules for the addressing example

| Fieldbus controller | 750-400 | 750-554 | 750-402 | 750-504 | 750-454 | 750-650 | 750-468 | 750-600 |
|---------------------|---------|---------|---------|---------|---------|---------|---------|---------|
| | 1 | 2 | 3 | 4 | 5 | 6 | 7 | 8 |

Table 36: Addressing example

| I/O module | Input data | | Output data | | Description |
|------------|------------|------|-------------|--------|---|
| Type | C* | | | | |
| 750-400 | 1 | | %IX8.0 | | 2DI, 24 V, 3 ms: 1. Digital input module with a data width of 2 bits. As the analog input modules already occupy the first 8 words of the input process image, the 2 bits occupy the lowest-value bits of the 8th word. |
| | 2 | | %IX8.1 | | |
| 750-554 | 1 | | | %QW0 | 2AO, 4 – 20 mA: 1. Analog output module with a data width of 2 words. This module occupies the first 2 words in the output process image. |
| | 2 | | | %QW1 | |
| 750-402 | 1 | | %IX8.2 | | 4DI, 24 V: 2. Digital input module with a data width of 4 bits. These are added to the 2 bits of the 750-400 module and stored in the 8th word of the input process image. |
| | 2 | | %IX8.3 | | |
| | 3 | | %IX8.4 | | |
| | 4 | | %IX8.5 | | |
| 750-504 | 1 | | | %QX4.0 | 4DO, 24 V: 1. Digital output module with a data width of 4 bits. As the analog output module already occupies the first 4 words of the output process image, the 4 bits occupy the lowest-value bits of the 4th word. |
| | 2 | | | %QX4.1 | |
| | 3 | | | %QX4.2 | |
| | 4 | | | %QX4.3 | |
| 750-454 | 1 | %IW0 | | | 2AI, 4 – 20 mA: 1. Analog input module with a data width of 2 words. This module occupies the first 2 words in the input process image. |
| | 2 | %IW1 | | | |
| 750-650 | 1 | %IW2 | | | RS-232, C 9600/8/N/1: The serial interface module is an analog input and output module, which displays 2 words both in the input process image and in the output process image. |
| | | %IW3 | | | |
| | | | | %QW2 | |
| | | | | %QW3 | |
| 750-468 | 1 | %IW4 | | | 4AI, 0 – 10 V S.E: 2. Analog input module with a data width of 4 words. As the 750-454 and 750-650 analog input and output modules already occupy the first 4 words of the input process image, the 4 words of this I/O module are added behind the others. |
| | 2 | %IW5 | | | |
| | 3 | %IW6 | | | |
| | 4 | %IW7 | | | |
| 750-600 | | | | | End module The passive 750-600 end module does not transmit any data. |

Analog input and output modules

Digital input and output modules

*C: Number of the input/output

8.9 Internal Data Bus Synchronization

The internal data bus cycle and the CODESYS task cycle are optimally automatically synchronized: This depends on the number of I/O modules connected and the fastest CODESYS task cycle set in the fieldbus controller. The synchronization cases described below can therefore take place.

In this chapter, CODESYS task denotes only tasks within CODESYS that contain an access to the internal data bus. Tasks that do not access the internal data bus are not synchronized in the same way as described below. For this, see Section “Creating Tasks.”

8.9.1 Case 1: CODESYS Task Interval Set Smaller than the I/O Module Cycle

Execution of the CODESYS tasks is synchronized with internal data bus cycle time.

The CODESYS task is processed in parallel to the internal data bus cycle. The CODESYS task interval is extended to the internal data bus cycle time. This is necessary so that each CODESYS task is started with new input data from the internal data bus and the output values are also set at the module after each CODESYS task.

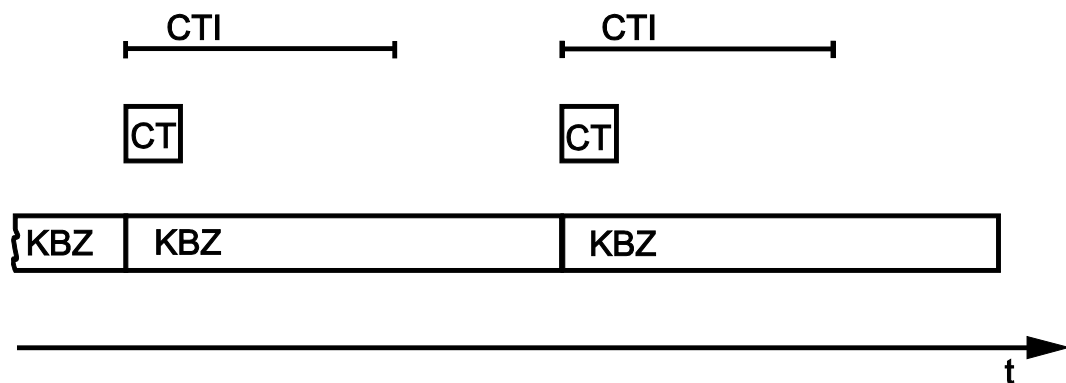

Figure 79: Internal data bus synchronization 01

CTI: CODESYS Task Interval
 CT: CODESYS Task that accesses the I/O module of the internal data bus
 KBZ: Internal Data Bus Cycle

Example:

CODESYS task interval (CTI): 100 μ s

I/O module cycle (KBZ): 2000 μ s

Result: Matching of the CODESYS task interval to the I/O module cycle of 2000 μ s.

8.9.2 Case 2: CODESYS Task Interval Smaller than Twice the Internal Data Bus Cycle

Execution of the internal data bus is synchronized with the set CODESYS task interval.

At the end of the CODESYS task, the internal bus cycle starts, which is processed synchronously with the fastest CODESYS task. This ensures that when starting each CODESYS Task, current input data are available from the internal data bus and the output values of each CODESYS task are also output to the I/O modules.

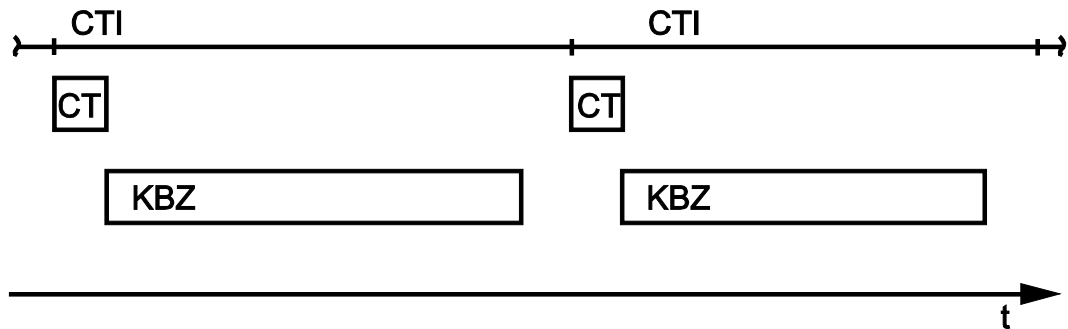

Figure 80: I/O module synchronization 02

CTI: CODESYS Task Interval

CT: CODESYS Task that accesses the I/O module of the internal data bus

KBZ: Internal Data Bus Cycle

Example:

CODESYS task interval (CTI): 2500 μ s

Internal data bus cycle (KBZ): 2000 μ s

Result: Execution of the internal data bus cycle every 2500 μ s.

8.9.3 Case 3: CODESYS Task Interval Greater than Twice the Internal Data Bus Cycle

The I/O data from the internal data bus are refreshed once prior to the CODESYS task and once after the CODESYS task.

Prior to processing the CODESYS task, the internal data bus cycle is executed, which provides the current input data for the CODESYS task. After execution of the CODESYS task, an additional internal data bus cycle is started, which provides the output data to the I/O modules.

This ensures that at the start of every CODESYS task, current input data are available from the internal data bus and the output data from each CODESYS task are quickly output to the I/O modules. This prevents processing of internal data bus cycles that would unnecessarily use a great deal of computing time on the CPU.

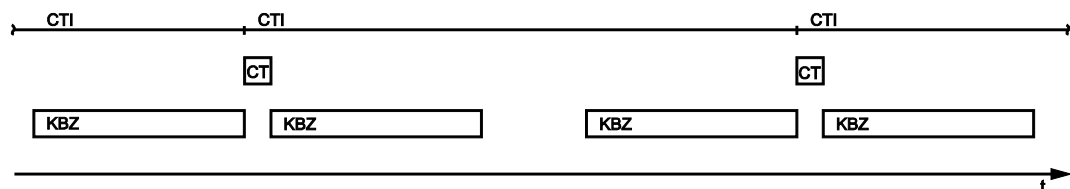

Figure 81: I/O module synchronization 03

CTI: CODESYS Task Interval

CT: CODESYS Task that accesses the I/O module of the internal data bus

KBZ: Internal Data Bus Cycle

Example:

CODESYS task interval (CTI): 500 μ s

Internal data bus cycle (KBZ): 2000 μ s

Result: Execution of the internal data bus cycle 2000 μ s prior to the CODESYS task and once directly after the CODESYS task.

8.9.4 Case 4: CODESYS Task Interval Greater than 10 ms

Synchronization takes place as in case 3; however, the output modules would be reset to their default state after 150 ms without an internal data bus cycle. This reliably prevents the execution of an internal data bus cycle after at least every 10 ms.

The I/O data from the internal data bus are refreshed once before the CODESYS task and once after the CODESYS task and an additional internal data bus cycle is also executed every 10 ms.

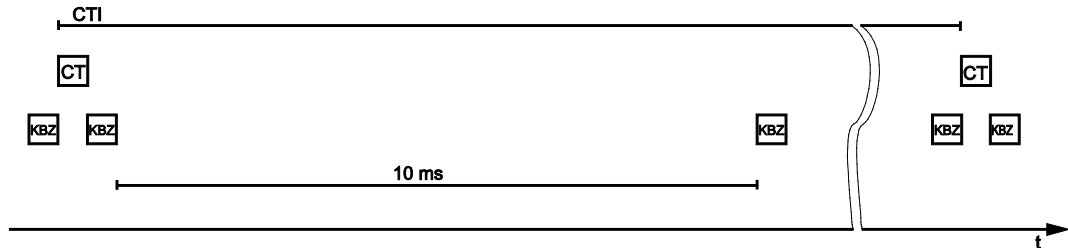

Figure 82: Internal data bus synchronization 04

CTI: CODESYS Task Interval
 CT: CODESYS task that accesses the I/O module of the internal data bus
 KBZ: Internal data bus cycle

Example:

CODESYS task interval (CTI): 150000 μ s

Internal data bus cycle (KBZ): 2000 μ s

Result: Execution of the internal data bus cycle 2000 μ s prior to the CODESYS task, once directly after the CODESYS task and 10 ms after the previous internal data bus cycle.

8.9.5 Internal Data Bus Configuration

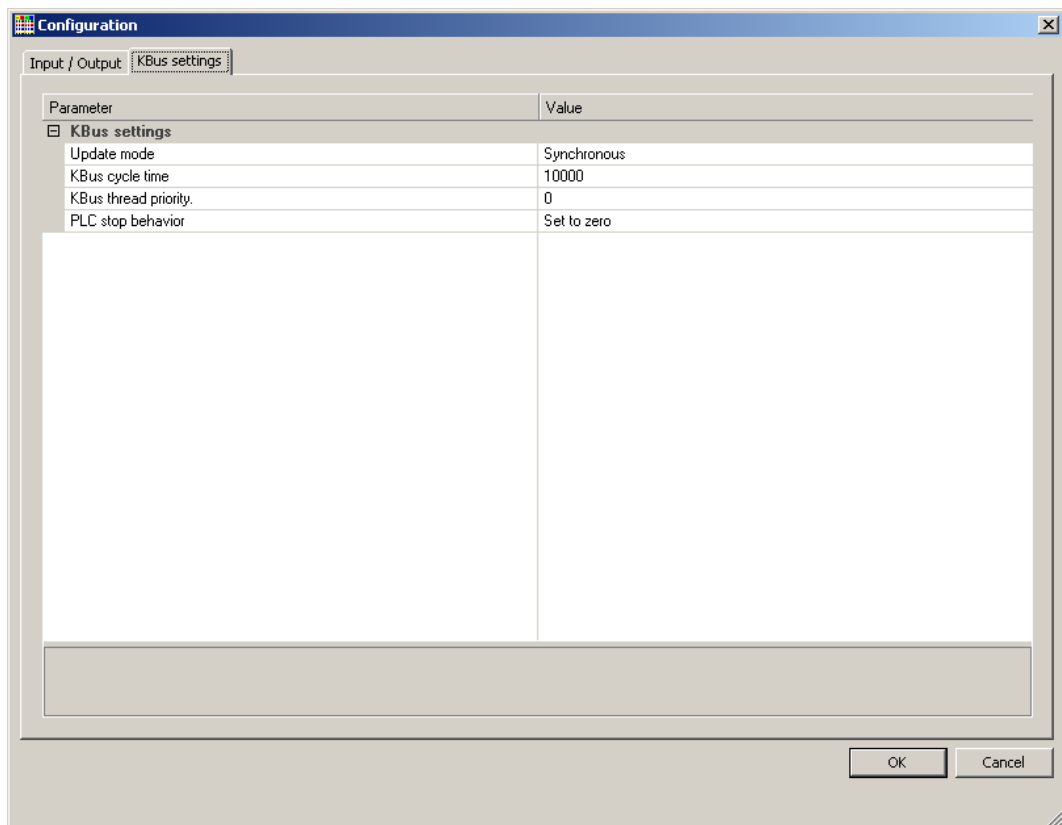

Figure 83: Internal data bus settings

Table 88: Internal Data Bus Settings

| Parameter | Explanation | |
|-----------------------------------|---|--|
| Update Mode | The Update mode is used to configure how the internal data bus process data is to be updated (refreshed). | |
| | Asynchronous | In the asynchronous update mode process data are refreshed in cycles at a definable interval. |
| | Synchronous* | In the synchronous update mode the process data are synchronized with the most rapid CODESYS task that accesses the internal data bus. |
| Internal Data Bus Cycle Time | The update interval for the internal data bus is set by the cycle time. This setting is effective only in the asynchronous mode. | |
| | 1000 μ s | Minimum value 1 millisecond |
| | 10000 μ s* | Default value 10 milliseconds |
| | 50000 μ s | Maximum value 50 milliseconds |
| Internal Data Bus Thread Priority | This value indicates the priority for the internal data bus thread. This setting is effective only in the asynchronous mode. This priority is equivalent to the priority of the cyclic CODESYS tasks (see Section “Cyclic Tasks”). This setting is effective only in the asynchronous mode. | |
| | 0* | Highest priority |
| | 15 | Lowest priority |
| PLC stop response | Specifies the response of the internal data bus outputs when the PLC application stops. | |
| | Hold last value | The output states are retained. |
| | Set to zero* | Outputs are set to zero. |

* Default setting

8.9.5.1 Effect of Update Mode on CODESYS Tasks

8.9.5.1.1 Asynchronous Update Mode

In the asynchronous update mode there is no direct influence on CODESYS task behavior.

Note



Internal data bus “freeze” on priority conflicts!

In the asynchronous update mode there is a risk of the internal data bus “freezing”, as the internal data bus thread operates at the same priority as the IEC tasks. The internal data bus thread must therefore use a priority higher than that of the IEC task to prevent this from occurring.

8.9.5.1.2 Synchronous Update Mode

In the synchronous update mode the runtime behavior of CODESYS tasks can be influenced by the internal data bus. The minimum task interval that can then be achieved depends on the duration of an internal data bus cycle. The duration of an internal data bus cycle, on the other hand, is based on the I/O modules connected to the bus. As a rule of thumb: The shorter the internal data bus structure, the shorter the cycle time and digital modules are faster than analog or complex ones.

In the event of an internal data bus error, the CODESYS tasks are blocked until the error is rectified, i.e., when an internal data bus cycle has been successfully executed again.

Note



No call-up of internal data bus status when internal data bus errors are present!

If an internal data bus error has occurred, it is not possible to call up the internal data bus status using `KBUS_ERROR_INFORMATION (mod_com.lib)` while in the synchronous update mode.

8.10 Memory Settings in CODESYS

The list below illustrates the standard memory allocation of the PFC200:

- Program memory: 16 Mbyte (max.)
- Data memory: 64 Mbytes
- Input data: 64 kbytes
- Output data: 64 kbytes
- Flags: 24 kbytes
- Retain: 104 kbytes
- Function block limitation: $12 * 4096 \text{ bytes} = 48 \text{ kbytes}$

8.10.1 Program Memory

The program memory (also code memory) cannot be configured and is limited to a maximum of 16 Mbytes. The memory space actually available is based on the scope of installed applications.

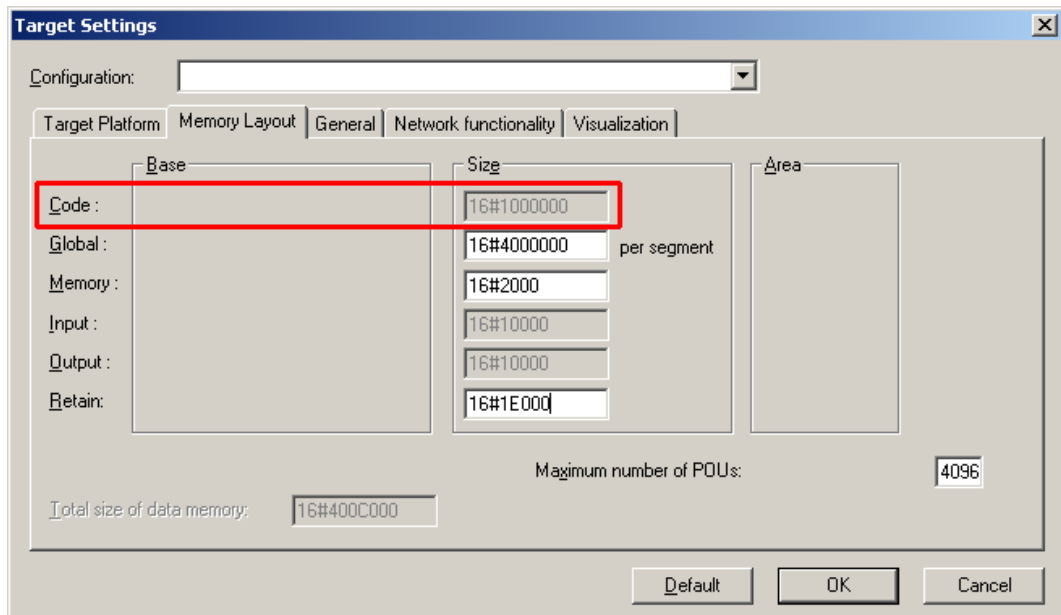

Figure 84: Program memory

8.10.2 Data Memory and Function Block Limitation

The data memory is set for 64 Mbytes in the controller's initial state.

This set value has already been requested after a successful program download in the system and can be utilized to the full extent.

Together with the data memory to be used by the application, memory is required for the individual program function blocks in the system.

The size of the administration space is calculated from the function block limitation * 12 (i.e., normally 4096 * 12).

The sum from the global data memory and function block limitation yields the actual size of the main memory required in the system for data.

This value should not exceed the value specified for “Size of entire data memory”.

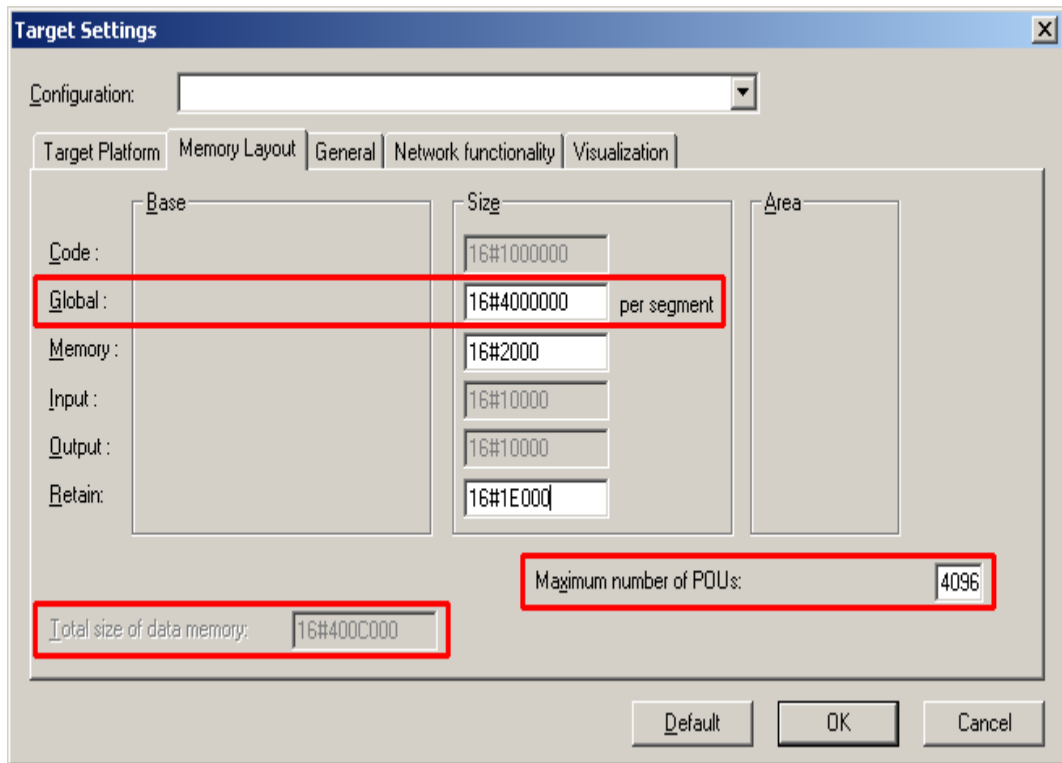

Figure 85: Data memory and function block limitation

8.10.3 Remanent Memory

A total of 128 kbytes of remanent memory is available for the IEC-61131 application.

The remanent section is subdivided into the flag area (memory) and the retain area.

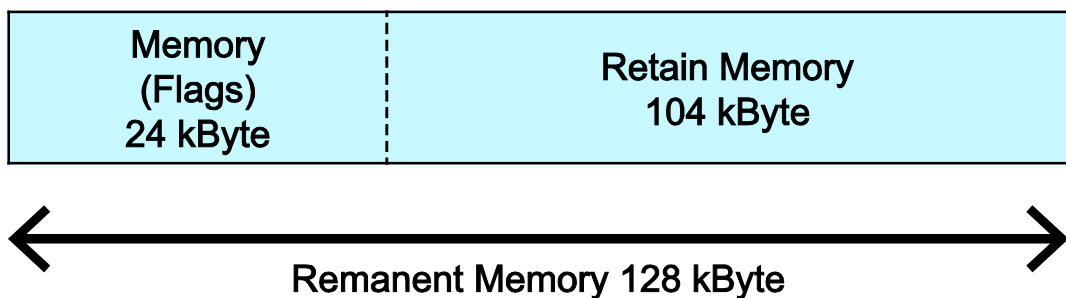

Figure 86: Remanent main memory

The breakdown of the flag and retain variables can be customized as required.

It must be ensured, however, that the sum from Memory + Retain does not exceed the maximum value of 128 kbytes (0x20000).

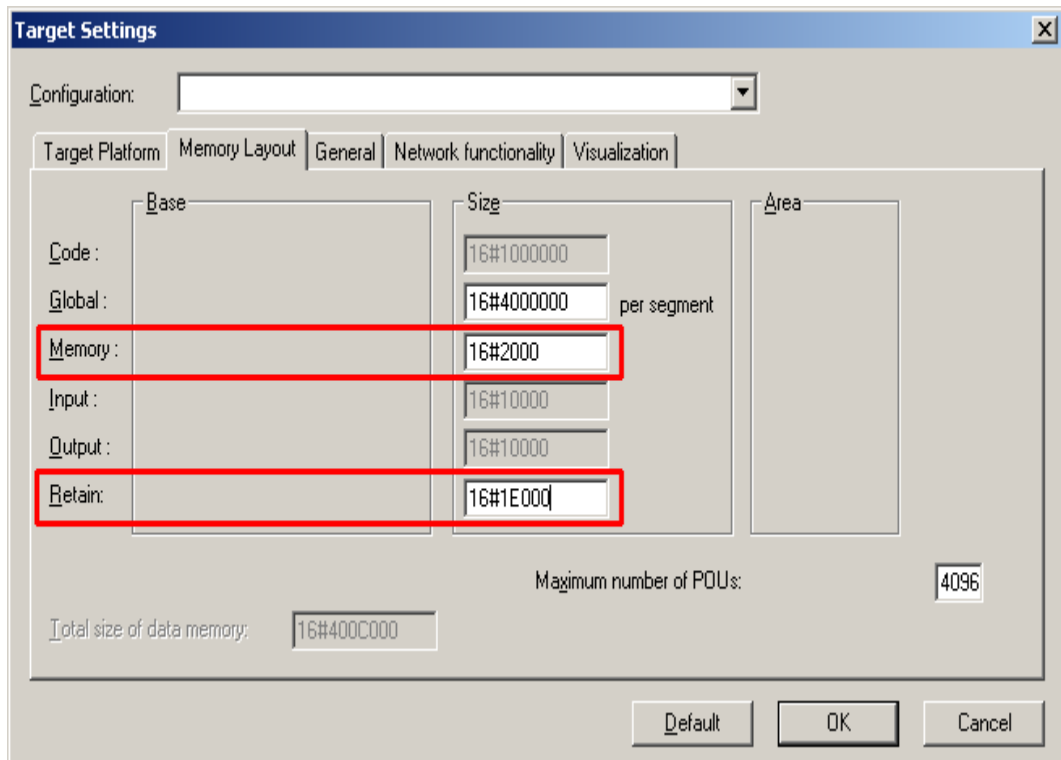

Figure 87: Flag and retain memory

8.11 CODESYS Visualization

CODESYS Web visualization is based on Java technology. All Java programs require a Java runtime environment (JRE), which must be installed on the host PC along with an Internet browser. An applet is stored in the file system of a Web server and is accessible to browsers via an HTML page.

You create all visualization types (HMI and Web visualization) with the same CODESYS graphic editor. Select the visualization type in the “Target system settings” window. A description file in XML format is generated from the information for each of these pages. You can find these files in the subfolder “*visu*” of the CODESYS installation path. The HTML home page “webvisu.htm” and the Java archive “webvisu.jar” in the applet (webvisu.class) are also saved there in a compressed format.

Once you have selected a visualization type, the following steps must be performed to execute the technique:

1. Click the “Resources” tab and open the “Target system settings.” Specify whether you wish to have visualization displayed as a “Web visualization” using an Internet browser.

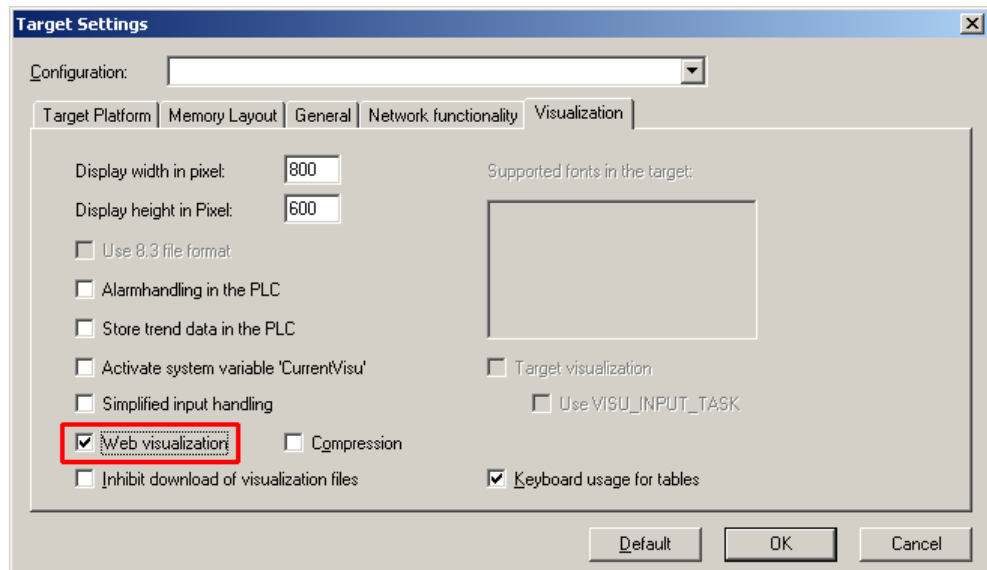

Figure 88: Selecting the visualization technique in the target system settings

2. Generate a start page for the visualization. Right-click the “Visualization” folder in the “Visualization” tab. Select **Add object ...** from the contextual menu. The “New visualization” dialog box opens.

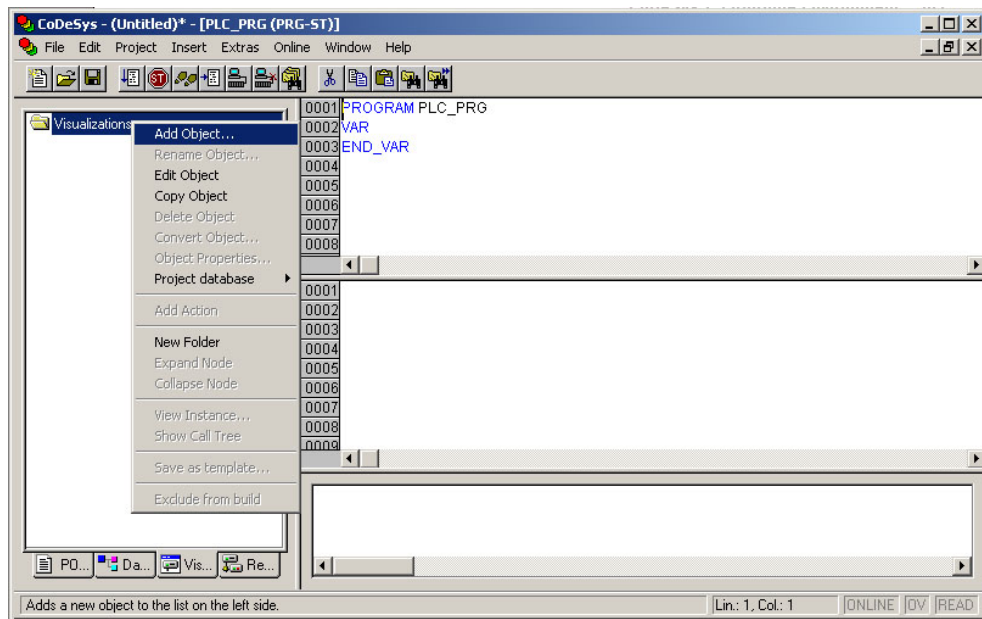

Figure 89: Creating the PLC_VISU starting visualization

3. In the “New visualization” dialog window, enter the name **PLC_VISU** for the start visualization. This page is then displayed as the start page upon system startup.
4. Activate the CODESYS Web server in the WBM on the “Ports and Services – CODESYS Services” page in the “CODESYS Webserver” group.
5. Activate the http service in the WBM on the “Ports and Services – Network Services” page in the “HTTP” group.

If you transfer the PLC program to the controller (**Online > Login**) and start the program (**Online > Start**), enter one of the following lines in the address line of the Web browser for online visualization:

- “https://<IP address of the controller>/webvisu”, preferred method (http can also be used instead of https)
- “https://<IP address of the controller>”, if the default Web server in the WBM has been set to “WebVisu” (http can also be used instead of https)
- “http://<IP address of the controller>:8080/webvisu.htm”

You can also have Web visualization displayed via the WBM (see Section “CODESYS - WebVisu” Page).

Information



Frequently Asked Questions

Additional information (FAQs) on CODESYS Web visualization is also provided in the Section “Frequently Asked Questions about CODESYS Web Visualization” and in the online Help function for CODESYS 2.3.

8.11.1 Limits of CODESYS Visualization

The controller supports the “WebVisu” visualization type integrated into CODESYS. Technological limitations can be caused by the visualization type used.

Compared to “HMI”, Web visualization on the controller is performed within significantly narrower physical limits. Whereas “HMI” can access almost unlimited resources on a desktop PC, the following limitations must be observed when using Web visualization:

Adapting to the File System

The overall size of the PLC program, visualization files, bitmaps, log files, configuration files, etc. must fit into the file system.

Process Data Memory

Web visualization uses its own protocol for exchanging process data between applet and control.

The controller transfers process data with ASCII coding. The pipe symbol (“|”) is used to separate two process values. Therefore, the space requirement for a process data variable in the process data memory is dependent not only on the data type, but also on the process value itself. Thus, a variable of the “WORD” type occupies between one byte for the values 0 through 9 and five bytes for values from 10000 and greater. The selected format (ASCII + |) only permits a rough estimate of the space requirement for the individual process data in the process data buffer. If the size of the ASCII coded process data is exceeded, Web visualization no longer works as expected.

Computer Performance/Processor Time

The controller is based on a real-time operating system. This means that high-priority processes (e.g., PLC program) interrupt or block lower priority processes. The Web server responsible for Web visualization is among these lower priority processes.

Note



Processor Time

Make sure when configuring tasks, that there is sufficient processor time available for all processes.

Network Load

The controller's CPU processes both the PLC program and network traffic. ETHERNET communication demands that each received telegram is processed, regardless of whether it is intended for the controller or not.

A significant reduction of the network load can be achieved by using switches instead of hubs.

There is no measure against broadcast telegrams that can be used on the controller, however. These can only be curtailed by the sender, or blocked with configurable switches that have a broadcast limitation. A network monitor such as “wireshark” (www.wireshark.com) provides an overview of the current load in your network.

8.11.2 Eliminating Errors in CODESYS Web Visualization

If you are experiencing problems when working with the CODESYS Web visualization, use the following table to find the solution. If you cannot eliminate the problem, please contact WAGO support.

Table 89: Errors and remedies

| Error | Solution |
|---|---|
| Internet Explorer reports the error "APPLET NOT INITIATED" | Close all Internet Explorer windows and restart. If the error persists, this indicates a missing or damaged file. Using FTP, check if the entire Java archive "webvisu.jar" is available in the "/PLC" folder of the controller. The original file can be found in the installation path of CODESYS (usually under <i>C:\Programme\WAGO Software\CODESYS V2.3\Visu\webvisu.jar</i>). If necessary, replace the damaged file using FTP or force the download of all files in CODESYS with Purge All > Compile All > Log in . |
| Web visualization is not displayed | Have you installed the JRE? Check the firewall settings, e.g., if port 8080 is open. |
| Web visualization "freezes". Web visualization stops after an extended period of time. | The call-up intervals selected in the task configuration are too small. As a result, the Web server of the controller — which is executed with a low priority — does not receive sufficient computer time, if any at all. If no (explicit) task configuration has been provided, the PLC_PRG is (implicitly) executed as a free running task with Priority 1. This significantly limits the Web server's computing time. Always provide a task configuration when using Web visualization. In doing so, the call-up interval should not exceed three times the average execution time. When determining the execution time, ensure that the PLC program has reached a "steady state." When determining the execution time, ensure that the PLC program is not "steady state." |
| Web visualization cannot be loaded into the controller | Not all files may fit into the controller's file system. Delete any unneeded data (e.g., via FTP). |
| Bitmap is not displayed | If the name of an image file contains umlauts, the Web server cannot interpret these image names. |
| Java console reports: "Class not found" | The JRE does not find the entry point for the class "webvisu.class" in the Java archive "WebVisu.jar". The Java archive is probably incomplete. Delete "WebVisu.jar" from the Java cache and/or deactivate the cache. In this case, the controller requests the archive (applet) again. If the problem persists, reload the project into the controller. |
| Web visualization is static, all process values are "0" | Process data communication has failed. If Web visualization is operated over a proxy server, then a SOCKS proxy is also necessary for process data exchange in addition to the actual HTTP proxy. |

8.11.3 FAQs about CODESYS Web Visualization

How can I optimize the applet for special screen resolutions?

In order to optimize the Web visualization for display on a device with a fixed resolution, proceed as follows:

In the “Target system settings”, enter the pixel width and height in the tab “Visualization”. When the visualization is created, the visible area is highlighted in gray. However, the actual pixel width and height of the Web visualization is defined by the attributes “Height” and “Width” of the HTML APPLET tag in the “webvisu.htm” file. Do not forget to also adapt these parameters to the existing resolution.

Which JRE should I use?

Java2 standard edition Version 1.5.0 (J2SE1.5.0_06) or higher is recommended. This is available free of charge at www.oracle.com.

Microsoft's MSJVM3810 was also tested. For PDAs, there are runtime environments available from other manufacturers (JamaicaVM, CrEme, etc.). Please consider that for the Web visualization, these solutions can behave differently within their scope of services (e.g., stability) than those mentioned above.

Should the Java Cache be used?

This depends on the situation. After a standard installation, the cache is enabled. If the cache is enabled, the JRE uses it to store applets and Java archives. If the Web visualization is called up a second time, it requires considerably less time to start because the applet (approx. 250 kb) does not need to be reloaded via the network, but is already available in the cache. This is especially useful when network connections are slow.

Note:

The Java archives may not be completely transferred into the cache due to network failures. In this case, the cache must be cleared manually or disabled.

Why does the visualization element “TREND” in the Web visualization only work “Online”?

The following settings must be selected for visualization projects: **Resources** tab > **Target system settings**.

Activate “Web visualization” and “Trend data recording within control”.

Otherwise, the trend data is stored on the hard drive of the CODESYS development PC. This makes a permanent connection between the controller and the CODESYS gateway necessary. If this connection is interrupted, this may lead to the controller behaving unpredictably.

In the TREND configuration dialog, you can choose between “Online” and “History” operating modes. The controller only supports the “Online” operating mode for visualization projects since it is not possible to configure the maximum size (quota) of the trend files (*.trd). Uncontrolled expansion of trend files can lead to unpredictable controller behavior.

In most cases, the use of the “HISTOGRAM” visualization element is the better choice, as this gives full control over the time and number of measurements and thus the amount of memory required.

What needs to be observed when the visualization element “ALARM TABLE” is used in the Web visualization?

The status of this component is best described as “Add-On”, i.e., an extra that is free of charge and not warranted.

The following settings must be selected for visualization projects: **Resources** tab > **Target system settings**.

Activate “Web visualization” (checkmark) and “Alarm handling within control”.

Otherwise, the alarm data is processed on the CODESYS development PC. This makes a permanent connection between the controller and the CODESYS gateway necessary. If this connection is interrupted, this may lead to the controller behaving unpredictably.

9 MODBUS

9.1 General

MODBUS is a non-vendor-specific, open fieldbus standard for a wide range of applications in production and process automation. The MODBUS communications protocol is based on a master/slave or client/server architecture that uses function codes for execution of individual MODBUS services, which have reading or writing access to individual or multiple elements of the MODBUS data model simultaneously.

9.2 Features

The MODBUS slave implemented in the PFC200 has the following features:

- 3 modes: MODBUS TCP, MODBUS UDP and MODBUS RTU, which can be run independently of one another simultaneously
- Each mode can be configured
- 10 supported MODBUS services (Function Codes): FC1 to FC6, FC15, FC16, FC22, FC23
- Data exchange via 1000 registers in each of the local MODBUS process images
- 768-byte sector that can be addressed by bits in each local MODBUS process image
- Access to a 104-kB flag sector (total of 53248 registers/words, 3328 bits of which can be addressed)
- 28 Information and configuration registers
- Up to 1000 TCP connections
- MODBUS communications monitoring using programmable watchdogs
- Configurable response on PLC stop
- Configurable response on disruption of MODBUS communication

9.3 Configuration

All of the MODBUS operating modes are configured using the CODESYS control system configuration.

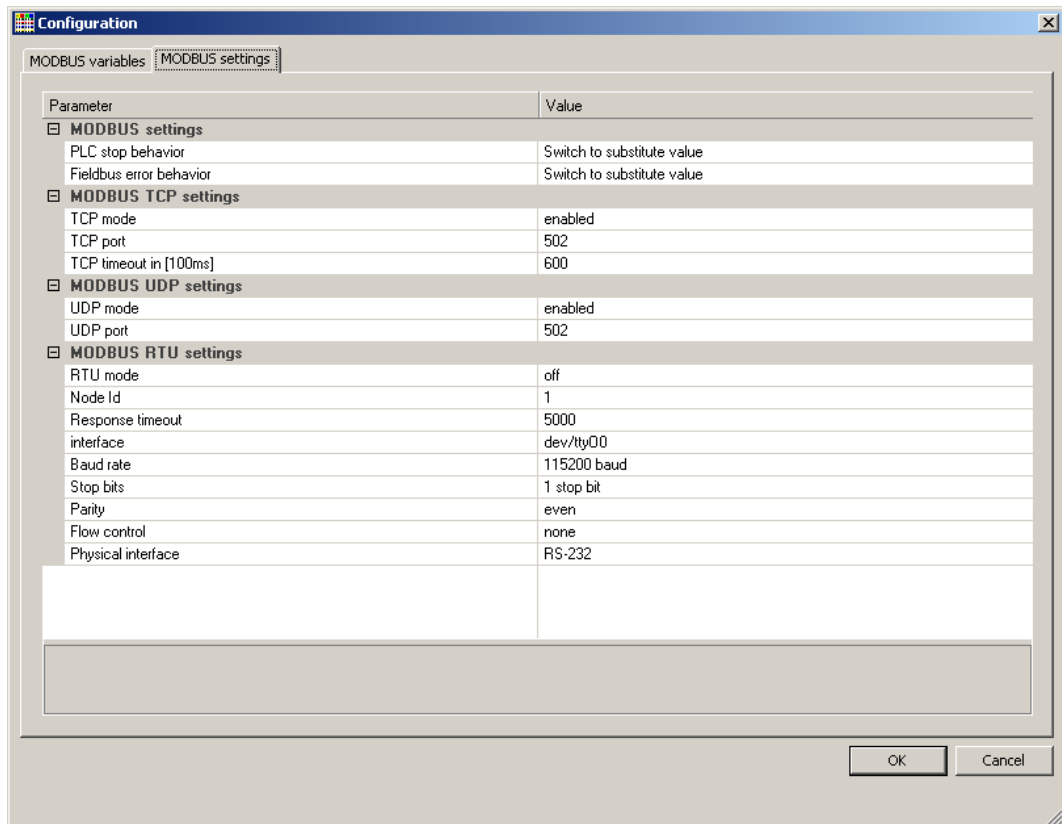

Figure 90: CODESYS control system configuration - MODBUS settings

The MODBUS slave configuration is composed of four basic parameter groups:

- MODBUS settings,
- MODBUS TCP settings,
- MODBUS UDP settings,
- MODBUS RTU settings.

A detailed description of all the parameter groups is given in the following sections.

9.3.1 MODBUS Settings

The “MODBUS settings” group contains the following configuration parameters:

Table 90: MODBUS Settings

| Parameters | Explanation | |
|-------------------------|--|--|
| PLC stop response | Response of the MODBUS slave when the control system has halted (control system in STOP state) | |
| | No data exchange | No data exchange possible. MODBUS requests will always be answered by the exception response "ILLEGAL FUNCTION" (0x81). |
| | Switch to substitute value* | Data exchange possible. Substitute values (0) are provided for MODBUS read requests and the values accepted unchanged in the local MODBUS process image for write requests, without passing these on to the control system. |
| | Hold last value | Data exchange possible. The last frozen values are provided for MODBUS read requests and the values accepted unchanged in the MODBUS process image for write requests, without passing these on to the control system. |
| Fieldbus error response | Response of the MODBUS slave on detected fieldbus errors (interruption of communication). | |
| | No data exchange | No data exchange possible. |
| | Switch to substitute value* | Data exchange possible. Substitute values (0) are supplied from the MODBUS process image for PLC read functions; for write access the values are accepted unchanged in the MODBUS process image without passing them on to the MODBUS master. |
| | Hold last value | Data exchange possible. The previously frozen values are supplied from the MODBUS process image for PLC read functions; for write access the values are accepted unchanged in the MODBUS process image without passing them on to the MODBUS master. |

* Default setting

9.3.2 MODBUS TCP Settings

The “MODBUS TCP Settings” contains the following configuration parameters for the “MODBUS TCP” mode:

Table 91: MODBUS TCP Settings

| Parameters | Explanation | |
|--------------|--------------------------------|---|
| TCP mode | Enable for the MODBUS TCP mode | |
| | Off | Operation not permitted |
| | Active* | Operation possible |
| TCP port | Port number for the TCP link | |
| | 1 | Minimum port number |
| | 502* | MODBUS standard port |
| | 65535 | Maximum port number |
| TCP time-out | Time-out for a TCP link | |
| | 1 | 100 ms (1 x 100 ms) |
| | 600* | 60 seconds (600 x 100 ms) |
| | 65535 | 1 h 49 min 13 s 500 ms (65535 x 100 ms) |

* Default setting

9.3.3 MODBUS UDP Settings

The “MODBUS UDP Settings” group contains the following configuration parameters for the “MODBUS UDP” mode:

Table 92: MODBUS UDP Settings

| Parameters | Explanation | |
|------------|--------------------------------|-------------------------|
| UDP mode | Enable for the MODBUS UDP mode | |
| | Off | Operation not permitted |
| | Active* | Operation possible |
| UDP port | Port number for the UDP link | |
| | 1 | Minimum port number |
| | 502* | MODBUS standard port |
| | 65535 | Maximum port number |

* Default setting

9.3.4 MODBUS RTU Settings

The “MODBUS RTU Settings” group contains the following configuration parameters for the “MODBUS RTU” mode:

Table 93: MODBUS RTU Settings

| Parameters | Explanation | |
|-----------------------|---|--|
| RTU mode | Enable for the MODBUS RTU mode | |
| | Off* | Operation not permitted |
| | Active | Operation possible |
| Device ID | Device ID (device address) for the tty device | |
| | 1* | min. device ID |
| | 247 | max. device ID |
| Maximum response time | Response timeout for a request in [ms] | |
| | 2000 | min. response time = 2 seconds. If this value is set lower than 2 seconds, it will be corrected internally to 2 seconds. |
| | 5000* | Default = 5 seconds |
| | 4294967295 | max. response time > 71 hours. |
| Interface | Device name | |
| | “dev/...” | Name of the tty in the string |
| | “dev/ttyO0”* | Standard tty |
| Baud rate | Communication baud rate | |
| | 1200 baud | 1200 baud min. transmission speed |
| | 2400 baud | 2400 baud |
| | 4800 baud | 4800 baud |
| | 9600 baud | 9600 baud |
| | 19200 baud | 19200 baud |
| | 38400 baud | 38400 baud |
| | 57600 baud | 57600 baud |
| | 115200 baud* | 115200 baud, max. transmission speed |
| Stop bits | Number of stop bits | |
| | 1 stop bit* | 1 stop bit in the frame; must be used when even or odd parity has been selected. |
| | 2 stop bits | 2 stop bits in the frame; must be used when "None" has been selected for parity. |
| Parity | Parity check | |
| | None | No parity check performed; 2 stop bits must be selected in the configuration for this setting. |
| | Even* | Even parity |
| | Odd | Odd parity |

Table 93: MODBUS RTU Settings

| Parameters | Explanation | |
|--------------------|---|---|
| Flow control | Data flow control (Supported only for the setting “RS-232” for the physical interface.) | |
| | None* | No data flow control |
| | RTS/CTS | Hardware flow control |
| Physical interface | Mode for the physical interface | |
| | RS-232* | RS-232 is used as the physical interface. |
| | RS-485 | RS-485 is used as the physical interface. |

* Default setting

9.4 Data Exchange

MODBUS data exchange is performed in cycles or acyclically using MODBUS services. The type and number of usable MODBUS services depends on the area that is addressed. There are generally four MODBUS-relevant address areas in the PFC200:

- **MODBUS input process image** (MODBUS Input) – is an area in the PIO (PIO = Output Process Image), in which data from the PLC is provided in cycles exclusively for MODBUS Read services.
- **MODBUS output process image** (MODBUS Output) – is an area in the PII (PII = Input Process Image), in which MODBUS Write services provide data for cyclic reading by the PLC. MODBUS Read services are also acceptable in this area.
- **MODBUS flag area** – is an area, in which both MODBUS Read and Write services can be executed.
- **MODBUS register** – is an area, in which the WAGO-specific information and configuration registers are contained. Only MODBUS register services may be executed in this area.

9.4.1 Process Image

The main data interfaces between the PLC and the MODBUS slave are the local MODBUS process images in the PLC address area based on IEC 61131. The MODBUS input process image (MODBUS Input) is in the PIO and the MODBUS output process image (MODBUS Output) in the PII. Data memory blocks of 2 kB (1000 registers/word) are available for each local MODBUS input and output process image. The first 768 bytes of each of these data blocks are also provided for executing bit services.

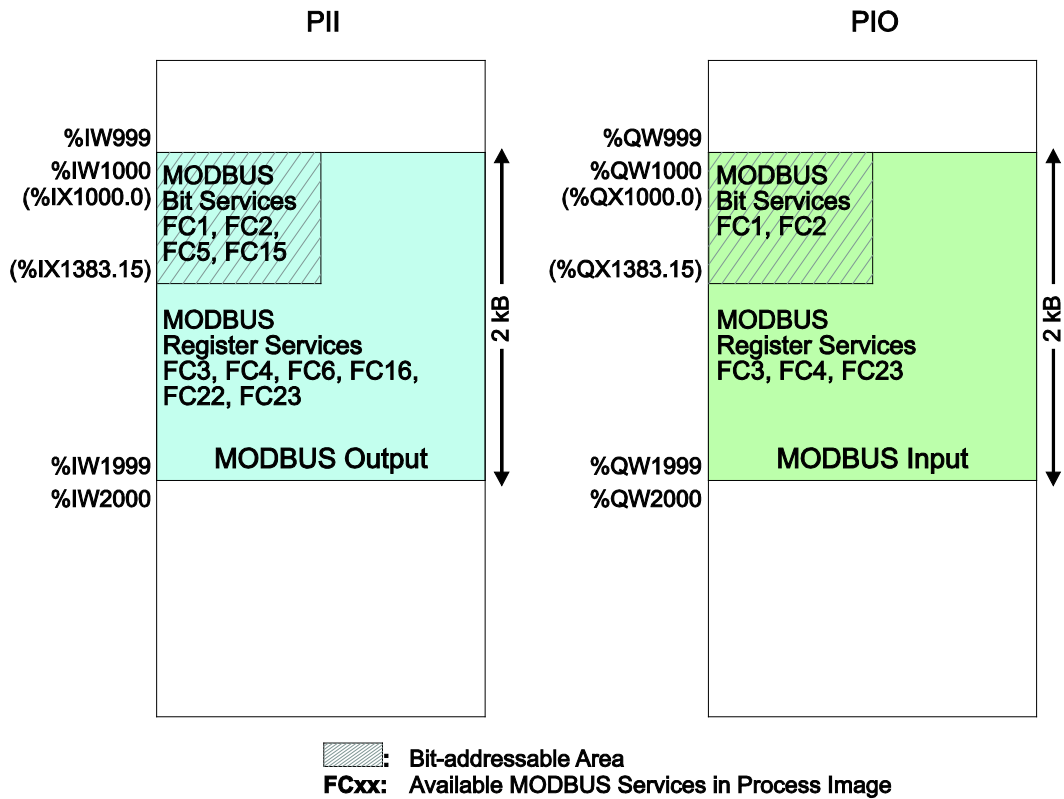

Figure 91: MODBUS process image

As no direct access to the I/O modules is provided by the fieldbus, data can be exchanged via this interface between the PLC and MODBUS for processing in the control system (PLC). Using this data in the individual I/O modules connected to the PLC can then be performed by the application.

9.4.2 Flag Area

MODBUS can also exchange data and fieldbus variables with the PLC via the flag area. Caution is urged, however, when using data and/or variables in this area that is accessed by both MODBUS and the PLC. This “conflicting” access is not protected from either side and could result in data inconsistency.

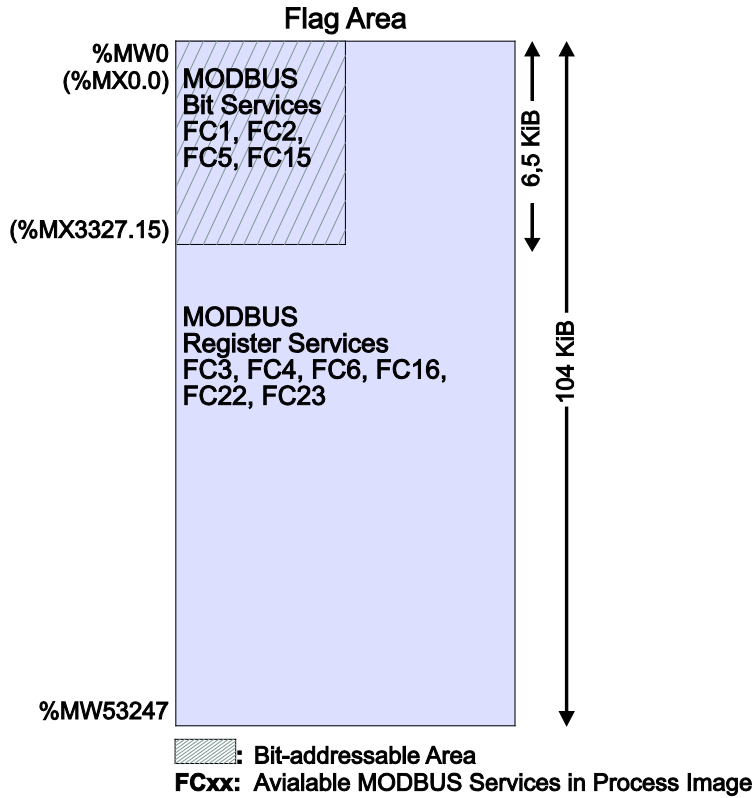

Figure 92: Flag area

9.4.3 MODBUS Registers

WAGO-specific registers are implemented in the last MODBUS-relevant address area; this simplifies the reading of certain system and MODBUS information, as well as configuration.

The MODBUS address area reserved for these registers ranging from the MODBUS starting address of 4096 (0x1000) up to the MODBUS end address of 12287 (0x2FFF), without any allocation to the IEC 61131 address area. These registers can be queried using the register read services FC3, FC4 and FC23 and with the register write services FC6, FC16, FC22 and FC23. A detailed description of the individual registers is given in the Section “WAGO MODBUS Registers”.

9.4.4 MODBUS Mapping

9.4.4.1 MODBUS Mapping for Write Bit Services FC1, FC2

The table below outlines the mapping for the MODBUS-reading, bit-oriented services:

- FC1 – Read Single Coil,
- FC2 – Read Discrete Inputs.

Table 94: MODBUS Mapping for Read Bit Services FC1, FC2

| MODBUS Address (hexadecimal values in parentheses) | IEC 61131 Address | Description |
|--|-----------------------------|--|
| 0 ... 6143 (0x0000 ... 0x17FF) | %IX1000.0 ... %IX1383.15 | MODBUS Output: 6144 PFC input bit variables in the first 384 registers/words (768 bytes) of the 2kB MODBUS output process image in the PII. Note: In this area, the read bit services return the content from the bit-addressed PII. |
| 6144 ... 12287 (0x1800 ... 0x2FFF) | %QX1000.0 ... %QX1383.15 | MODBUS Input: 6144 PFC output bit variables in the first 384 registers/words (768 bytes) of the 2 kB MODBUS-input process image in the PIO. |
| 12288 ... 65535 (0x3000 ... 0xFFFF) | %MX0.0 ... %MX3327.15 | Flag area: 53248 bit flags (6.5 kB) in the bit-addressed flag area |

9.4.4.2 MODBUS Mapping for Write Bit Services FC5, FC15

The table below outlines the mapping for the MODBUS-writing, bit-oriented services:

- FC5 – Write Single Coil
- FC15 – Write Multiple Coils

Table 95: MODBUS mapping for write bit services FC5, FC15

| MODBUS Address (hexadecimal values in parentheses) | IEC 61131 Address | Description |
|---|---|--|
| 0 ... 6143 (0x0000 ... 0x17FF) | %IX1000.0 ... %IX1383.15 | MODBUS Output: 6144 PFC input bit variables in the first 384 registers/words (768 bytes) of the 2kB MODBUS output process image in the PII. |
| 6144 ... 12287 (0x1800 ... 0x2FFF) | %QX1000.0 ... %QX1383.15 | MODBUS Output: MODBUS-only area for bit-oriented write access. Bit-based write services for this area are acknowledged by the MODBUS slave with the MODBUS exception code “ILLEGAL DATA ADDRESS” (0x02). |
| 12288 ... 65535 (0x3000 ... 0xFFFF) | %MX0.0 ... %MX3327.15 | Flag area: 53248 bit flags (6.5 kB) in the bit- addressed flag area |

9.4.4.3 MODBUS Mapping for Read Register Services FC3, FC4, FC23

The table below outlines the mapping for the MODBUS-reading, register-oriented services:

- FC3 – Read Holding Registers,
- FC4 – Read Input Registers,
- FC23 – Read/Write Multiple Registers

Table 96: MODBUS Mapping for Read Register Services FC3, FC4, FC23

| MODBUS Address (hexadecimal values in parentheses) | IEC 61131 Address | Description |
|--|------------------------|---|
| 0 ... 999 (0x0000 ... 0x03E7) | %IW1000 ... %IW1999 | MODBUS Output: 1000 PFC input registers/words in the 2 kB MODBUS output process image in the PII. Note: In this area, the read register services return the content from the PII. |
| 1000 ... 1999 (0x03E8 ... 0x07CF) | %QW1000 ... %QW1999 | MODBUS Input: 1000 PFC output registers/words in the 2 kB MODBUS input process image in the PIO. Note on FC23: Only the Read portion of this service can be executed. |
| 2000 ... 4095 (0x07D0 ... 0x0FFF) | X | Inhibited to MODBUS-only area for register-oriented read access. Register- based read services for this area are acknowledged by the MODBUS slave with the MODBUS exception code “ILLEGAL DATA ADDRESS” (0x02). |
| 4096 ... 12287 (0x1000 ... 0x2FFF) | X | Information and configuration registers: Not all MODBUS addresses in this range are valid. Valid MODBUS addresses are described in the Section “WAGO MODBUS Registers”. Access to invalid addresses are acknowledged by the MODBUS slave with the MODBUS exception code “ILLEGAL DATA ADDRESS” (0x02). Note on FC23: The Write portion of this service can only be executed for registers that data can be written to. |

Table 96: MODBUS Mapping for Read Register Services FC3, FC4, FC23

| MODBUS Address (hexadecimal values in parentheses) | IEC 61131 Address | Description |
|---|------------------------------|--|
| 12288 ... 65535 (0x3000 ... 0xFFFF) | %MW0 ... %MW53247 | Flag Area: 53248 register/word flags (104 kB) in the flag area |

9.4.4.4 MODBUS Mapping for Write Register Services FC6, FC16, FC22, FC23

The table below outlines the mapping for MODBUS-writing, register-oriented services.

- FC6 – Write Single Register,
- FC16 – Write Multiple Registers,
- FC22 – Mask Write Register,
- FC23 – Read/Write Multiple Registers.

Table 97: MODBUS mapping for write register services FC6, FC16, FC22, FC23

| MODBUS Address (hexadecimal values in parentheses) | IEC 61131 Address | Description |
|---|--|---|
| 0 ... 999 (0x0000 ... 0x03E7) | %IW1000 ... %IW1999 | MODBUS Output: 1000 PFC input registers/words in the 2 kB MODBUS output process image in the PII. |
| 1000 ... 1999 (0x03E8 ... 0x07CF) | No access to: %QW1000 ... %QW1999 | MODBUS Output: Inhibited MODBUS area for register- oriented write access. Register-oriented write services in this area are acknowledged by the MODBUS slave with the MODBUS exception code “ILLEGAL DATA ADDRESS” (0x02). |
| 2000 ... 4095 (0x07D0 ... 0x0FFF) | | Inhibited MODBUS area for register- oriented write access. Register-oriented write services in this area are acknowledged by the MODBUS slave with the MODBUS exception code “ILLEGAL DATA ADDRESS” (0x02). |
| 4096 .. 12287 (0x1000 ... 0x2FFF) | No IEC 61131 address | Information and Configuration Registers: Not all MODBUS addresses in this area are valid and not all registers can be written to. Valid MODBUS addresses are described in the Section “WAGO MODBUS Registers”. Access to invalid addresses are acknowledged by the MODBUS slave with the MODBUS exception code “ILLEGAL DATA ADDRESS” (0x02). |

Table 97: MODBUS mapping for write register services FC6, FC16, FC22, FC23

| MODBUS Address (hexadecimal values in parentheses) | IEC 61131 Address | Description |
|---|------------------------------|--|
| 12288 ... 65535 (0x3000 ... 0xFFFF) | %MW0 ... %MW53247 | Flag Area: 53248 register/word flags (104 kB) in the flag area |

9.5 WAGO MODBUS Register

System and MODBUS data can be read and some MODBUS parameters configured using the WAGO MODBUS registers. The following table lists all of the WAGO MODBUS registers.

Table 98: WAGO MODBUS Registers

| MODBUS Address | | Data Length in Words | Access | Description |
|----------------|--------|-------------------------|--------|---|
| Dec. | Hex. | | | |
| 4130 | 0x1022 | 1 | ro | Number of registers in the MODBUS input process image in the PIO |
| 4131 | 0x1023 | 1 | ro | Number of registers in the MODBUS output process image in the PII |
| 4132 | 0x1024 | 1 | ro | Number of bits in the MODBUS input process image in the PIO |
| 4133 | 0x1025 | 1 | ro | Number of bits in the MODBUS output process image in the PII |
| 4136 | 0x1028 | 1 | ro | IP configuration: BootP(1), DHCP(2) or fixed, coded IP address(4) |
| 4138 | 0x102A | 1 | ro | Number of established TCP connections |
| 4144 | 0x1030 | 1 | r/w | MODBUS TCP Timeout (Changes apply only to new connections) |
| 4145 | 0x1031 | 3 | ro | MAC ID of the ETHERNET interface (eth0) |
| 4151 | 0x1037 | 1 | r/w | MODBUS TCP response delay |
| 4160 | 0x1040 | 1 | ro | PLC status |
| 4352 | 0x1100 | 1 | wo | Watchdog Command |
| 4353 | 0x1101 | 1 | ro | WatchdogStatus |
| 4354 | 0x1102 | 1 | rw | Watchdog Timeout (configuration register) |
| 4355 | 0x1103 | 1 | rw | Watchdog Config (configuration register) |
| 8192 | 0x2000 | 1 | ro | 0x0000 (constant) |
| 8193 | 0x2001 | 1 | ro | 0xFFFF (constant) |
| 8194 | 0x2002 | 1 | ro | 0x1234 (constant) |
| 8195 | 0x2003 | 1 | ro | 0xAAAA (constant) |
| 8196 | 0x2004 | 1 | ro | 0x5555 (constant) |

Table 98: WAGO MODBUS Registers

| MODBUS Address | | Data Length in Words | Access | Description |
|----------------|--------|-------------------------|--------|---------------------------|
| Dec. | Hex. | | | |
| 8197 | 0x2005 | 1 | ro | 0x7FFF (constant) |
| 8198 | 0x2006 | 1 | ro | 0x8000 (constant) |
| 8199 | 0x2007 | 1 | ro | 0x3FFF (constant) |
| 8200 | 0x2008 | 1 | ro | 0x4000 (constant) |
| 8208 | 0x2010 | 1 | ro | Revision (Firmware Index) |
| 8209 | 0x2011 | 1 | ro | Series code |
| 8210 | 0x2012 | 1 | ro | Device code |
| 8211 | 0x2013 | 1 | ro | Major Firmware Version |
| 8212 | 0x2014 | 1 | ro | Minor Firmware Version |
| 8213 | 0x2015 | 1 | ro | MBS Version |

The WAGO MODBUS registers are described in more details in the following sections.

9.5.1 Process Image Properties

9.5.1.1 Register 0x1022 – Number of Registers in the MODBUS Input Process Image

This register contains the number of registers available in the MODBUS input process image (MODBUS input).

9.5.1.2 Register 0x1023 – Number of Registers in the MODBUS Output Process Image

This register contains the number of registers available in the MODBUS output process image (MODBUS output).

9.5.1.3 Register 0x1024 – Number of Bits in the MODBUS Input Process Image

This register contains the number of bits available in the MODBUS input process image (MODBUS input).

9.5.1.4 Register 0x1025 – Number of Bits in the MODBUS Output Process Image

This register contains the number of bits available in the MODBUS output process image (MODBUS output).

9.5.2 Network Configuration

9.5.2.1 Register 0x1028 – IP Configuration

This register contains information about the set IP configuration.

Possible values:

- 1 = BootP
- 2 = DHCP
- 4 = Fixed IP address

9.5.2.2 Register 0x102A – Number of Established TCP Connections

This register supplies the number of established TCP connections.

The maximum number of MODBUS TCP connections is 1000.

9.5.2.3 Register 0x1030 – MODBUS TCP Socket Timeout

This register contains the timeout value for the TCP sockets.

This value is given in units of 100ms (ticks). A new value is accepted only for new connections which have not yet been established. In the event of any changes, pre-established connections will continue to operate using the previously set timeout value.

9.5.2.4 Register 0x1031 – MAC Address for ETHERNET-Interface 1 (eth0)

This register provides the MAC address for the first ETHERNET interface (eth0). MAC may also provide a partial result.

9.5.2.5 Register 0x1037 - MODBUS TCP Response Delay

This register saves the value of the MODBUS response delay.

This value is specified in ms units. The maximum delay is 32 ms, default value is 0 ms (no delay). Transmission of the response to a MODBUS request is delayed from the time of processing (read and/or write register values) by the time set. In the meantime, incoming requests can only be processed when the previous response is sent. For MODBUS UDP, this applies to all requests and for MODBUS TCP, for each connection. The actual length of time between a MODBUS request and the associated response depends on the number of parallel requests overall system utilization; it is always greater than the response delay set. Changes to the response delay become effective immediately for each subsequent request.

9.5.3 PLC Status Register

Register 0x1040 provides the status (state) that the controller is currently in.
Possible values:

- 1 = PLC running – PLC status is RUNNING.
- 2 = PLC stopped – PLC status is STOPPED.

9.5.4 MODBUS Watchdog

The MODBUS watchdog monitors ongoing MODBUS communication. In the event that the configured monitoring time (see “Watchdog Timeout” Register) is exceeded without one single valid MODBUS query (trigger) being received from a MODBUS slave, the watchdog reacts and initiates the “Watchdog Timeout” reaction (previously configured in the “Watchdog Config” register). The watchdog must be continuously triggered by the MODBUS master to ensure that the set monitoring time does not expire. Triggering is performed by receiving any arbitrary MODBUS query from the entire volume of services supported by the MODBUS slave. These MODBUS-slave-supported services are listed in the Section “MODBUS Mapping”. The Explicit Trigger Mode is an exception to this rule and is elucidated in detail in the description of the “MODBUS Config” register (0x1103).

9.5.4.1 Register 0x1100 – Watchdog Command

This register receives commands for the MODBUS watchdog.
The following commands are accepted:

Table 99: Watchdog Commands

| Value | Name | Explanation |
|--------|---------------------|--|
| 0x5555 | WATCHDOG_START | Starts the watchdog |
| | Error-free response | Watchdog has been successfully started, or restarted, and has the status "Running". |
| | Error response | ILLEGAL FUNCTION (0x01) ILLEGAL DATA VALUE (0x03) |
| 0x55AA | WATCHDOG_STOP | Stops the watchdog |
| | Error-free response | Watchdog was stopped successfully and has the status "Stopped". |
| | Error response | ILLEGAL FUNCTION (0x01) ILLEGAL DATA VALUE (0x03) |
| 0xAAAA | WATCHDOG_RESET | Resets the watchdog after a timeout |
| | Error-free response | Watchdog was reset successfully and has the status "Stopped" or "Unconfigured" when the "Watchdog Timeout" register (0x1102) contains the value 0. |
| | Error response | ILLEGAL DATA VALUE (0x03) |

The watchdog is only started by the command WATCHDOG_START. A prerequisite for successful startup is a valid timeout value in the "Watchdog Timeout" register (0x1102) and the status "Stopped" or "Running" (for restart), which the watchdog must have (see "Watchdog Status" register 0x1101). A response of ILLEGAL_DATA_VALUE indicates that the watchdog has not yet been configured (status "Unconfigured", timeout value is "0"). If the watchdog has the status "Expired", the WATCHDOG_START command is also rejected by the ILLEGAL_FUNCTION acknowledgement.

A running watchdog can be stopped by the command WATCHDOG_STOP. A stop request received several times in a row does not have any impact on the behavior of the watchdog and is therefore not acknowledged with an error response. By contrast, a stop command received when the watchdog has the status "Unconfigured" is rejected with the acknowledgement ILLEGAL_DATA_VALUE; if the watchdog has the status "Expired" this command is rejected by the exception code ILLEGAL_FUNCTION.

If the watchdog monitoring time has expired, the watchdog can only be reset by the command WATCHDOG_RESET. The watchdog cannot be restart until this

command is executed. Resetting the watchdog does not necessarily restart it automatically, however. To restart the watchdog after a reset, the command WATCHDOG_START must be sent. Possible reactions to expiring of the watchdog monitoring time (timeout) are described in the “Watchdog Config” register (0x1102). If the command WATCHDOG_RESET is received when the watchdog has a status other than “Expired”, this command is rejected with the exception code ILLEGAL_DATA_VALUE.

9.5.4.2 Register 0x1101 – Watchdog Status

This register provides the current status of the MODBUS watchdog. The watchdog can have any of the four following statuses:

Table 100: Watchdog Status

| Value | Name | Explanation |
|--------|-----------------------|--|
| 0xFFFF | WATCHDOG_UNCONFIGURED | Watchdog not configured, i.e., the watchdog time-out register (0x1102) contains the value 0. |
| 0x0000 | WATCHDOG_STOPPED | Watchdog is not active (not started). |
| 0x0001 | WATCHDOG_RUNNING | Watchdog is active (started). |
| 0x0002 | WATCHDOG_EXPIRED | Watchdog monitoring time has expired. |

If the “Watchdog Timeout” register (0x1102) contains the value 0, the Watchdog has not been configured – WATCHDOG_UNCONFIGURED. If the timeout value remains unchanged (0), the Watchdog cannot leave this state. After a configuration, the Watchdog switches to “Stopped” and can now be started.

The watchdog can only be started by the command WATCHDOG_START. When the watchdog is started, it assumes the status “Running” - WATCHDOG_RUNNING. Configuration changes in this state are no longer possible.

When the watchdog expires (status WATCHDOG_EXPIRED), the registers “Watchdog Status” (0x1101), “Watchdog Timeout” (0x1102) and “Watchdog Config” (0x1103) are the only registers that can be read. Access to other registers, with the exception of write access to the “Watchdog Command” register (0x1100), and bit access is acknowledged by the error ILLEGAL_FUNCTION.

The configuration registers can only be written in the watchdog statuses WATCHDOG_UNCONFIGURED, WATCHDOG_STOPPED or WATCHDOG_EXPIRED. Only read access is permitted for these registers in the status WATCHDOG_RUNNING.

9.5.4.3 Register 0x1102 – Watchdog Timeout

This configuration register contains the watchdog timeout value. As the basic unit is 100 ms, the timeout value must be a multiple of 100 ms. Thus, the minimum timeout value can be set to 100 ms, while the maximum value can be set to 6553.5 seconds. If this value is 0, the watchdog cannot be started and will have the status

“Unconfigured”. The watchdog timeout register can be rewritten to the states “Unconfigured”, “Stopped” or “Expired”. Access to this register is read only while the watchdog is active.

9.5.4.4 Register 0x1103 – Watchdog Config

This register contains the configuration parameters for the watchdog. The following parameters can be configured:

Table 101: Watchdog Configuration

| Bit | Name/Bit Identifier | Explanation |
|-----|---|--|
| 0 | Explicit triggering EXPLICIT_TRIGGER_ONLY | Controls explicit triggering |
| | | 0 All supported MODBUS queries are considered watchdog triggers (default setting). There is a special rule for the “Watchdog Status” register. See the description for bit 1 EXPLICIT_TRIGGER_ON_STATUS_REG. |
| 1 | Triggering by access to the watchdog status register TRIGGER_ON_STATUS_REG | 1 Explicit Trigger Mode – only the command WATCHDOG_START (0x5555), sent to the “Watchdog Command” register (0x1100), or reading of the “Watchdog Status” registers (0x1101), when Bit 1 EXPLICIT_TRIGGER_ON_STATUS_REG has been set accordingly, are considered valid trigger events for the MODBUS watchdog. |
| | | 0 Read access to the “Watchdog Status” register is not considered a trigger event (default setting). |
| 2 | Close-down of established TCP connections CLOSE_ALL_TCP_CONNECTIONS | Controls triggering by read-only access to the “Watchdog Status” register |
| | | 1 Read access to the “Watchdog Status” register is considered a trigger event. |
| | | Closes down all established TCP connections |
| | | 0 All established connections remain open. |
| | | 1 All established connections are closed (default setting). |

The individual options are activated when the specific bit, or bit combination, is set.

The “Watchdog Config” register can be rewritten to the statuses “Unconfigured”, “Stopped” or “Expired”. Access to this register is read only while the watchdog is active.

9.5.5 MODBUS Constants Register

Registers 0x2000 ... 0x2008 provide constants based on the table “WAGO MODBUS Register”. It is possible to read all of the constants, or a consecutive portion of them, at once.

9.5.6 Electronic Nameplate

Registers 0x2010 to 0x2015 contain information from the electronic nameplate. It is possible to read the entire nameplate, or a consecutive portion of it, all at once.

9.5.6.1 Register 0x2010 – Revision (Firmware Index)

This register provides the consecutive revision index (firmware index) for the PFC200.

Example: 5 for Version 5.

9.5.6.2 Register 0x2011 – Series Designator

This register provides the designation for the WAGO series (Series Code) of the PFC200.

Example: 750 for WAGO-I/O SYSTEM 750.

9.5.6.3 Register 0x2012 – Device ID

This register provides the device ID (WAGO Item No.) of the controller.

Example: 8206.

9.5.6.4 Register 0x2013 – Major Firmware Version

This register provides the major part for the firmware version.

9.5.6.5 Register 0x2014 – Minor Firmware Version

This register provides the minor part for the firmware version.

9.5.6.6 Register 0x2015 – MBS Version

This register provides the version of the MODBUS slave library. The high byte contains the major version number and the low byte, the minor version number.

Example:

0x010A => Major version number = 1, Minor version number = 10.

9.6 Diagnostics

9.6.1 Diagnostics for the MODBUS Master

The status of the PLC, or of the control system, can be queried by the MODBUS master by reading the WAGO-specific register 0x1040 – “PLC Status” using MODBUS services FC3 (Read Holding Registers) or FC4 (Read Input Registers). The WAGO-specific register 0x1040 – “PLC Status” is explained in the Section “PLC Status Registers”.

The status of the MODBUS Watchdog can be requested using a register service (FC3 or FC4) with a query to the WAGO-specific register 0x1101 – “Watchdog Status Register”. Information about this is given in the Section “MODBUS Watchdog”.

The MODBUS service “Get Communication Event Counter” (FC11) is not supported in the current MODBUS slave Version V1.0.

9.6.2 Diagnostics for the Runtime System

Diagnostics for the MODBUS slaves can be executed by integrating the CODESYS library “BusDiag.lib” via the runtime system. The required function block, “DiagGetBusState() indicates the status of the fieldbus (here MODBUS) and is located in this library. Details about this function block are provided both in this document and in the online Help function for CODESYS.

9.6.3 Diagnostics for the Error Server

The MODBUS slave also supports the error service implemented in the PFC and generates diagnostic messages, which are stored permanently (in a file), or temporarily (in the RAM) and can be displayed directly via the WBM client. The following diagnoses are generated by the MODBUS slave:

Table 102: Diagnostics for the Error Server

| Diagnosics ID | Diagnostic text | Method of saving | Explanation |
|---------------|-------------------------------|------------------|--|
| 0x00090000 | Modbus Slave library loaded | Temporary | MODBUS slave library has been successfully loaded. |
| 0x00090001 | Modbus Slave library closed | Temporary | MODBUS slave library has been successfully unloaded. |
| 0x00090002 | Modbus Slave TCP started | Temporary | MODBUS slave successfully started in TCP mode. |
| 0x00090003 | Modbus Slave TCP start failed | Permanent | Starting the MODBUS slave in the TCP mode failed. |
| 0x00090004 | Modbus Slave TCP terminated | Temporary | MODBUS slave TCP mode successfully terminated. |
| 0x00090005 | Modbus Slave UDP started | Temporary | MODBUS slave successfully started in UDP mode. |
| 0x00090006 | Modbus Slave UDP start failed | Permanent | Starting the MODBUS slave in UDP mode failed. |

Table 102: Diagnostics for the Error Server

| Diagnostics ID | Diagnostic text | Method of saving | Explanation |
|-----------------------|---|-------------------------|--|
| 0x00090007 | Modbus Slave UDP terminated | Temporary | MODBUS slave UDP mode successfully terminated. |
| 0x00090008 | Modbus Slave RTU started | Temporary | MODBUS slave successfully started in the RTU mode. |
| 0x00090009 | Modbus Slave RTU start failed | Permanent | Starting the MODBUS slave in RTU mode failed. |
| 0x0009000A | Modbus Slave RTU terminated | Temporary | MODBUS slave RTU mode successfully terminated. |
| 0x0009000B | Modbus Slave data exchange started by PLC | Temporary | MODBUS slave data exchange started. |
| 0x0009000C | Modbus Slave data exchange stopped by PLC | Temporary | MODBUS slave data exchange stopped. |
| 0x0009000F | Modbus Slave PLC watchdog timer expired | Permanent | Monitoring time for controller (PLC) expired. |
| 0x00090100 | Modbus Slave common configuration failed. | Permanent | MODBUS slave configuration failed. |
| 0x00090101 | Modbus Slave TCP configured successfully. | Temporary | MODBUS slave TCP configuration completed successfully. |
| 0x00090102 | Modbus Slave TCP configuration failed. | Permanent | MODBUS slave TCP configuration failed. |
| 0x00090103 | Modbus Slave UDP configured successfully | Temporary | MODBUS slave UDP configuration completed successfully. |
| 0x00090104 | Modbus Slave UDP configuration failed. | Permanent | MODBUS slave UDP configuration failed. |
| 0x00090105 | Modbus Slave RTU configured successfully. | Temporary | MODBUS slave RTU configuration completed successfully. |
| 0x00090106 | Modbus Slave RTU configuration failed | Permanent | MODBUS slave RTU configuration failed. |
| 0x00090107 | Port for Modbus Slave RTU operation not free. | Permanent | Serial port for MODBUS slave RTU configuration already occupied. |

Table 102: Diagnostics for the Error Server

| Diagnostics ID | Diagnostic text | Method of saving | Explanation |
|-----------------------|--|-------------------------|--|
| 0x00090108 | Modbus Slave RTU configuration in RS-485 mode failed. | Permanent | MODBUS slave RTU configuration for the RS-485 mode has failed. |
| 0x00090200 | Modbus Slave Watchdog activated. | Temporary | MODBUS watchdog activated. |
| 0x00090201 | Modbus Slave Watchdog deactivated. | Temporary | MODBUS watchdog deactivated. |
| 0x00090202 | Modbus Slave Watchdog Timer expired. | Permanent | MODBUS watchdog monitoring time expired. |
| 0x00090203 | Modbus Slave has terminated all established TCP connections. | Permanent | All MODBUS TCP connections terminated due to timeout. |
| 0x00090300 | Modbus Slave: obtaining system resource failed | Permanent | Request for system resources by the MODBUS slave has failed. |
| 0x00090301 | Modbus Slave: processing system resource failed. | Permanent | Access to system resources by the MODBUS slave has failed. |

10 Diagnostics

10.1 Operating and Status Messages

The following tables contain descriptions of all operating and status messages for the controller which are indicated by LEDs.

10.1.1 Power Supply Indicating Elements

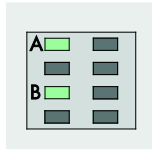

Figure 93: Power supply indicating elements

Table 103: Legend for Figure “Power Supply Indicating Elements”

| Description | Color | Description |
|-------------|-----------|---|
| A | Green/off | Status of system power supply voltage |
| B | Green/off | Status of field-side power supply voltage |

Table 104: Field-Side Supply Diagnostics

| Status | Explanation | Solution |
|--------|--|---|
| Green | 24V field-side supply voltage present | --- |
| Off | No 24V field-side supply voltage present | Switch on the power supply. Check the supply voltage. |

Table 105: System Power Supply Diagnostics

| Status | Explanation | Solution |
|--------|--|---|
| Green | 24V system power supply voltage present | --- |
| Off | No 24V system power supply voltage present | Switch on the power supply. Check the supply voltage. |

10.1.2 Fieldbus/System Indicating Elements













U6   SYS
 U5   RUN
 U4   I/O
 U3   MS
 U2   NS
 U1   U7

Figure 94: Indicating elements for fieldbus/system

Table 106: Diagnostics SYS LED

| Status | Explanation | Solution |
|-----------------|--|--|
| Green | System start completed without errors | --- |
| Orange | Usage > Limit 1 The system is at full capacity; real-time response can no longer be guaranteed. | Try to reduce the load on the system: <ul style="list-style-type: none"> - Change the CODESYS program. - End any fieldbus communication that is not essential, or reconfigure the fieldbuses. - Remove any non-critical tasks from the RT area. |
| Orange flashing | The IP address was temporarily set to a defined value via the FIC IP function with the RST button. | Connect to the device via the standard address (192.168.1.17), or restart the device to restore the set value. |
| Red | Usage > Limit 2 The system is overloaded; real-time response is no longer guaranteed. | Try to reduce the load on the system: <ul style="list-style-type: none"> - Change the CODESYS program. - End any fieldbus communication that is not essential, or reconfigure the fieldbuses. - Remove any non-critical tasks from the RT area. |

Table 107: Diagnostics RUN LED

| Status | Explanation | Solution |
|--------------------|---|---|
| Green | PLC program has the status "Run". | --- |
| Green flashing | PLC program at a debug point. | Resume the program in the linked IDE (Integrated Development Environment) using "Single step" or "Start". If the connection has been interrupted, set the Run/Stop switch to "Stop" and then back to "Run" to enable the program to continue. |
| Green/red flashing | PLC is at a debug point and the Run/Stop switch has been set to "Stop". | Set the Run/Stop switch to "Run" to enable the program to continue. |
| Red | No PLC-program loaded or PLC program has the status "Stop". | Load the PLC program. Set the Run/Stop switch to "Run" to start the current program. |

Table 108: Diagnostics I/O LED

| Status | Explanation | Solution |
|----------------------------------|--|---|
| Green | Data cycle on the internal data bus, normal operating status. | --- |
| Orange flashing | Startup phase; the internal data bus is being initialized. The startup phase is indicated by rapid flashing for about 1 ... 2 seconds. | Wait until initialization has been completed. |
| Red | A hardware fault is present. | Contact WAGO Support. |
| Red flashing (2 Hz) | An error which may be able to be eliminated is present. | First, try to eliminate the error by switching the device (power supply) off and then back on. Check the entire node structure for any errors. If you cannot eliminate the error, contact WAGO Support. |
| Red flashing (flashing sequence) | An internal data bus error is present. | An explanation of the flashing sequence is given in the section "Diagnostics Messages (I/O LEDs)". |
| Off | A library was not loaded, or a library function was not called up. | Restart the device. If you cannot eliminate the error, contact WAGO Support. |

10.2 Diagnostics Messages (I/O LED)

10.2.1 Flashing Sequence

A diagnosis (fault/error) is always displayed as three flashing sequences in a cyclic manner:

1. The first flashing sequence (flickering) initiates reporting of the fault/error.
2. After a short break (approx. 1 second), the second flashing sequence starts. The number of blink pulses indicates the **error code**, which describes the type of error involved.
3. After a further break the third flashing sequence is initiated. The number of blink pulses indicates the **error argument**, which provides an additional description of the error, e.g., which of the I/O modules connected to the controller exhibits an error.

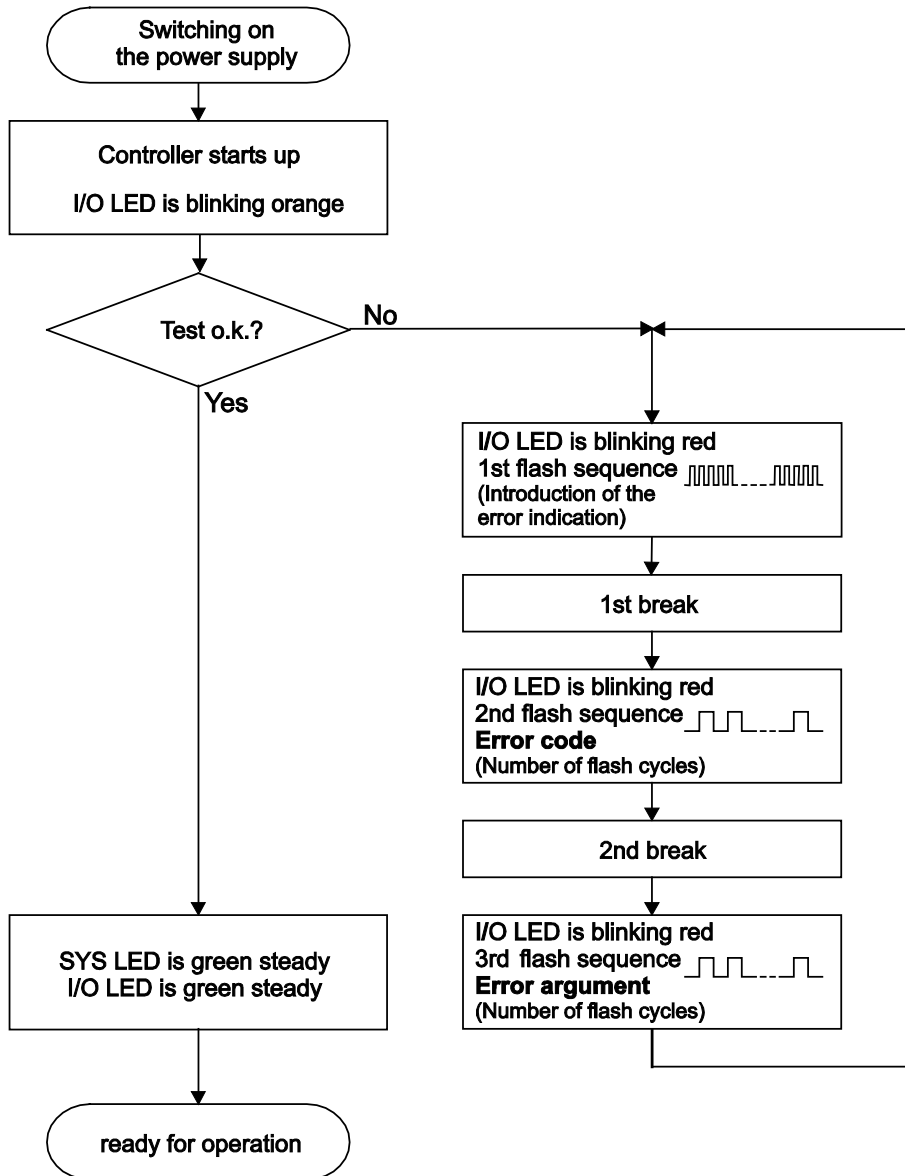

Figure 95: Flashing sequence process diagram

10.2.2 Example of a Diagnostics Message Indicated by a Blink Code

The example below illustrates the representation of a diagnostics message via the blink code. A data error is indicated on the internal data bus, caused by the removal of an I/O module located at the 6th position of the bus node.

Initiation of the Start Phase

1. The I/O LED flashes for 1 cycle at about 10 Hz (10 flashes/second).
2. This is followed by a pause of about one second.

Error Code 4: Data Error in the Internal Data Bus

3. The I/O LED flashes for 4 cycles of about 1Hz.
4. This is followed by a pause of about 1 second.

Error Argument 5: I/O Module at the 6th Slot

5. The I/O LED flashes for 5 cycles at 1 Hz.
This indicates that a disruption has occurred at the I/O module downcircuit of the 5th I/O module.
6. The blink code starts flickering when the start phase is initiated again. If there is only one error, this process is repeated.

10.2.3 Meaning of Blink Codes and Procedures for Troubleshooting

This section describes the diagnostics presented as blink codes via the I/O LEDs.

If the diagnostics cannot be cleared by the measured specified for them, contact WAGO support. Be ready to explain to them the blink code that is displayed.

Phone: +49 571 887 555
Fax: +49 571 887 8555
E-mail: support@wago.com

Table 109: Overview of Error Codes

| Error code | Explanation |
|------------|---|
| 1 | Hardware and configuration error |
| 2 | Not used |
| 3 | Internal data bus protocol error |
| 4 | Physical error on the internal data bus |
| 5 | Internal data bus initialization error |
| 6 | Design error in the node configuration |
| 7 | Not used |
| 8 | Not used |
| 9 | CPU exception error |

Table 110: Error Code 1, Explanation of Blink Codes and Procedures for Troubleshooting

| Error Argument | Cause | Solution |
|----------------|---|--|
| -- | Invalid parameter checksum for internal data bus interface | <ul style="list-style-type: none"> - Switch off the power to the controller and replace it. - After this, switch the power back on. |
| 1 | Internal buffer overflow (max. amount of data exceeded) during inline code generation | <ul style="list-style-type: none"> - Switch off the power to the controller. - Reduce the number of I/O modules. - Switch the power back on. |
| 2 | Data type of the I/O module(s) is not supported | <ul style="list-style-type: none"> - Update the controller firmware. If this error persists, there is an error in the I/O module. Determine this error as follows: - Switch off the power supply. - Place the end module in the middle of the I/O modules connected to the system. - Switch the power back on. - If the I/O flashes red switch off the power supply again and place the end module in the middle of the first half of the I/O modules (toward the controller). - If the LED is no longer flashing, switch off the power supply and place the end module in the middle of the second half of the I/O modules (away from the controller). - Switch the power back on. - Repeat this procedure until you establish which I/O module is defective. Then replace that module. |
| 3 | Unknown module type of the flash program memory | <ul style="list-style-type: none"> - Switch off the power to the controller and replace it. - After this, switch the power back on. |
| 4 | Error occurred while writing to the flash memory | <ul style="list-style-type: none"> - Switch off the power to the controller and replace it. - After this, switch the power back on. |
| 5 | Error occurred while erasing a flash sector | |
| 6 | The I/O module configuration after an internal data bus reset differs from the one after the last controller startup. | <ul style="list-style-type: none"> - Restart the controller by first switching off the power supply and then switching it back on, or by pressing the Reset button on the controller. |
| 7 | Error occurred while writing to the serial EEPROM | <ul style="list-style-type: none"> - Switch off the power to the controller and replace it. - After this, switch the power back on. |

Table 110: Error Code 1, Explanation of Blink Codes and Procedures for Troubleshooting

| Error Argument | Cause | Solution |
|-----------------------|--|--|
| 8 | Invalid hardware/ firmware combination | |
| 9 | Invalid checksum in the serial EEPROM | |
| 10 | Fault when initializing the serial EEPROM. | |
| 11 | Error occurred while reading from the serial EEPROM | <ul style="list-style-type: none"> - Switch off the power supply to the controller and reduce the number of I/O modules. - After this, switch the power back on. |
| 12 | Time to access the serial EEPROM exceeded | <ul style="list-style-type: none"> - Switch off the power to the controller and replace it. - After this, switch the power back on. |
| 14 | Maximum number of gateway or mailbox modules exceeded. | <ul style="list-style-type: none"> - Switch off the power to the controller. - Reduce the number of gateway or mailbox modules. - After this, switch the power back on. |

Table 111: Error Code 3, Explanation of Blink Codes and Procedures for Troubleshooting

| Error Argument | Cause | Solution |
|----------------|--|--|
| -- | Internal data bus communication error; defective I/O module cannot be identified | <p>If a power supply module (e.g., 750-602) is connected to the controller, ensure that this module functions properly (see Section “LED Signaling”). If the supply module does not exhibit any errors/faults, the I/O module is defective. Identify the defective I/O module as follows:</p> <ul style="list-style-type: none"> - Switch off the power supply. - Place the end module in the middle of the I/O modules connected to the system. - Switch the power back on. - If the I/O LED continues to flash red switch off the power supply again and place the end module in the middle of the first half of the I/O modules (toward the controller). <p>If only one I/O module is left and the LED continues to flash, either this module or the controller internal data bus interface is defective. Replace the defective module or the controller.</p> <ul style="list-style-type: none"> - If the LED is no longer flashing, switch off the power supply and place the end module in the middle of the second half of the I/O modules (away from the controller). - Switch the power back on. - Repeat this procedure until you establish which I/O module is defective. Then replace that module. |

Table 112: Error Code 4, Explanation of Blink Codes and Procedures for Troubleshooting

| Error Argument | Cause | Solution |
|----------------|---|--|
| -- | Maximum permissible number of I/O modules exceeded. | <ul style="list-style-type: none"> - Switch off the power to the controller. - Reduce the number of I/O modules to an acceptable value. - Switch the power back on. |
| n* | Internal data bus disruption after the n th process data module. | <ul style="list-style-type: none"> - Switch off the power to the controller. - Replace the (n+1)th process data module. - Switch the power back on. <p>I/O modules that do not provide any data are ignored (e.g., supply module without diagnostics).</p> |

Table 113: Error Code 5, Explanation of Blink Codes and Procedures for Troubleshooting

| Error Argument | Cause | Solution |
|----------------|--|--|
| n* | Register communication error during internal data bus initialization | <ul style="list-style-type: none"> - Switch off the power to the controller. - Replace the (n+1)th process data module. - Switch the power back on. <p>I/O modules that do not provide any data are ignored (e.g., supply module without diagnostics).</p> |

Table 114: Error Code 6, Explanation of Blink Codes and Procedures for Troubleshooting

| Error Argument | Cause | Solution |
|----------------|--|--|
| 5 | Maximum size of the process image exceeded | <ul style="list-style-type: none"> - Switch off the power supply to the controller and reduce the number of I/O modules. - Switch the power back on. |

Table 115: Error Code 9, Explanation of Blink Codes and Procedures for Troubleshooting

| Error Argument | Cause | Solution |
|-----------------------|---------------------------|--|
| 1 | Invalid program statement | Malfunction of the program sequence. - Please contact WAGO Support. |
| 2 | Stack overflow | Malfunction of the program sequence. - Please contact WAGO Support. |
| 3 | Stack underflow | Malfunction of the program sequence. - Please contact WAGO Support. |
| 4 | Invalid event (NMI) | Malfunction of the program sequence. - Please contact WAGO Support. |

11 Service

11.1 Inserting and Removing the Memory Card

11.1.1 Inserting the Memory Card

1. Use an actuating tool or a screwdriver to open the transparent cover flap by flipping it upwards. The points of application for the tool are marked by arrows.
2. Hold the memory card such that the contacts are visible on the right side and the sloping edge is at the top, as depicted in the figure below.
3. Insert the memory card in this position into the slot of the fieldbus controller.
4. Push the memory card all the way in. When you let go, the memory card will move back a little and then snap in.
5. Close the cover flap by flipping it down and pushing it in until it snaps into place.
6. You can seal the closed flap through the hole in the enclosure next to the flap.

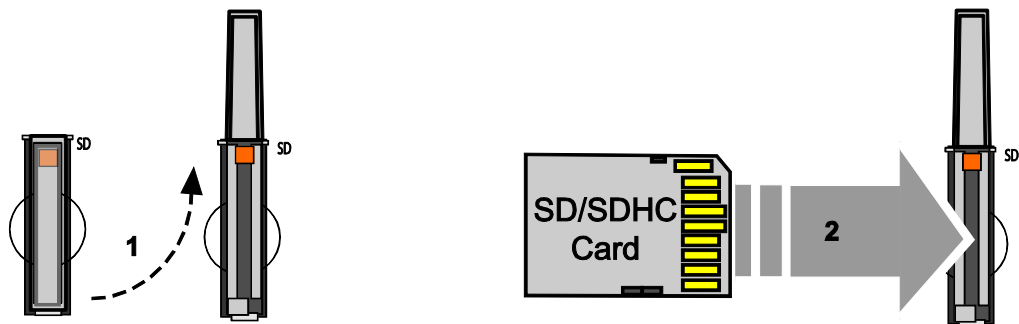

Figure 96: Inserting the memory card

11.1.2 Removing the Memory Card

1. First, remove any seal that may be in place.
2. Use an actuating tool or a screwdriver to open the transparent cover flap by flipping it upwards. The points of application for the tool are marked by arrows.
3. To remove the memory card you must first push it into the slot. This releases the mechanical locking mechanism.
4. As soon as you let go of the memory card, the memory card is pushed out a bit and you can remove it.

5. Close the cover flap by flipping it down and pushing it in until it snaps into place.

12 Removal

⚠ CAUTION

Risk of injury due to sharp-edged blade contacts!

The blade contacts are sharp-edged. Handle the I/O module carefully to prevent injury.

12.1 Removing Devices

NOTICE

Perform work on devices only if they are de-energized!

Working on energized devices can damage them. Therefore, turn off the power supply before working on the devices.

12.1.1 Removing the Fieldbus Coupler/Controller

1. Use a screwdriver blade to turn the locking disc until the nose of the locking disc no longer engages behind the carrier rail.
2. Remove the fieldbus coupler/controller from the assembly by pulling the release tab.

Electrical connections for data or power contacts to adjacent I/O modules are disconnected when removing the fieldbus coupler/controller.

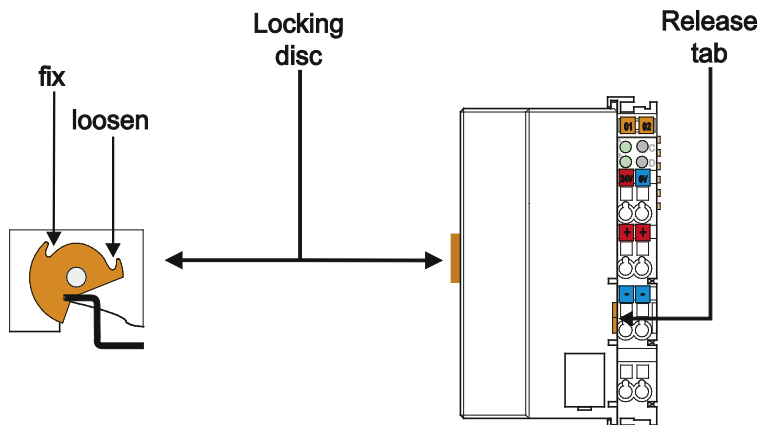

Figure 97: Release Tab of Controller

Note



Do not take the controller enclosure apart!

The enclosure sections are firmly joined. The feed-in section with the CAGE CLAMP® connections cannot be separated from the other enclosure section.

12.1.2 Removing the I/O Module

1. Remove the I/O module from the assembly by pulling the release tab.

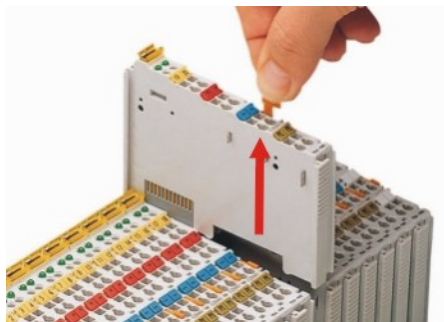

Figure 98: Removing the I/O Module (Example)

Electrical connections for data or power jumper contacts are disconnected when removing the I/O module.

Note



Do not take the controller enclosure apart!

The enclosure sections are firmly joined. The feed-in section with the CAGE CLAMP® connections cannot be separated from the other enclosure section.

13 Appendix

13.1 Structure of Process Data for the I/O Modules

The process image for the I/O modules on the internal data bus is built up word-by-word in the PFC200 controller (with word alignment). The internal mapping method for data greater than one byte conforms to Intel formats.

The following section describes the representation for WAGO-I/O SYSTEM 750 (750 and 753 Series) I/O modules in the process image, as well as the configuration of the process values.

NOTICE

Equipment damage due to incorrect address!

To prevent any damage to the device in the field you must always take the process data for all previous byte or bit-oriented I/O modules into account when addressing an I/O module at any position in the fieldbus node.

Note



No direct access from fieldbus to the process image for I/O modules!

Any data that is required from the I/O module process image must be explicitly mapped in the CODESYS program to the data in the fieldbus process image and vice versa! Direct access is not possible!

13.1.1 Digital Input Modules

Digital input modules supply one bit of data per channel to specify the signal state for the corresponding channel. These bits are mapped into the Input Process Image.

Some digital modules have an additional diagnostic bit per channel in the Input Process Image. The diagnostic bit is used for detecting faults that occur (e.g., wire breaks and/or short circuits).

When analog input modules are also present in the node, the digital data is always appended after the analog data in the Input Process Image, grouped into bytes.

13.1.1.1 1 Channel Digital Input Module with Diagnostics

750-435

Table 116: 1 Channel Digital Input Module with Diagnostics

| Input Process Image | | | | | | | |
|---------------------|-------|-------|-------|-------|-------|--------------------|---------------|
| Bit 7 | Bit 6 | Bit 5 | Bit 4 | Bit 3 | Bit 2 | Bit 1 | Bit 0 |
| | | | | | | Diagnostic bit S 1 | Data bit DI 1 |

13.1.1.2 2 Channel Digital Input Modules

750-400, -401, -405, -406, -410, -411, -412, -427, -438, (and all variations),
753-400, -401, -405, -406, -410, -411, -412, -427

Table 117: 2 Channel Digital Input Modules

| Input Process Image | | | | | | | |
|---------------------|-------|-------|-------|-------|-------|-------------------------|-------------------------|
| Bit 7 | Bit 6 | Bit 5 | Bit 4 | Bit 3 | Bit 2 | Bit 1 | Bit 0 |
| | | | | | | Data bit DI 2 Channel 2 | Data bit DI 1 Channel 1 |

13.1.1.3 2 Channel Digital Input Module with Diagnostics

750-419, -421, -424, -425,
753-421, -424, -425

Table 118: 2 Channel Digital Input Module with Diagnostics

| Input Process Image | | | | | | | |
|---------------------|-------|-------|-------|------------------------------|------------------------------|-------------------------|-------------------------|
| Bit 7 | Bit 6 | Bit 5 | Bit 4 | Bit 3 | Bit 2 | Bit 1 | Bit 0 |
| | | | | Diagnostic bit S 2 Channel 2 | Diagnostic bit S 1 Channel 1 | Data bit DI 2 Channel 2 | Data bit DI 1 Channel 1 |

13.1.1.4 2 Channel Digital Input Module with Diagnostics and Output Process Data

750-418,
753-418

The digital input module supplies a diagnostic and acknowledge bit for each input channel. If a fault condition occurs, the diagnostic bit is set. After the fault condition is cleared, an acknowledge bit must be set to re-activate the input. The diagnostic data and input data bit is mapped in the Input Process Image, while the acknowledge bit is in the Output Process Image.

Table 119: 2 Channel Digital Input Module with Diagnostics and Output Process Data

| Input Process Image | | | | | | | |
|---------------------|-------|-------|-------|---------------------------------|---------------------------------|----------------------------|----------------------------|
| Bit 7 | Bit 6 | Bit 5 | Bit 4 | Bit 3 | Bit 2 | Bit 1 | Bit 0 |
| | | | | Diagnostic bit S 2 Channel 2 | Diagnostic bit S 1 Channel 1 | Data bit DI 2 Channel 2 | Data bit DI 1 Channel 1 |

| Output Process Image | | | | | | | |
|----------------------|-------|-------|-------|--------------------------------------|--------------------------------------|-------|-------|
| Bit 7 | Bit 6 | Bit 5 | Bit 4 | Bit 3 | Bit 2 | Bit 1 | Bit 0 |
| | | | | Acknowledgement bit Q 2 Channel 2 | Acknowledgement bit Q 1 Channel 1 | 0 | 0 |

13.1.1.5 4 Channel Digital Input Modules

750-402, -403, -408, -409, -414, -415, -422, -423, -428, -432, -433, -1420, -1421, -1422, -1423
753-402, -403, -408, -409, -415, -422, -423, -428, -432, -433, -440

Table 120: 4 Channel Digital Input Modules

| Input Process Image | | | | | | | |
|---------------------|-------|-------|-------|----------------------------|----------------------------|----------------------------|----------------------------|
| Bit 7 | Bit 6 | Bit 5 | Bit 4 | Bit 3 | Bit 2 | Bit 1 | Bit 0 |
| | | | | Data bit DI 4 Channel 4 | Data bit DI 3 Channel 3 | Data bit DI 2 Channel 2 | Data bit DI 1 Channel 1 |

13.1.1.6 8 Channel Digital Input Modules

750-430, -431, -436, -437, -1415, -1416, -1417, -1418
753-430, -431, -434

Table 121: 8 Channel Digital Input Modules

| Input Process Image | | | | | | | |
|----------------------------|----------------------------|----------------------------|----------------------------|----------------------------|----------------------------|----------------------------|----------------------------|
| Bit 7 | Bit 6 | Bit 5 | Bit 4 | Bit 3 | Bit 2 | Bit 1 | Bit 0 |
| Data bit DI 8 Channel 8 | Data bit DI 7 Channel 7 | Data bit DI 6 Channel 6 | Data bit DI 5 Channel 5 | Data bit DI 4 Channel 4 | Data bit DI 3 Channel 3 | Data bit DI 2 Channel 2 | Data bit DI 1 Channel 1 |

13.1.1.7 8 Channel Digital Input Module PTC with Diagnostics and Output Process Data

750-1425

The digital input module PTC provides via one logical channel 2 byte for the input and output process image.

The signal state of PTC inputs DI1 ... DI8 is transmitted to the fieldbus coupler/controller via input data byte D0.

The fault conditions are transmitted via input data byte D1.

The channels 1 ... 8 are switched on or off via the output data byte D1. The output data byte D0 is reserved and always has the value "0".

Table 122: 8 Channel Digital Input Module PTC with Diagnostics and Output Process Data

| Input Process Image | | | | | | | | | | | | | | | |
|------------------------------|------------------------------|------------------------------|------------------------------|------------------------------|------------------------------|------------------------------|------------------------------|--|--|--|--|--|--|--|--|
| Input Byte D0 | | | | | | | | Input Byte D1 | | | | | | | |
| Bit 7 | Bit 6 | Bit 5 | Bit 4 | Bit 3 | Bit 2 | Bit 1 | Bit 0 | Bit 7 | Bit 6 | Bit 5 | Bit 4 | Bit 3 | Bit 2 | Bit 1 | Bit 0 |
| Signal status DI 8 Channel 8 | Signal status DI 7 Channel 7 | Signal status DI 6 Channel 6 | Signal status DI 5 Channel 5 | Signal status DI 4 Channel 4 | Signal status DI 3 Channel 3 | Signal status DI 2 Channel 2 | Signal status DI 1 Channel 1 | Wire break/short circuit DB/KS 8 Channel 8 | Wire break/short circuit DB/KS 7 Channel 7 | Wire break/short circuit DB/KS 6 Channel 6 | Wire break/short circuit DB/KS 5 Channel 5 | Wire break/short circuit DB/KS 4 Channel 4 | Wire break/short circuit DB/KS 3 Channel 3 | Wire break/short circuit DB/KS 2 Channel 2 | Wire break/short circuit DB/KS 1 Channel 1 |

| Output Process Image | | | | | | | | | | | | | | | |
|----------------------|-------|-------|-------|-------|-------|-------|-------|---------------------------|---------------------------|---------------------------|---------------------------|---------------------------|---------------------------|---------------------------|---------------------------|
| Output Byte D0 | | | | | | | | Output Byte D1 | | | | | | | |
| Bit 7 | Bit 6 | Bit 5 | Bit 4 | Bit 3 | Bit 2 | Bit 1 | Bit 0 | Bit 7 | Bit 6 | Bit 5 | Bit 4 | Bit 3 | Bit 2 | Bit 1 | Bit 0 |
| 0 | 0 | 0 | 0 | 0 | 0 | 0 | 0 | DI Off 8 Channel 8 | DI Off 7 Channel 7 | DI Off 6 Channel 6 | DI Off 5 Channel 5 | DI Off 4 Channel 4 | DI Off 3 Channel 3 | DI Off 2 Channel 2 | DI Off 1 Channel 1 |
| | | | | | | | | Channel ON 1: Channel OFF | Channel ON 1: Channel OFF | Channel ON 1: Channel OFF | Channel ON 1: Channel OFF | Channel ON 1: Channel OFF | Channel ON 1: Channel OFF | Channel ON 1: Channel OFF | Channel ON 1: Channel OFF |

13.1.1.8 16 Channel Digital Input Modules

750-1400, -1402, -1405, -1406, -1407

Table 123: 16 Channel Digital Input Modules

| Input Process Image | | | | | | | | | | | | | | | |
|---------------------------|---------------------------|---------------------------|---------------------------|---------------------------|---------------------------|---------------------------|-------------------------|-------------------------|-------------------------|-------------------------|-------------------------|-------------------------|-------------------------|-------------------------|-------------------------|
| Bit 15 | Bit 14 | Bit 13 | Bit 12 | Bit 11 | Bit 10 | Bit 9 | Bit 8 | Bit 7 | Bit 6 | Bit 5 | Bit 4 | Bit 3 | Bit 2 | Bit 1 | Bit 0 |
| Data bit DI 16 Channel 16 | Data bit DI 15 Channel 15 | Data bit DI 14 Channel 14 | Data bit DI 13 Channel 13 | Data bit DI 12 Channel 12 | Data bit DI 11 Channel 11 | Data bit DI 10 Channel 10 | Data bit DI 9 Channel 9 | Data bit DI 8 Channel 8 | Data bit DI 7 Channel 7 | Data bit DI 6 Channel 6 | Data bit DI 5 Channel 5 | Data bit DI 4 Channel 4 | Data bit DI 3 Channel 3 | Data bit DI 2 Channel 2 | Data bit DI 1 Channel 1 |

13.1.2 Digital Output Modules

Digital output modules use one bit of data per channel to control the output of the corresponding channel. These bits are mapped into the Output Process Image.

Some digital modules have an additional diagnostic bit per channel in the Input Process Image. The diagnostic bit is used for detecting faults that occur (e.g., wire breaks and/or short circuits). For modules with diagnostic bit is set, also the data bits have to be evaluated.

When analog output modules are also present in the node, the digital image data is always appended after the analog data in the Output Process Image, grouped into bytes.

13.1.2.1 1 Channel Digital Output Module with Input Process Data

750-523

The digital output modules deliver 1 bit via a process value Bit in the output process image, which is illustrated in the input process image. This status image shows "manual mode".

Table 124: 1 Channel Digital Output Module with Input Process Data

| Input Process Image | | | | | | | |
|---------------------|-------|-------|-------|-------|-------|----------|-------------------------------------|
| Bit 7 | Bit 6 | Bit 5 | Bit 4 | Bit 3 | Bit 2 | Bit 1 | Bit 0 |
| | | | | | | not used | Status bit "Manual Operation" |

| Output Process Image | | | | | | | |
|----------------------|-------|-------|-------|-------|-------|----------|-------------------------------|
| Bit 7 | Bit 6 | Bit 5 | Bit 4 | Bit 3 | Bit 2 | Bit 1 | Bit 0 |
| | | | | | | not used | controls DO 1 Channel 1 |

13.1.2.2 2 Channel Digital Output Modules

750-501, -502, -509, -512, -513, -514, -517, -535, (and all variations),
753-501, -502, -509, -512, -513, -514, -517

Table 125: 2 Channel Digital Output Modules

| Output Process Image | | | | | | | |
|----------------------|-------|-------|-------|-------|-------|-------------------------------|-------------------------------|
| Bit 7 | Bit 6 | Bit 5 | Bit 4 | Bit 3 | Bit 2 | Bit 1 | Bit 0 |
| | | | | | | controls DO 2 Channel 2 | controls DO 1 Channel 1 |

13.1.2.3 2 Channel Digital Input Modules with Diagnostics and Input Process Data

750-507 (-508), -522,
753-507

The digital output modules have a diagnostic bit for each output channel. When an output fault condition occurs (i.e., overload, short circuit, or broken wire), a diagnostic bit is set. The diagnostic data is mapped into the Input Process Image, while the output control bits are in the Output Process Image.

Table 126: 2 Channel Digital Input Modules with Diagnostics and Input Process Data

| Input Process Image | | | | | | | |
|---------------------|-------|-------|-------|-------|-------|------------------------------|------------------------------|
| Bit 7 | Bit 6 | Bit 5 | Bit 4 | Bit 3 | Bit 2 | Bit 1 | Bit 0 |
| | | | | | | Diagnostic bit S 2 Channel 2 | Diagnostic bit S 1 Channel 1 |

| Output Process Image | | | | | | | |
|----------------------|-------|-------|-------|-------|-------|-------------------------|-------------------------|
| Bit 7 | Bit 6 | Bit 5 | Bit 4 | Bit 3 | Bit 2 | Bit 1 | Bit 0 |
| | | | | | | controls DO 2 Channel 2 | controls DO 1 Channel 1 |

750-506,
753-506

The digital output module has 2-bits of diagnostic information for each output channel. The 2-bit diagnostic information can then be decoded to determine the exact fault condition of the module (i.e., overload, a short circuit, or a broken wire). The 4-bits of diagnostic data are mapped into the Input Process Image, while the output control bits are in the Output Process Image.

Table 127: 2 Channel Digital Input Modules with Diagnostics and Input Process Data 75x-506

| Input Process Image | | | | | | | |
|---------------------|-------|-------|-------|------------------------------|------------------------------|------------------------------|------------------------------|
| Bit 7 | Bit 6 | Bit 5 | Bit 4 | Bit 3 | Bit 2 | Bit 1 | Bit 0 |
| | | | | Diagnostic bit S 3 Channel 2 | Diagnostic bit S 2 Channel 2 | Diagnostic bit S 1 Channel 1 | Diagnostic bit S 0 Channel 1 |

Diagnostic bits S1/S0, S3/S2: = '00' standard mode
 Diagnostic bits S1/S0, S3/S2: = '01' no connected load/short circuit against +24 V
 Diagnostic bits S1/S0, S3/S2: = '10' Short circuit to ground/overload

| Output Process Image | | | | | | | |
|----------------------|-------|-------|-------|----------|----------|-------------------------|-------------------------|
| Bit 7 | Bit 6 | Bit 5 | Bit 4 | Bit 3 | Bit 2 | Bit 1 | Bit 0 |
| | | | | not used | not used | controls DO 2 Channel 2 | controls DO 1 Channel 1 |

13.1.2.4 4 Channel Digital Output Modules

750-504, -516, -519, -531,
753-504, -516, -531, -540

Table 128: 4 Channel Digital Output Modules

| Output Process Image | | | | | | | |
|----------------------|-------|-------|-------|-------------------------------|-------------------------------|-------------------------------|-------------------------------|
| Bit 7 | Bit 6 | Bit 5 | Bit 4 | Bit 3 | Bit 2 | Bit 1 | Bit 0 |
| | | | | controls DO 4 Channel 4 | controls DO 3 Channel 3 | controls DO 2 Channel 2 | controls DO 1 Channel 1 |

13.1.2.5 4 Channel Digital Output Modules with Diagnostics and Input Process Data

750-532

The digital output modules have a diagnostic bit for each output channel. When an output fault condition occurs (i.e., overload, short circuit, or broken wire), a diagnostic bit is set. The diagnostic data is mapped into the Input Process Image, while the output control bits are in the Output Process Image.

Table 129: 4 Channel Digital Output Modules with Diagnostics and Input Process Data

| Input Process Image | | | | | | | |
|---------------------|-------|-------|-------|---------------------------------------|---------------------------------------|---------------------------------------|---------------------------------------|
| Bit 7 | Bit 6 | Bit 5 | Bit 4 | Bit 3 | Bit 2 | Bit 1 | Bit 0 |
| | | | | Diagnostic bit S 4 Channel 4 | Diagnostic bit S 3 Channel 3 | Diagnostic bit S 2 Channel 2 | Diagnostic bit S 1 Channel 1 |

Diagnostic bit S = '0' no Error

Diagnostic bit S = '1' overload, short circuit, or broken wire

| Output Process Image | | | | | | | |
|----------------------|-------|-------|-------|-------------------------------|-------------------------------|-------------------------------|-------------------------------|
| Bit 7 | Bit 6 | Bit 5 | Bit 4 | Bit 3 | Bit 2 | Bit 1 | Bit 0 |
| | | | | controls DO 4 Channel 4 | controls DO 3 Channel 3 | controls DO 2 Channel 2 | controls DO 1 Channel 1 |

13.1.2.6 8 Channel Digital Output Module

750-530, -536, -1515, -1516
753-530, -534

Table 130: 8 Channel Digital Output Module

| Output Process Image | | | | | | | |
|-------------------------------|-------------------------------|-------------------------------|-------------------------------|-------------------------------|-------------------------------|-------------------------------|-------------------------------|
| Bit 7 | Bit 6 | Bit 5 | Bit 4 | Bit 3 | Bit 2 | Bit 1 | Bit 0 |
| controls DO 8 Channel 8 | controls DO 7 Channel 7 | controls DO 6 Channel 6 | controls DO 5 Channel 5 | controls DO 4 Channel 4 | controls DO 3 Channel 3 | controls DO 2 Channel 2 | controls DO 1 Channel 1 |

13.1.2.7 8 Channel Digital Output Modules with Diagnostics and Input Process Data

750-537

The digital output modules have a diagnostic bit for each output channel. When an output fault condition occurs (i.e., overload, short circuit, or broken wire), a diagnostic bit is set. The diagnostic data is mapped into the Input Process Image, while the output control bits are in the Output Process Image.

Table 131: 8 Channel Digital Output Modules with Diagnostics and Input Process Data

| Input Process Image | | | | | | | |
|---------------------|--------------------|--------------------|--------------------|--------------------|--------------------|--------------------|--------------------|
| Bit 7 | Bit 6 | Bit 5 | Bit 4 | Bit 3 | Bit 2 | Bit 1 | Bit 0 |
| Diagnostic bit S 8 | Diagnostic bit S 7 | Diagnostic bit S 6 | Diagnostic bit S 5 | Diagnostic bit S 4 | Diagnostic bit S 3 | Diagnostic bit S 2 | Diagnostic bit S 1 |
| Channel 8 | Channel 7 | Channel 6 | Channel 5 | Channel 4 | Channel 3 | Channel 2 | Channel 1 |

Diagnostic bit S = '0'

no Error

Diagnostic bit S = '1'

overload, short circuit, or broken wire

| Output Process Image | | | | | | | |
|----------------------|---------------|---------------|---------------|---------------|---------------|---------------|---------------|
| Bit 7 | Bit 6 | Bit 5 | Bit 4 | Bit 3 | Bit 2 | Bit 1 | Bit 0 |
| controls DO 8 | controls DO 7 | controls DO 6 | controls DO 5 | controls DO 4 | controls DO 3 | controls DO 2 | controls DO 1 |
| Channel 8 | Channel 7 | Channel 6 | Channel 5 | Channel 4 | Channel 3 | Channel 2 | Channel 1 |

13.1.2.8 16 Channel Digital Output Modules

750-1500, -1501, -1504, -1505

Table 132: 16 Channel Digital Output Modules

| Output Process Image | | | | | | | | | | | | | | | |
|----------------------|----------------|----------------|----------------|----------------|----------------|----------------|---------------|---------------|---------------|---------------|---------------|---------------|---------------|---------------|---------------|
| Bit 15 | Bit 14 | Bit 13 | Bit 12 | Bit 11 | Bit 10 | Bit 9 | Bit 8 | Bit 7 | Bit 6 | Bit 5 | Bit 4 | Bit 3 | Bit 2 | Bit 1 | Bit 0 |
| controls DO 16 | controls DO 15 | controls DO 14 | controls DO 13 | controls DO 12 | controls DO 11 | controls DO 10 | controls DO 9 | controls DO 8 | controls DO 7 | controls DO 6 | controls DO 5 | controls DO 4 | controls DO 3 | controls DO 2 | controls DO 1 |
| Channel 16 | Channel 15 | Channel 14 | Channel 13 | Channel 12 | Channel 11 | Channel 10 | Channel 9 | Channel 8 | Channel 7 | Channel 6 | Channel 5 | Channel 4 | Channel 3 | Channel 2 | Channel 1 |

13.1.2.9 8 Channel Digital Input/Output Modules

750-1502, -1506

Table 133: 8 Channel Digital Input/Output Modules

| Input Process Image | | | | | | | |
|-------------------------------|-------------------------------|-------------------------------|-------------------------------|-------------------------------|-------------------------------|-------------------------------|-------------------------------|
| Bit 7 | Bit 6 | Bit 5 | Bit 4 | Bit 3 | Bit 2 | Bit 1 | Bit 0 |
| Data bit DI 8 Channel 8 | Data bit DI 7 Channel 7 | Data bit DI 6 Channel 6 | Data bit DI 5 Channel 5 | Data bit DI 4 Channel 4 | Data bit DI 3 Channel 3 | Data bit DI 2 Channel 2 | Data bit DI 1 Channel 1 |

| Output Process Image | | | | | | | |
|-------------------------------|-------------------------------|-------------------------------|-------------------------------|-------------------------------|-------------------------------|-------------------------------|-------------------------------|
| Bit 7 | Bit 6 | Bit 5 | Bit 4 | Bit 3 | Bit 2 | Bit 1 | Bit 0 |
| controls DO 8 Channel 8 | controls DO 7 Channel 7 | controls DO 6 Channel 6 | controls DO 5 Channel 5 | controls DO 4 Channel 4 | controls DO 3 Channel 3 | controls DO 2 Channel 2 | controls DO 1 Channel 1 |

13.1.3 Analog Input Modules

The analog input modules provide 16-bit measured data and 8 control/status bits per channel.

The PFC200 controller only uses the 8 control/status bits internally for configuration/parameterization (e.g., via *WAGO-I/O-CHECK*).

Therefore, only the 16-bit measurement values for each channel are in Intel format and are mapped by word in the input process image for the PFC200 controller.

When digital input modules are also present in the node, the analog input data is always mapped into the Input Process Image in front of the digital data.

Information



Information on the structure of control and status bytes

For detailed information on the structure of a particular I/O module's control/status bytes, please refer to that module's manual. Manuals for each module can be found on the Internet at www.wago.com.

13.1.3.1 1 Channel Analog Input Modules

750-491, (and all variations)

Table 134: 1 Channel Analog Input Modules

| Input Process Image | | | |
|---------------------|------------------|----------|--------------------------|
| Offset | Byte Destination | | Description |
| | High Byte | Low Byte | |
| 0 | D1 | D0 | Measured Value U_D |
| 1 | D3 | D2 | Measured Value U_{ref} |

13.1.3.2 2 Channel Analog Input Modules

750-452, -454, -456, -461, -462, -465, -466, -467, -469, -472, -474, -475, 476, -477, -478, -479, -480, -481, -483, -485, -492, (and all variations),
753-452, -454, -456, -461, -465, -466, -467, -469, -472, -474, -475, 476, -477, 478, -479, -483, -492, (and all variations)

Table 135: 2 Channel Analog Input Modules

| Input Process Image | | | |
|---------------------|------------------|----------|--------------------------|
| Offset | Byte Destination | | Description |
| | High Byte | Low Byte | |
| 0 | D1 | D0 | Measured Value Channel 1 |
| 1 | D3 | D2 | Measured Value Channel 2 |

13.1.3.3 4 Channel Analog Input Modules

750-450, -453, -455, -457, -459, -460, -468, (and all variations),
753-453, -455, -457, -459

Table 136: 4 Channel Analog Input Modules

| Input Process Image | | | |
|----------------------------|-------------------------|-----------------|--------------------------|
| Offset | Byte Destination | | Description |
| | High Byte | Low Byte | |
| 0 | D1 | D0 | Measured Value Channel 1 |
| 1 | D3 | D2 | Measured Value Channel 2 |
| 2 | D5 | D4 | Measured Value Channel 3 |
| 3 | D7 | D6 | Measured Value Channel 4 |

13.1.3.4 3-Phase Power Measurement Module

750-493

The above Analog Input Modules have a total of 9 bytes of user data in both the Input and Output Process Image (6 bytes of data and 3 bytes of control/status). The following tables illustrate the Input and Output Process Image, which has a total of 6 words mapped into each image. Word alignment is applied.

Table 137: 3-Phase Power Measurement Module

| Input Process Image | | | |
|----------------------------|-------------------------|-----------------|--------------------|
| Offset | Byte Destination | | Description |
| | High Byte | Low Byte | |
| 0 | - | S0 | Status byte 0 |
| 1 | D1 | D0 | Input data word 1 |
| 2 | - | S1 | Status byte 1 |
| 3 | D3 | D2 | Input data word 2 |
| 4 | - | S2 | Status byte 2 |
| 5 | D5 | D4 | Input data word 3 |

| Output Process Image | | | |
|-----------------------------|-------------------------|-----------------|--------------------|
| Offset | Byte Destination | | Description |
| | High Byte | Low Byte | |
| 0 | - | C0 | Control byte 0 |
| 1 | D1 | D0 | Output data word 1 |
| 2 | - | C1 | Control byte 1 |
| 3 | D3 | D2 | Output data word 2 |
| 4 | - | C2 | Control byte 2 |
| 5 | D5 | D4 | Output data word 3 |

13.1.3.5 8 Channel Analog Input Modules

750-451

Table 138: 8 Channel Analog Input Modules

| Input Process Image | | | |
|----------------------------|-------------------------|-----------------|--------------------------|
| Offset | Byte Destination | | Description |
| | High Byte | Low Byte | |
| 0 | D1 | D0 | Measured Value Channel 1 |
| 1 | D3 | D2 | Measured Value Channel 2 |
| 2 | D5 | D4 | Measured Value Channel 3 |
| 3 | D7 | D6 | Measured Value Channel 4 |
| 4 | D9 | D8 | Measured Value Channel 5 |
| 5 | D11 | D10 | Measured Value Channel 6 |
| 6 | D13 | D12 | Measured Value Channel 7 |
| 7 | D15 | D14 | Measured Value Channel 8 |

13.1.4 Analog Output Modules

The analog output modules provide 16-bit output values and 8 control/status bits per channel.

The PFC200 controller only uses the 8 control/status bits internally for configuration/parameterization (e.g., via *WAGO-I/O-CHECK*).

Therefore, only the 16-bit measurement values for each channel are in Intel format and are mapped by word in the output process image for the PFC200 controller.

When digital output modules are also present in the node, the analog output data is always mapped into the Output Process Image in front of the digital data.



Information

Information on the structure of control and status bytes

For detailed information on the structure of a particular I/O module's control/status bytes, please refer to that module's manual. Manuals for each module can be found on the Internet at www.wago.com.

13.1.4.1 2 Channel Analog Output Modules

750-550, -552, -554, -556, -560, -562, 563, -585, (and all variations),
753-550, -552, -554, -556

Table 139: 2 Channel Analog Output Modules

| Output Process Image | | | |
|----------------------|------------------|----------|------------------------|
| Offset | Byte Destination | | Description |
| | High Byte | Low Byte | |
| 0 | D1 | D0 | Output Value Channel 1 |
| 1 | D3 | D2 | Output Value Channel 2 |

13.1.4.2 4 Channel Analog Output Modules

750-553, -555, -557, -559,
753-553, -555, -557, -559

Table 140: 4 Channel Analog Output Modules

| Output Process Image | | | |
|----------------------|------------------|----------|------------------------|
| Offset | Byte Destination | | Description |
| | High Byte | Low Byte | |
| 0 | D1 | D0 | Output Value Channel 1 |
| 1 | D3 | D2 | Output Value Channel 2 |
| 2 | D5 | D4 | Output Value Channel 3 |
| 3 | D7 | D6 | Output Value Channel 4 |

13.1.5 Specialty Modules

WAGO has a host of Specialty I/O modules that perform various functions. With individual modules beside the data bytes also the control/status byte is mapped in the process image.

The control/status byte is required for the bidirectional data exchange of the module with the higher-ranking control system. The control byte is transmitted from the control system to the module and the status byte from the module to the control system.

This allows, for example, setting of a counter with the control byte or displaying of overshooting or undershooting of the range with the status byte.

The control/status byte always is in the process image in the Low byte.

Information



Information to the structure of the Control/Status byte

For detailed information about the structure of a particular module's control/status byte, please refer to that module's manual. Manuals for each module can be found on the Internet under: www.wago.com.

13.1.5.1 Counter Modules

750-404, (and all variations except of /000-005),
753-404, (and variation /000-003)

The above Counter Modules have a total of 5 bytes of user data in both the Input and Output Process Image (4 bytes of counter data and 1 byte of control/status). The counter value is supplied as 32 bits. The following tables illustrate the Input and Output Process Image, which has a total of 3 words mapped into each image. Word alignment is applied.

Table 141: Counter Modules 750-404, (and all variations except of /000-005),
753-404, (and variation /000-003)

| Input Process Image | | | |
|---------------------|------------------|----------|---------------|
| Offset | Byte Destination | | Description |
| | High Byte | Low Byte | |
| 0 | - | S | Status byte |
| 1 | D1 | D0 | Counter value |
| 2 | D3 | D2 | |

| Output Process Image | | | |
|----------------------|------------------|----------|-----------------------|
| Offset | Byte Destination | | Description |
| | High Byte | Low Byte | |
| 0 | - | C | Control byte |
| 1 | D1 | D0 | Counter setting value |
| 2 | D3 | D2 | |

750-404/000-005

The above Counter Modules have a total of 5 bytes of user data in both the Input and Output Process Image (4 bytes of counter data and 1 byte of control/ status). The two counter values are supplied as 16 bits. The following tables illustrate the Input and Output Process Image, which has a total of 3 words mapped into each image. Word alignment is applied.

Table 142: Counter Modules 750-404/000-005

| Input Process Image | | | |
|----------------------------|------------------|----------|----------------------------|
| Offset | Byte Destination | | Description |
| | High Byte | Low Byte | |
| 0 | - | S | Status byte |
| 1 | D1 | D0 | Counter Value of Counter 1 |
| 2 | D3 | D2 | Counter Value of Counter 2 |

| Output Process Image | | | |
|-----------------------------|------------------|----------|------------------------------------|
| Offset | Byte Destination | | Description |
| | High Byte | Low Byte | |
| 0 | - | C | Control byte |
| 1 | D1 | D0 | Counter Setting Value of Counter 1 |
| 2 | D3 | D2 | Counter Setting Value of Counter 2 |

750-638,
753-638

The above Counter Modules have a total of 6 bytes of user data in both the Input and Output Process Image (4 bytes of counter data and 2 bytes of control/status). The two counter values are supplied as 16 bits. The following tables illustrate the Input and Output Process Image, which has a total of 4 words mapped into each image. Word alignment is applied.

Table 143: Counter Modules 750-638, 753-638

| Input Process Image | | | |
|----------------------------|------------------|----------|-----------------------------|
| Offset | Byte Destination | | Description |
| | High Byte | Low Byte | |
| 0 | - | S0 | Status byte von Counter 1 |
| 1 | D1 | D0 | Counter Value von Counter 1 |
| 2 | - | S1 | Status byte von Counter 2 |
| 3 | D3 | D2 | Counter Value von Counter 2 |

| Output Process Image | | | |
|-----------------------------|------------------|----------|-------------------------------------|
| Offset | Byte Destination | | Description |
| | High Byte | Low Byte | |
| 0 | - | C0 | Control byte von Counter 1 |
| 1 | D1 | D0 | Counter Setting Value von Counter 1 |
| 2 | - | C1 | Control byte von Counter 2 |
| 3 | D3 | D2 | Counter Setting Value von Counter 2 |

13.1.5.2 Pulse Width Modules

750-511, (and all variations /xxx-xxx)

The above Pulse Width modules have a total of 6 bytes of user data in both the Input and Output Process Image (4 bytes of channel data and 2 bytes of control/status). The two channel values are supplied as 16 bits. Each channel has its own control/status byte. The following table illustrates the Input and Output Process Image, which has a total of 4 words mapped into each image. Word alignment is applied.

Table 144: Pulse Width Modules 750-511, /xxx-xxx

| Input and Output Process | | | |
|--------------------------|------------------|----------|----------------------------------|
| Offset | Byte Destination | | Description |
| | High Byte | Low Byte | |
| 0 | - | C0/S0 | Control/Status byte of Channel 1 |
| 1 | D1 | D0 | Data Value of Channel 1 |
| 2 | - | C1/S1 | Control/Status byte of Channel 2 |
| 3 | D3 | D2 | Data Value of Channel 2 |

13.1.5.3 Serial Interface Modules with alternative Data Format

750-650, (and the variations /000-002, -004, -006, -009, -010, -011, -012, -013),
750-651, (and the variations /000-001, -002, -003),
750-653, (and the variations /000-002, -007),
753-650, -653

Note



The process image of the / 003-000-variants depends on the parameterized operating mode!

With the freely parameterizable variations /003 000 of the serial interface modules, the desired operation mode can be set. Dependent on it, the process image of these modules is then the same, as from the appropriate variation.

The above Serial Interface Modules with alternative data format have a total of 4 bytes of user data in both the Input and Output Process Image (3 bytes of serial data and 1 byte of control/status). The following table illustrates the Input and Output Process Image, which have a total of 2 words mapped into each image. Word alignment is applied.

Table 145: Serial Interface Modules with alternative Data Format

| Input and Output Process Image | | | | |
|--------------------------------|------------------|----------|-------------|---------------------|
| Offset | Byte Destination | | Description | |
| | High Byte | Low Byte | | |
| 0 | D0 | C/S | Data byte | Control/status byte |
| 1 | D2 | D1 | Data bytes | |

13.1.5.4 Serial Interface Modules with Standard Data Format

750-650/000-001, -014, -015, -016
750-653/000-001, -006

The above Serial Interface Modules with Standard Data Format have a total of 6 bytes of user data in both the Input and Output Process Image (5 bytes of serial data and 1 byte of control/status). The following table illustrates the Input and Output Process Image, which have a total of 3 words mapped into each image. Word alignment is applied.

Table 146: Serial Interface Modules with Standard Data Format

| Input and Output Process Image | | | | |
|--------------------------------|------------------|----------|-------------|---------------------|
| Offset | Byte Destination | | Description | |
| | High Byte | Low Byte | | |
| 0 | D0 | C/S | Data byte | Control/status byte |
| 1 | D2 | D1 | Data bytes | |
| 2 | D4 | D3 | | |

13.1.5.5 Data Exchange Module

750-654, (and the variation /000-001)

The Data Exchange modules have a total of 4 bytes of user data in both the Input and Output Process Image. The following tables illustrate the Input and Output Process Image, which has a total of 2 words mapped into each image. Word alignment is applied.

Table 147: Data Exchange Module

| Input and Output Process Image | | | |
|--------------------------------|------------------|----------|-------------|
| Offset | Byte Destination | | Description |
| | High Byte | Low Byte | |
| 0 | D1 | D0 | Data bytes |
| 1 | D3 | D2 | |

13.1.5.6 SSI Transmitter Interface Modules

750-630 (and all variations)



Note

The process image of the / 003-000-variants depends on the parameterized operating mode!

The operating mode of the configurable /003-000 I/O module versions can be set. Based on the operating mode, the process image of these I/O modules is then the same as that of the respective version.

The above SSI Transmitter Interface modules have a total of 4 bytes of user data in the Input Process Image, which has 2 words mapped into the image. Word alignment is applied.

Table 148: SSI Transmitter Interface Modules

| Input Process Image | | | |
|---------------------|------------------|----------|-------------|
| Offset | Byte Destination | | Description |
| | High Byte | Low Byte | |
| 0 | D1 | D0 | Data bytes |
| 1 | D3 | D2 | |

13.1.5.7 Incremental Encoder Interface Modules

750-631/000-004, -010, -011

The above Incremental Encoder Interface modules have 5 bytes of input data and 3 bytes of output data. The following tables illustrate the Input and Output Process Image, which have 4 words into each image. Word alignment is applied.

Table 149: Incremental Encoder Interface Modules 750-631/000-004, --010, -011

| Input Process Image | | | |
|---------------------|------------------|----------|------------------------|
| Offset | Byte Destination | | Description |
| | High Byte | Low Byte | |
| 0 | - | S | not used Status byte |
| 1 | D1 | D0 | Counter word |
| 2 | - | - | not used |
| 3 | D4 | D3 | Latch word |

| Output Process Image | | | |
|----------------------|------------------|----------|-------------------------|
| Offset | Byte Destination | | Description |
| | High Byte | Low Byte | |
| 0 | - | C | not used Control byte |
| 1 | D1 | D0 | Counter setting word |
| 2 | - | - | not used |
| 3 | - | - | not used |

750-634

The above Incremental Encoder Interface module has 5 bytes of input data (6 bytes in cycle duration measurement mode) and 3 bytes of output data. The following tables illustrate the Input and Output Process Image, which has 4 words mapped into each image. Word alignment is applied.

Table 150: Incremental Encoder Interface Modules 750-634

| Input Process Image | | | |
|---------------------|------------------|----------|----------------------------|
| Offset | Byte Destination | | Description |
| | High Byte | Low Byte | |
| 0 | - | S | not used Status byte |
| 1 | D1 | D0 | Counter word |
| 2 | - | (D2) *) | not used (Periodic time) |
| 3 | D4 | D3 | Latch word |

*) If cycle duration measurement mode is enabled in the control byte, the cycle duration is given as a 24-bit value that is stored in D2 together with D3/D4.

| Output Process Image | | | |
|----------------------|------------------|----------|-------------------------|
| Offset | Byte Destination | | Description |
| | High Byte | Low Byte | |
| 0 | - | C | not used Control byte |
| 1 | D1 | D0 | Counter setting word |
| 2 | - | - | not used |
| 3 | - | - | |

750-637

The above Incremental Encoder Interface Module has a total of 6 bytes of user data in both the Input and Output Process Image (4 bytes of encoder data and 2 bytes of control/status). The following table illustrates the Input and Output Process Image, which have 4 words mapped into each image. Word alignment is applied.

Table 151: Incremental Encoder Interface Modules 750-637

| Input and Output Process Image | | | |
|--------------------------------|------------------|----------|----------------------------------|
| Offset | Byte Destination | | Description |
| | High Byte | Low Byte | |
| 0 | - | C0/S0 | Control/Status byte of Channel 1 |
| 1 | D1 | D0 | Data Value of Channel 1 |
| 2 | - | C1/S1 | Control/Status byte of Channel 2 |
| 3 | D3 | D2 | Data Value of Channel 2 |

750-635,
753-635

The above Digital Pulse Interface module has a total of 4 bytes of user data in both the Input and Output Process Image (3 bytes of module data and 1 byte of control/status). The following table illustrates the Input and Output Process Image, which have 2 words mapped into each image. Word alignment is applied.

Table 152: Digital Pulse Interface Modules 750-635

| Input and Output Process Image | | | | |
|--------------------------------|------------------|----------|-------------|---------------------|
| Offset | Byte Destination | | Description | |
| | High Byte | Low Byte | | |
| 0 | D0 | C0/S0 | Data byte | Control/status byte |
| 1 | D2 | D1 | Data bytes | |

13.1.5.8 DC-Drive Controller

750-636

The DC-Drive Controller maps 6 bytes into both the input and output process image. The data sent and received are stored in up to 4 input and output bytes (D0 ... D3). Two control bytes (C0, C1) and two status bytes (S0/S1) are used to control the I/O module and the drive.

In addition to the position data in the input process image (D0 ... D3), it is possible to display extended status information (S2 ... S5). Then the three control bytes (C1 ... C3) and status bytes (S1 ... S3) are used to control the data flow.

Bit 3 of control byte C1 (C1.3) is used to switch between the process data and the extended status bytes in the input process image (Extended Info_ON). Bit 3 of status byte S1 (S1.3) is used to acknowledge the switching process.

Table 153: DC-Drive Controller 750-636

| Input Process Image | | | | |
|---------------------|------------------|--------------|--|--|
| Offset | Byte Destination | | Description | |
| | High Byte | Low Byte | | |
| 0 | S1 | S0 | Status byte S1 | Status byte S0 |
| 1 | D1*) / S3**) | D0*) / S2**) | Actual position*) / Extended status byte S3**) | Actual position (LSB) / Extended status byte S2**) |
| 2 | D3*) / S5**) | D2*) / S4**) | Actual position (MSB) / Extended status byte S3**) | Actual position*) / Extended status byte S4**) |

*) ExtendedInfo_ON = '0'.

***) ExtendedInfo_ON = '1'.

| Output Process Image | | | | |
|----------------------|------------------|----------|-------------------------|-------------------------|
| Offset | Byte Destination | | Description | |
| | High Byte | Low Byte | | |
| 0 | C1 | C0 | Control byte C1 | Control byte C0 |
| 1 | D1 | D0 | Setpoint position | Setpoint position (LSB) |
| 2 | D3 | D2 | Setpoint position (MSB) | Setpoint position |

13.1.5.9 Stepper Controller

750-670

The Stepper controller RS422 / 24 V / 20 mA 750-670 provides the fieldbus coupler 12 bytes input and output process image via 1 logical channel. The data to be sent and received are stored in up to 7 output bytes (D0 ... D6) and 7 input bytes (D0 ... D6), depending on the operating mode.

Output byte D0 and input byte D0 are reserved and have no function assigned.

One I/O module control and status byte (C0, S0) and 3 application control and status bytes (C1 ... C3, S1 ... S3) provide the control of the data flow.

Switching between the two process images is conducted through bit 5 in the control byte (C0 (C0.5)). Activation of the mailbox is acknowledged by bit 5 of the status byte S0 (S0.5).

Table 154: Stepper Controller RS 422 / 24 V / 20 mA 750-670

| Input Process Image | | | | |
|---------------------|------------------|----------|-----------------------------|------------------------------|
| Offset | Byte Destination | | Description | |
| | High Byte | Low Byte | | |
| 0 | reserved | S0 | reserved | Status byte S0 |
| 1 | D1 | D0 | Process data*) / Mailbox**) | |
| 2 | D3 | D2 | | |
| 3 | D5 | D4 | | |
| 4 | S3 | D6 | Status byte S3 | Process data*) / reserved**) |
| 5 | S1 | S2 | Status byte S1 | Status byte S2 |

*) Cyclic process image (Mailbox disabled)

***) Mailbox process image (Mailbox activated)

| Output Process Image | | | | |
|----------------------|------------------|----------|-----------------------------|------------------------------|
| Offset | Byte Destination | | Description | |
| | High Byte | Low Byte | | |
| 0 | reserved | C0 | reserved | Control byte C0 |
| 1 | D1 | D0 | Process data*) / Mailbox**) | |
| 2 | D3 | D2 | | |
| 3 | D5 | D4 | | |
| 4 | C3 | D6 | Control byte C3 | Process data*) / reserved**) |
| 5 | C1 | C2 | Control byte C1 | Control byte C2 |

*) Cyclic process image (Mailbox disabled)

***) Mailbox process image (Mailbox activated)

13.1.5.10 RTC Module

750-640

The RTC Module has a total of 6 bytes of user data in both the Input and Output Process Image (4 bytes of module data and 1 byte of control/status and 1 byte ID for command). The following table illustrates the Input and Output Process Image, which have 3 words mapped into each image. Word alignment is applied.

Table 155: RTC Module 750-640

| Input and Output Process Image | | | | |
|--------------------------------|------------------|----------|--------------|---------------------|
| Offset | Byte Destination | | Description | |
| | High Byte | Low Byte | | |
| 0 | ID | C/S | Command byte | Control/status byte |
| 1 | D1 | D0 | Data bytes | |
| 2 | D3 | D2 | | |

13.1.5.11 DALI/DSI Master Module

750-641

The DALI/DSI Master module has a total of 6 bytes of user data in both the Input and Output Process Image (5 bytes of module data and 1 byte of control/status). The following tables illustrate the Input and Output Process Image, which have 3 words mapped into each image. Word alignment is applied.

Table 156: DALI/DSI Master Module 750-641

| Input Process Image | | | | |
|---------------------|------------------|----------|---------------|--------------|
| Offset | Byte Destination | | Description | |
| | High Byte | Low Byte | | |
| 0 | D0 | S | DALI Response | Status byte |
| 1 | D2 | D1 | Message 3 | DALI Address |
| 2 | D4 | D3 | Message 1 | Message 2 |

| Output Process Image | | | | |
|----------------------|------------------|----------|------------------------------------|--------------|
| Offset | Byte Destination | | Description | |
| | High Byte | Low Byte | | |
| 0 | D0 | C | DALI command, DSI dimming value | Control byte |
| 1 | D2 | D1 | Parameter 2 | DALI Address |
| 2 | D4 | D3 | Command extension | Parameter 1 |

13.1.5.12 DALI Multi-Master Module

753-647

The DALI Multi-Master module occupies a total of 24 bytes in the input and output range of the process image.

The DALI Multi-Master module can be operated in "Easy" mode (default) and "Full" mode. "Easy" mode is used to transmit simply binary signals for lighting control. Configuration or programming via DALI master module is unnecessary in "Easy" mode.

Changes to individual bits of the process image are converted directly into DALI commands for a pre-configured DALI network. 22 bytes of the 24-byte process image can be used directly for switching of electronic ballasts (ECG), groups or scenes in "Easy" mode. Switching commands are transmitted via DALI and group addresses, where each DALI and each group address is represented by a 2-bit pair.

The structure of the process data is described in detail in the following tables.

Table 157: Overview of Input Process Image in the "Easy" Mode

| Input process image | | | |
|---------------------|------------------|-------------|--|
| Offset | Byte designation | | Note |
| | High byte | Low byte | |
| 0 | - | S | res. Status, activate broadcast Bit 0: 1-/2-button mode Bit 2: Broadcast status ON/OFF Bit 1,3-7: - |
| 1 | DA4...DA7 | DA0...DA3 | Bitpaar für DALI-Adresse DA0: Bit 1: Bit set = ON Bit not set = OFF Bit 2: Bit set = Error Bit not set = No error Bit pairs DA1 ... DA63 similar to DA0. |
| 2 | DA12...DA15 | DA8...DA11 | |
| 3 | DA20...DA23 | DA16...DA19 | |
| 4 | DA28...DA31 | DA24...DA27 | |
| 5 | DA36...DA39 | DA32...DA35 | |
| 6 | DA44...DA47 | DA40...DA43 | |
| 7 | DA52...DA55 | DA48...DA51 | |
| 8 | DA60...DA63 | DA56...DA59 | |
| 9 | GA4...GA7 | GA0...GA3 | Bit pair for DALI group address GA0: Bit 1: Bit set = ON Bit not set = OFF Bit 2: Bit set = Error Bit not set = No error Bit pairs GA1 ... GA15 similar to GA0. |
| 10 | GA12...GA15 | GA8...GA11 | |
| 11 | - | - | |

DA = DALI address
GA = Group address

Table 158: Overview of the Output Process Image in the "Easy" Mode

| Output process image | | | |
|----------------------|------------------|-------------|---|
| Offset | Byte designation | | Note |
| | High byte | Low byte | |
| 0 | - | S | res. Broadcast ON/OFF and activate: Bit 0: Broadcast ON Bit 1: Broadcast OFF Bit 2: Broadcast ON/OFF/dimming Bit 3: Broadcast short ON/OFF Bits 4 ... 7: reserved |
| 1 | DA4...DA7 | DA0...DA3 | Bit pair for DALI address DA0: Bit 1: short: DA switch ON long: dimming, brighter Bit 2: short: DA switch OFF long: dimming, darker Bit pairs DA1 ... DA63 similar to DA0. |
| 2 | DA12...DA15 | DA8...DA11 | |
| 3 | DA20...DA23 | DA16...DA19 | |
| 4 | DA28...DA31 | DA24...DA27 | |
| 5 | DA36...DA39 | DA32...DA35 | |
| 6 | DA44...DA47 | DA40...DA43 | |
| 7 | DA52...DA55 | DA48...DA51 | |
| 8 | DA60...DA63 | DA56...DA59 | |
| 9 | GA4...GA7 | GA0...GA3 | Bitpaar für DALI-Gruppenadresse GA0: Bit 1: short: GA switch ON long: dimming, brighter Bit 2: short: GA switch OFF long: dimming, darker Bit pairs GA1 ... GA15 similar to GA0. |
| 10 | GA12...GA15 | GA8...GA11 | |
| 11 | Bit 8...15 | Bit 0...7 | |

DA = DALI address
GA = Group address

13.1.5.13 LON[®] FTT Module

753-648

The process image of the LON[®] FTT module consists of a control/status byte and 23 bytes of bidirectional communication data that is processed by the WAGO-I/O-PRO function block "LON_01.lib". This function block is essential for the function of the LON[®] FTT module and provides a user interface on the control side.

13.1.5.14 EnOcean Radio Receiver

750-642

The EnOcean radio receiver has a total of 4 bytes of user data in both the Input and Output Process Image (3 bytes of module data and 1 byte of control/status). The following tables illustrate the Input and Output Process Image, which have 2 words mapped into each image. Word alignment is applied.

Table 159: EnOcean Radio Receiver 750-642

| Input Process Image | | | | |
|---------------------|------------------|----------|-------------|-------------|
| Offset | Byte Destination | | Description | |
| | High Byte | Low Byte | | |
| 0 | D0 | S | Data byte | Status byte |
| 1 | D2 | D1 | Data bytes | |

| Output Process Image | | | | |
|----------------------|------------------|----------|-------------|--------------|
| Offset | Byte Destination | | Description | |
| | High Byte | Low Byte | | |
| 0 | - | C | not used | Control byte |
| 1 | - | - | not used | |

13.1.5.15 MP Bus Master Module

750-643

The MP Bus Master Module has a total of 8 bytes of user data in both the Input and Output Process Image (6 bytes of module data and 2 bytes of control/status). The following table illustrates the Input and Output Process Image, which have 4 words mapped into each image. Word alignment is applied.

Table 160: MP Bus Master Module 750-643

| Input and Output Process Image | | | | |
|--------------------------------|------------------|----------|------------------------------|---------------------|
| Offset | Byte Destination | | Description | |
| | High Byte | Low Byte | | |
| 0 | C1/S1 | C0/S0 | extended Control/Status byte | Control/status byte |
| 1 | D1 | D0 | Data bytes | |
| 2 | D3 | D2 | | |
| 3 | D5 | D4 | | |

13.1.5.16 Bluetooth® RF-Transceiver

750-644

The size of the process image for the *Bluetooth*® module can be adjusted to 12, 24 or 48 bytes.

It consists of a control byte (input) or status byte (output); an empty byte; an overlay able mailbox with a size of 6, 12 or 18 bytes (mode 2); and the *Bluetooth*® process data with a size of 4 to 46 bytes.

Thus, each *Bluetooth*® module uses between 12 and 48 bytes in the process image. The sizes of the input and output process images are always the same.

The first byte contains the control/status byte; the second contains an empty byte.

Process data attach to this directly when the mailbox is hidden. When the mailbox is visible, the first 6, 12 or 18 bytes of process data are overlaid by the mailbox data, depending on their size. Bytes in the area behind the optionally visible mailbox contain basic process data. The internal structure of the *Bluetooth*® process data can be found in the documentation for the *Bluetooth*® 750-644 RF Transceiver.

The mailbox and the process image sizes are set with the startup tool WAGO-I/O-CHECK.

Table 161: Bluetooth® RF-Transceiver 750-644

| Input and Output Process Image | | | | |
|--------------------------------|------------------|----------|--|---------------------|
| Offset | Byte Destination | | Description | |
| | High Byte | Low Byte | | |
| 0 | - | C0/S0 | not used | Control/status byte |
| 1 | D1 | D0 | Mailbox (0, 3, 6 or 9 words) and Process data (2-23 words) | |
| 2 | D3 | D2 | | |
| 3 | D5 | D4 | | |
| ... | ... | ... | | |
| max. 23 | D45 | D44 | | |

13.1.5.17 Vibration Velocity/Bearing Condition Monitoring VIB I/O

750-645

The Vibration Velocity/Bearing Condition Monitoring VIB I/O has a total of 12 bytes of user data in both the Input and Output Process Image (8 bytes of module data and 4 bytes of control/status). The following table illustrates the Input and Output Process Image, which have 8 words mapped into each image. Word alignment is applied.

Table 162: Vibration Velocity/Bearing Condition Monitoring VIB I/O 750-645

| Input and Output Process Image | | | | |
|--------------------------------|------------------|----------|--|--|
| Offset | Byte Destination | | Description | |
| | High Byte | Low Byte | | |
| 0 | - | C0/S0 | not used | Control/status byte (log. Channel 1, Sensor input 1) |
| 1 | D1 | D0 | Data bytes (log. Channel 1, Sensor input 1) | |
| 2 | - | C1/S1 | not used | Control/status byte (log. Channel 2, Sensor input 2) |
| 3 | D3 | D2 | Data bytes (log. Channel 2, Sensor input 2) | |
| 4 | - | C2/S2 | not used | Control/status byte (log. Channel 3, Sensor input 1) |
| 5 | D5 | D4 | Data bytes (log. Channel 3, Sensor input 3) | |
| 6 | - | C3/S3 | not used | Control/status byte (log. Channel 4, Sensor input 2) |
| 7 | D7 | D6 | Data bytes (log. Channel 4, Sensor input 2) | |

13.1.5.18 KNX/EIB/TP1 Module

753-646

The KNX/TP1 module appears in router and device mode with a total of 24-byte user data within the input and output area of the process image, 20 data bytes and 2 control/status bytes. Even though the additional bytes S1 or C1 are transferred as data bytes, they are used as extended status and control bytes. The opcode is used for the read/write command of data and the triggering of specific functions of the KNX/EIB/TP1 module. Word-alignment is used to assign 12 words in the process image. Access to the process image is not possible in router mode. Telegrams can only be tunneled.

In device mode, access to the KNX data can only be performed via special function blocks of the IEC application. Configuration using the ETS engineering tool software is required for KNX.

Table 163: KNX/EIB/TP1 Module 753-646

| Input Process Image | | | | |
|---------------------|------------------|----------|----------------------|--------------|
| Offset | Byte Destination | | Description | |
| | High Byte | Low Byte | | |
| 0 | - | S0 | not used | Status byte |
| 1 | S1 | OP | extended Status byte | Opcode |
| 2 | D1 | D0 | Data byte 1 | Data byte 0 |
| 3 | D3 | D2 | Data byte 3 | Data byte 2 |
| 4 | D5 | D4 | Data byte 5 | Data byte 4 |
| 5 | D7 | D6 | Data byte 7 | Data byte 6 |
| 6 | D9 | D8 | Data byte 9 | Data byte 8 |
| 7 | D11 | D10 | Data byte 11 | Data byte 10 |
| 8 | D13 | D12 | Data byte 13 | Data byte 12 |
| 9 | D15 | D14 | Data byte 15 | Data byte 14 |
| 10 | D17 | D16 | Data byte 17 | Data byte 16 |
| 11 | D19 | D18 | Data byte 19 | Data byte 18 |

| Output Process Image | | | | |
|----------------------|------------------|----------|-----------------------|--------------|
| Offset | Byte Destination | | Description | |
| | High Byte | Low Byte | | |
| 0 | - | C0 | not used | Control byte |
| 1 | C1 | OP | extended Control byte | Opcode |
| 2 | D1 | D0 | Data byte 1 | Data byte 0 |
| 3 | D3 | D2 | Data byte 3 | Data byte 2 |
| 4 | D5 | D4 | Data byte 5 | Data byte 4 |
| 5 | D7 | D6 | Data byte 7 | Data byte 6 |
| 6 | D9 | D8 | Data byte 9 | Data byte 8 |
| 7 | D11 | D10 | Data byte 11 | Data byte 10 |
| 8 | D13 | D12 | Data byte 13 | Data byte 12 |
| 9 | D15 | D14 | Data byte 15 | Data byte 14 |
| 10 | D17 | D16 | Data byte 17 | Data byte 16 |
| 11 | D19 | D18 | Data byte 19 | Data byte 18 |

13.1.5.19 AS-interface Master Module

750-655

The length of the process image of the AS-interface master module can be set to fixed sizes of 12, 20, 24, 32, 40 or 48 bytes.

It consists of a control or status byte, a mailbox with a size of 0, 6, 10, 12 or 18 bytes and the AS-interface process data, which can range from 0 to 32 bytes.

The AS-interface master module has a total of 6 to maximally 24 words data in both the Input and Output Process Image. Word alignment is applied.

The first Input and output word, which is assigned to an AS-interface master module, contains the status / control byte and one empty byte.

Subsequently the mailbox data are mapped, when the mailbox is permanently superimposed (Mode 1).

In the operating mode with suppressible mailbox (Mode 2), the mailbox and the cyclical process data are mapped next.
The following words contain the remaining process data.

The mailbox and the process image sizes are set with the startup tool WAGO-I/O-CHECK.

Table 164: AS-interface Master Module 750-655

| Input and Output Process Image | | | | |
|---------------------------------------|-------------------------|-----------------|---|---------------------|
| Offset | Byte Destination | | Description | |
| | High Byte | Low Byte | | |
| 0 | - | C0/S0 | not used | Control/status byte |
| 1 | D1 | D0 | Mailbox (0, 3, 5, 6 or 9 words)/ Process data (0-16 words) | |
| 2 | D3 | D2 | | |
| 3 | D5 | D4 | | |
| ... | ... | ... | | |
| max. 23 | D45 | D44 | | |

13.1.6 System Modules

13.1.6.1 System Modules with Diagnostics

750-610, -611

The modules provide 2 bits of diagnostics in the Input Process Image for monitoring of the internal power supply.

Table 165: System Modules with Diagnostics 750-610, -611

| Input Process Image | | | | | | | |
|---------------------|-------|-------|-------|-------|-------|-------------------------|-------------------------|
| Bit 7 | Bit 6 | Bit 5 | Bit 4 | Bit 3 | Bit 2 | Bit 1 | Bit 0 |
| | | | | | | Diagnostic bit S 2 Fuse | Diagnostic bit S 1 Fuse |

13.1.6.2 Binary Space Module

750-622

The Binary Space Modules behave alternatively like 2 channel digital input modules or output modules and seize depending upon the selected settings 1, 2, 3 or 4 bits per channel. According to this, 2, 4, 6 or 8 bits are occupied then either in the process input or the process output image.

Table 166: Binary Space Module 750-622 (with Behavior Like 2 Channel Digital Input)

| Input and Output Process Image | | | | | | | |
|--------------------------------|-----------------|-----------------|-----------------|-----------------|-----------------|---------------|---------------|
| Bit 7 | Bit 6 | Bit 5 | Bit 4 | Bit 3 | Bit 2 | Bit 1 | Bit 0 |
| (Data bit DI 8) | (Data bit DI 7) | (Data bit DI 6) | (Data bit DI 5) | (Data bit DI 4) | (Data bit DI 3) | Data bit DI 2 | Data bit DI 1 |

13.2 CODESYS Libraries

Additional functions for the controller 750-8202 are provided using libraries.

13.2.1 General Libraries

This section contains general CODESYS libraries supported by the controller 750-8202.

13.2.1.1 CODESYS System Libraries

All of the functions of the CODESYS system libraries listed below are supported.

Table 167: CODESYS System Libraries

| Library | Function | C/IEC 61131 |
|------------------------|--|-----------------|
| Analyzation.lib | Analysis of boolean expressions | C and IEC 61131 |
| AnalyzationNew.lib | Analysis of boolean expressions | C and IEC 61131 |
| Iecsfc.lib | Provision of implicit variables in the SFC (sequential function chart) | IEC 61131 |
| NetVarUdp_LIB_V23.lib | Implementation for network variables | IEC 61131 |
| Standard.LIB | Offers various standard functions | C |
| SysLibAlarmTrend.lib | Supports alarm and trend tasks | IEC 61131 |
| SysLibCallback.lib | For installing call-back handlers and event handlers | C |
| SysLibDir.lib | For accessing directories | C |
| SysLibDirect.lib | Access to variables using indices | C |
| SysLibEvent.lib | Handling of events in the system | C |
| SysLibFileStream.lib | File handling using ANSI-C functions | C |
| SysLibGetAddress.lib | Returns addresses and the size of memory segments | C |
| SysLibIecTasks.lib | Administration of IEC tasks | C |
| SysLibMem.lib | Memory administration | C |
| SysLibPlcCtrl.lib | Control of the PLC from outside the PLC program | C |
| SysLibProjectInfo.lib | Reading out of information about the CODESYS project | C |
| SysLibSem.lib | Handling of semaphores | C |
| SysLibSockets.lib | Socket handling | C |
| SysLibSocketsAsync.lib | Socket handling, asynchronous | C |
| SysLibStr.lib | String functions | C |
| SysLibTasks.lib | Administration of tasks | C |
| SysLibTime.lib | Administration of real-time clock | C |
| SysLibVisu.lib | Dynamic visualization | C |

Table 167: CODESYS System Libraries

| Library | Function | C/IEC 61131 |
|------------------|---|-------------|
| SysTaskInfo.lib | Evaluation of task information in the Online mode | IEC 61131 |
| Util.lib | Various logical operations | IEC 61131 |
| Util_no_Real.lib | Various logical operations | IEC 61131 |

Additional information about the libraries is given in the online Help function for CODESYS-IDE.

13.2.1.2 SysLibCom.lib

The controller 750-8202 supports the following function blocks of the “SysLibCom.lib” library:

- SysComClose
- SysComGetVersion2300
- SysComOpen
- SysComRead
- SysComSetSettings
- SysComSetSettingsEx
- SysComWrite

Note



Observe restrictions on the settings for stop bits!

The setting “1.5 stop bits” is not supported by controller 750-8202.

Additional information about this is given in the online Help function for CODESYS-IDE.

13.2.1.3 SysLibFile.lib

The controller 750-8202 supports the following function blocks of the “SysLibCom.lib” library:

- SysFileClose
- SysFileCopy
- SysFileDelete
- SysFileEOF
- SysFileGetPos
- SysFileGetSize
- SysFileGetTime
- SysFileOpen
- SysFileRead
- SysFileRename
- SysFileSetPos
- SysFileWrite

Note



Ensure that files are saved!

Files are not reliably saved on the data medium until you call up the “SysFileClose” function block!

Additional information about this is given in the online Help function for CODESYS-IDE.

13.2.1.4 SysLibFileAsync.lib

The controller 750-8202 supports the following function blocks of the “SysLibCom.lib” library:

- SysFileCloseAsync
- SysFileCopyAsync
- SysFileDeleteAsync
- SysFileEOFAsync
- SysFileGetPosAsync
- SysFileGetSizeAsync
- SysFileGetTimeAsync
- SysFileOpenAsync
- SysFileReadAsync
- SysFileRenameAsync
- SysFileSetPosAsync
- SysFileWriteAsync

Note



Ensure that files are saved!

Files are not reliably saved to the data medium until you call up the “SysFileCloseAsync” function block.

Additional information about this is given in the online Help function for CODESYS-IDE.

13.2.1.5 SysLibRtc.lib

The controller 750-8202 supports the following function blocks of the “SysLibRtc.lib” library:

- SysRtcGetHourMode
- SysRtcGetTime
- SysRtcSetTime

Additional information about this is given in the online Help function for CODESYS-IDE.

13.2.1.6 BusDiag.lib

The controller 750-8202 supports the following function blocks of the “BusDiag.lib” library:

- DiagGetBusState
- DiagGetState

The document containing a description of this library and the function blocks it includes is available for download on the Internet at www.wago.com.

The values for the input variables “DEVICE NUMBER” of the “DiagGetBusState” and “DiagGetState” functions are based on the particular device and bus system and are as follows for the controller 750-8202:

Table 168: Input Variable “DEVICE NUMBER”

| Bus System | Value |
|-------------------|-------|
| Internal data bus | 0 |
| MODBUS | 1 |

13.2.1.7 mod_com.lib

The controller 750-8202 supports the following function blocks of the “mod_com.lib” library:

- ADD_PI_INFORMATION
- CRC16
- FBUS_ERROR_INFORMATION
- GET_DIGITAL_INPUT_OFFSET
- GET_DIGITAL_OUTPUT_OFFSET
- KBUS_ERROR_INFORMATION
- MOD_COM_VERSION
- PI_INFORMATION
- SET_DIGITAL_INPUT_OFFSET
- SET_DIGITAL_OUTPUT_OFFSET
- SLAVE_ADDRESS

The document containing a description of this library and the function blocks it includes is available for download on the Internet at www.wago.com.

13.2.1.8 SerComm.lib

The controller 750-8202 supports the following function blocks of the “SerComm.lib” library:

- SERCOMM
- SERCOMM_VERSION

The document containing a description of this library and the function blocks it includes is available for download on the Internet at www.wago.com.

13.2.1.9 WagoConfigToolLIB.lib

The following table shows call-ups that allow you to configure and parameterize the controller from the PLC program or Linux[®] via the “ConfigToolFB” function block (see parameter “stCallString”). In addition to WBM and the CBM, this is another variant to configure the controller for operational requirements.

The configuration directory for this under Linux[®] is: `/etc/config-tools/`

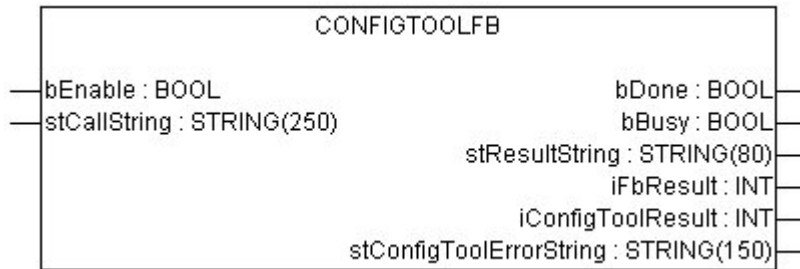

Figure 99: Graphical Representation of the “ConfigToolFB” Function Block

Table 169: Description of the Configuration Scripts for “Information”

| Parameters | Status | Call-Up | Output/Input | Effective |
|--|--------|--|--|-------------|
| Controller Details: Identifies various information about the controller | | | | |
| Product Description | read | get_coupler_details product-description | Product description | Immediately |
| Order Number | read | get_coupler_details order-number | Item number of the controller | Immediately |
| Firmware Revision | read | get_coupler_details firmware-revision | Firmware version of the controller | Immediately |
| Licence Information | read | get_coupler_details license-information | CODESYS license details | Immediately |
| Network Details X1: Identifies the parameters currently used for the ETHERNET interface X1/X2 in “switched” mode or for the ETHERNET interface X1 in “separated” mode | | | | |
| State | read | get_actual_eth_config X1 state | Status of the interface. Possible return values: - enabled - disabled | Immediately |
| Mac Address | read | get_actual_eth_config X1 mac-address | Display of the MAC address | Immediately |
| IP Address | read | get_actual_eth_config X1 ip-address | Display of current IP address | Immediately |
| Subnet Mask | read | get_actual_eth_config X1 subnet-mask | Display of the current subnet mask | Immediately |
| Network Details X2: Identifies the parameters currently used for the ETHERNET interface X2 in “separated” mode | | | | |
| See “Network Details X1”. When calling these up, replace “X1” with “X2” (in “separated” mode only). | | | | |

Table 170: Description of the Configuration Scripts for “CODESYS”

| Parameters | Status | Call-Up | Output/Input | Effective |
|------------------------------|--------|---|--|-------------|
| Information | | | | |
| CODESYS Web-Server Version | read | get_coupler_details codesys-Web-Server-version | CODESYS Web server version | Immediately |
| Project Details | | | | |
| Date | read | get_rts_info project date | Display of the project information specified in CODESYS (Menu > Project > Project Information) | Immediately |
| Title | read | get_rts_info project title | | Immediately |
| Version | read | get_rts_info project version | | Immediately |
| Author | read | get_rts_info project author | | Immediately |
| Description | read | get_rts_info project description | | Immediately |
| CODESYS State | | | | |
| State | read | get_rts_info state | Display of the CODESYS status (RUN or STOP) | Immediately |
| Boot Project Location | | | | |
| Boot Project Location | read | get_rts3scfg_value PLC Files | Reading of the storage location of the boot project Possible return values: - HOME:// - CARD:// | Immediately |
| | write | change_rts_config area=PLC Files=<value> | Change the storage location for the boot project. Possible entries for <Value>: - HOME:// - CARD:// | |

Table 171: Description of the Configuration Scripts for “Networking - Host-/Domain-Name”

| Parameters | Status | Call-Up | Output/Input | Effective |
|--------------------|--------|---|--|---------------|
| Host Name | | | | |
| Host Name | read | get_coupler_details hostname | Display of the host name. The return value is blank when /etc/hostname is empty. For details see the parameter “Actual Hostname”. | Immediately |
| | write | change_hostname hostname=<String> | Changing the host name. Input a host name for <String>. | After restart |
| Actual Hostname | read | get_coupler_details actual-hostname | The actual host name (if /etc/hostname is empty, a unique host name is generated from the MAC address) | Immediately |
| Domain Name | | | | |
| Domain Name | read | get_coupler_details domain-name | Display of domain name | Immediately |
| | write | edit_dns_server domain-name=<String> | Change the domain name. Enter the domain name for <String>. | |

Table 172: Description of the Configuration Scripts for “Networking - TCP/IP”

| Parameters | Status | Call-Up | Output/Input | Effective |
|---|--------|---|--|-------------|
| IP Address X1: Identifies the parameters currently used for the ETHERNET interface X1/X2 in “switched” mode or for the ETHERNET interface X1 in “separated” mode | | | | |
| Type of IP address configuration | read | get_eth_config X1 config-type | Method by which the interface receives its IP address: Possible return values: - static (set statically) - dhcp (per DHC) - bootp (per BootP) | Immediately |
| | write | config_interfaces interface=X1 config-type=<value> state=enabled | Activate the method by which the interface receives its IP address. Possible entries for <Value>: - static (set statically) - dhcp (per DHC) - bootp (per BootP) | |
| IP address | read | get_eth_config X1 ip-address | Address set for using a static IP address (static IP). | Immediately |
| | write | config_interfaces interface=X1 ip-address=<value> | Change IP address for static IP. <Value> must have an IP address with the format “Number.Number.Number.Number”. | |
| Subnet Mask | read | get_eth_config X1 subnet-mask | Subnet mask set for using a static IP address (Static IP). | Immediately |
| | write | config_interfaces interface=X1 subnet-mask=<value> | Change subnet mask for static IP. <Value> must have an IP address with the format “Number.Number.Number.Number”. | |
| IP Address X2: Identifies the parameters currently used for the ETHERNET interface X2 in “separated” mode | | | | |
| See “IP Address X1”. When calling these up, replace “X1” with “X2” (in “separated” mode only). | | | | |

Table 172: Description of the Configuration Scripts for “Networking - TCP/IP”

| Parameters | Status | Call-Up | Output/Input | Effective |
|------------------------|--|--|--|-------------|
| Default Gateway | | | | |
| Default Gateway | read | get_coupler_details default-gateway | Display of the standard gateway address. | Immediately |
| | read | get_eth_config X1 default-gateway | Display of the standard gateway address. Use of “X2” leads to the same result because the value is always written for both interfaces at the same time. | Immediately |
| | write | config_default_gateway interface=<value> default-gateway- value=<value> | Select the interface you want to use as the standard gateway. Possible entries for interface: - X1 - X2 - none (no standard gateway selected) Default-gateway-value is an IP address with the format “Number.Number.Number.Number”. | Immediately |
| DNS server | | | | |
| DNS Server 1 | read | get_dns_server 1 | DNS server address with the consecutive number 1. | Immediately |
| | write/ change | edit_dns_server dns-server-nr=1 change=change dns-server- name=<value> | Set the address of the DNS server with 1 as the consecutive number. <Value> is an IP address with the format “Number.Number.Number.Number”. | |
| | write/ delete | edit_dns_server dns-server-nr=1 delete=delete | Delete the DNS server with the consecutive number 1. | |
| DNS Server 2 ... n | See “DNS Server 1”. Change the server number each time you call this up (ascending order). | | | Immediately |
| Add DNS server | write | edit_dns_server add=add dns-server- name=<value> | Add additional DNS addresses here. <Value> is an IP address with the format “Number.Number.Number.Number”. | Immediately |

Table 173: Description of the Configuration Scripts for “Networking - ETHERNET”

| Parameters | Status | Call-Up | Output/Input | Effective |
|--|--------|---|---|-------------|
| Switch Configuration | | | | |
| Interface Mode | read | get_dsa_mode | Query the switch configuration: Possible return values: - 0 = „switched“ mode - 1 = „separated“ mode | Immediately |
| | write | set_dsa_mode -v <value> | Set the switch configuration: Possible entries for <value>: - 0 = „switched“ mode - 1 = „separated“ mode | |
| Interface X1 | | | | |
| Port State | read | get_eth_config X1 state | Query the port state: Possible return values: - enabled - disabled | Immediately |
| | write | config_ethernet port=X1 state=enabled | Activate port: enabled | |
| | | config_ethernet port=X1 state=disabled | Deactivate port: disabled | |
| Autonegotiation | read | get_eth_config X1 autoneg | Query the status of the autonegotiation function: Possible return values: - on - off | Immediately |
| | write | config_ethernet port=X1 autoneg=on | Activate the autonegotiation function: on | |
| | | config_ethernet port=X1 autoneg=off speed=<value> duplex=<value> | Deactivate the autonegotiation function: off Note: You must also indicate the speed and duplex value when you deactivate the autonegotiation function. Possible entries for speed: - 10M - 100M Possible entries for duplex: - half - full | |
| Speed and Duplex Settings | read | get_eth_config X1 speed | Display of ETHERNET speed | Immediately |
| | read | get_eth_config X1 duplex | Display of the Duplex mode | |
| | write | config_ethernet port=X1 autoneg=off speed=<value> duplex=<value> | Change the ETHERNET speed and the Duplex mode. Possible entries for speed: - 10M - 100M Possible entries for duplex: - half - full | |
| Interface X2 | | | | |
| See “Interface X1”. When calling these up, replace “X1” with “X2”. | | | | |

Table 174: Description of the Configuration Scripts for “CODESYS”

| Parameters | Status | Call-Up | Output/Input | Effective |
|---|--------|--|---|--|
| Transmission Mode X1 | | | | |
| Autonegotiation | read | get_eth_config X1 autoneg | Query the status of the autonegotiation function. Possible return values: - on - off | Immediately |
| | write | config_ethernet port=X1 autoneg=on | Activate the autonegotiation function: on | |
| | | | config_ethernet port=X1 autoneg=off speed- duplex=<value> | Deactivate the autonegotiation function: off Note: You must also indicate the speed and duplex value when you deactivate the autonegotiation function. Possible entries for <Value>: - 10-half - 10-full - 100-half - 100-full |
| Speed and Duplex Settings | read | get_eth_config X1 speed | Display of ETHERNET speed | Immediately |
| | read | get_eth_config X1 duplex | Display of Duplex mode | |
| | write | config_ethernet port=X1 autoneg=off speed-duplex=<value> | Change the ETHERNET speed and the Duplex mode. Possible entries for <Value>: - 10-half - 10-full - 100-half - 100-full | |
| Transmission Mode X2 | | | | |
| See “Transmission Mode X1”. When calling, replace “X1” with “X2”. | | | | |

Table 175: Description of the Configuration Scripts for “NTP”

| Parameters | Status | Call-Up | Output/Input | Effective |
|---------------------------|--------|------------------------------------|--|-------------|
| Configuration Data | | | | |
| State | read | get_ntp_config state | Query the status of the NTP server. Possible return values: - enabled - disabled | Immediately |
| | write | config_sntp state=<value> | Possible entries for <Value>: - enabled - disabled | |
| Port | read | get_ntp_config port | Port number of the NTP server | Immediately |
| | write | config_sntp port=<value> | Enter the port number for <Value>. | |
| Time Server | read | get_ntp_config time-server | Query the IP address of the Time server. | Immediately |
| | write | config_sntp time-server=<value> | Enter the IP address of the Time server. The <value> can contain an IP address in the format “Number.Number.Number.Number” or a domain name as a string. | |
| Update Time (seconds) | read | get_ntp_config update-time | Query the polling cycle of the time server. | Immediately |
| | write | config_sntp update-time=<value> | Specify the time-server's query cycle (in s) for <value>. | |

Table 176: Description of the Configuration Scripts for “Clock”

| Parameters | Status | Call-Up | Output/Input | Effective |
|-----------------------|--------|---|--|-------------|
| Clock | | | | |
| Time and Date | | | | |
| Date on device, local | read | get_clock_data date-local | Local time and date | Immediately |
| | write | config_clock type=local date=<Datum> | Change date. The format for <date> is: DD.MM.YYYY | |
| Time on device, UTC | read | get_clock_data time-utc | Time/UTC | Immediately |
| | write | config_clock type=utc time=<Time> | Change time, based on UTC time. The format for <time> is: hh:mm:ss xx | |
| Time on device, local | read | get_clock_data time-local | Time/local time | Immediately |
| | write | config_clock type=local time=<Time> | Change time, based on local time. The format for <time> is: hh:mm:ss xx | |
| 12-Hour-Format | read | get_clock_data display-mode | Presentation format either as 12 or 24-hour format: Possible return values: - 12-hour-format - 24-hour-format | Immediately |
| | write | config_clock_ display_mode display-mode=<value> | Set the presentation format for the time. Possible entries for <Value>: - 12-hour-format - 24-hour-format | |
| Time Zone | | | | |
| TZ-String | read | get_clock_data tz-string | Currently set time zone – original TZ string as stored in the operating system. | Immediately |
| | write | config_timezone tz-string=<String> | Change TZ string directly. Example of <String>: CET-1CEST, M3.5.0/2,M10.5.0/3 | |

Table 177: Description of the Configuration Scripts for “Administration”

| Parameters | Status | Call-Up | Output/Input | Effective |
|--|--------|------------------------------------|--|-------------|
| Administration | | | | |
| Configuration of Serial Interface | | | | |
| Configuration of serial interface | read | get_coupler_details RS232-owner | User of the serial interface. Possible return values: - Linux® - None | immediately |
| | write | config_RS232 owner=<value> | User of the serial interface. Possible entries for <Value>: - Linux® - None | |
| Reboot Controller | | | | |
| - | write | start_reboot | Restart the controller. | immediately |

Table 178: Description of Configuration Scripts for “Package Server”

| Parameters | Status | Call-Up | Output/Input | Valid |
|-----------------------------|--------|---|--|------------|
| Firmware Update | | | | |
| Medium for active partition | read | get_filesystem_data active-partition-medium | Specifies the medium for the active partition (memory card, internal flash). | Right away |
| Create firmware backup | write | firmware_backup package-settings=<Value1> package-codesys=<Value2> package-system=<Value3> device-medium=<Value4> auto-update=<Value5> | Generates a backup of the selected packet on the specified medium. Parameter: <Value1> = 1, if “Settings” packet is to be selected. <Value2> = 1, if the “CODESYS Project” packet is to be selected. <Value3> = 1, if the “System” packet is to be selected. <Value4> = Target medium for saving the backup. (memory card, internal flash) <Value5> = 1, if Auto Update is to be activated. Parameters, which are not to be set (1) can either be set to 0 or omitted completely. | Right away |

Table 179: Description of Configuration Scripts for “Ports and Services”

| Parameters | Status | Call-Up | Output/Input | Valid |
|---------------|--------|---|---|------------|
| Port | | | | |
| Telnet | | | | |
| Telnet Port | read | get_port_state telnet | Read the status of the Telnet server. Possible return values: - enabled - disabled | Right away |
| | write | config_port port=telnet state=<Value> | Possible entries for <Value>: - enabled - disabled | |
| FTP | | | | |
| FTP Port | read | config_ssl ftp-status | Read the status of the FTP server. Possible return values: - enabled - disabled | Right away |
| | write | config_port port=ftp state=<Value> | Possible entries for <Value>: - enabled - disabled | |
| FTPS | | | | |
| FTPS Port | read | Config_ssl ftps-status | Read the status of the FTPS port. Possible return values: - enabled - disabled | Right away |
| | write | config_port port=ftps state=<Value> | Activate/Deactivate FTPS. Possible entries for <Value>: - enabled - disabled | |

Table 179: Description of Configuration Scripts for “Ports and Services”

| Parameters | Status | Call-Up | Output/Input | Valid |
|--------------|--------|--------------------------------------|--|------------|
| HTTP | | | | |
| HTTP Port | read | Config_ssl http-status | Read the status of the HTTP port. Possible return values: - enabled - disabled | Right away |
| | write | config_port port=http state=<Value> | Activate/Deactivate HTTP. Possible entries for <Value>: - enabled - disabled | |
| HTTPS | | | | |
| HTTPS Port | read | Config_ssl https-status | Read the status of the HTTPS port. Possible return values: - enabled - disabled | Right away |
| | write | config_port port=https state=<Value> | Activate/Deactivate HTTPS. Possible entries for <Value>: - enabled - disabled | |

Table 179: Description of Configuration Scripts for “Ports and Services”

| Parameters | Status | Call-Up | Output/Input | Valid |
|-------------|---|---|---|---------------|
| SSH | | | | |
| SSH | read | get_ssh_config state | Read the status of the SSH port. Possible return values: - enabled - disabled | Right away |
| | read | get_ssh_config root-access-state | Indicates whether logon as root is permitted. Possible return values: - enabled - disabled | |
| | read | get_ssh_config password-request-state | Indicates whether authentication by password (instead of PKI key files) is permitted. Possible return values: - enabled - disabled | |
| | read | get_ssh_config port-number | Specifies the SSH port | |
| | write | config_ssh state=<Value> | Activate/Deactivate SSH service. Possible entries for <Value>: - enabled - disabled | |
| | write | config_ssh port-number=<Value> | Set the SSH port | |
| | write | config_ssh root-access-state-value=<Value> | Permit/Prohibit logon as root. Possible entries for <Value>: - enabled - disabled | |
| write | config_ssh password-request-state-value=<Value> | Permit/Prohibit authentication by password. Possible entries for <Value>: - enabled - disabled | | |
| TFTP | | | | |
| TFTP | read | get_tftp_config state | Read the status of the TFTP port. Possible return values: - enabled - disabled | Right away |
| | read | get_tftp_config download-dir | Read the TFTP main directory. | |
| | write | config_tftp state=<Value> | Activate/Deactivate TFTP port. Possible entries for <Value>: - enabled - disabled | |
| | write | config_tftp download-dir=<Value> | Set the TFTP main directory. | |

Table 179: Description of Configuration Scripts for “Ports and Services”

| Parameters | Status | Call-Up | Output/Input | Valid |
|---|--------|--|--|---------------|
| CODESYS | | | | |
| CODESYS Webserver Port | read | get_port_state codesys-webserver | Read status of the CODESYS Web server. Possible return values: - enabled - disabled | Right away |
| | write | config_port port=codesys-webserver state=<Value> | Enable/disable the CODESYS Web server. Possible entries for <Value>: - enabled - disabled | |
| CODESYS Port | read | get_rts3scfg_value PLC DisableTcpIp Programming | Query the status of the value for “DisableTcpIpProgramming” in the CODESYS configuration. Possible return values: - YES: CODESYS port not being used. - NO: CODESYS port in use | Right away |
| | write | change_rts_config area=PLC disable- tcpip=<Value> | Possible entries for <Value>: - YES: CODESYS port not being used. - NO: CODESYS port in use. | |
| CODESYS Port Number | read | get_rts3scfg_value PLC TcpIpPort | Value set in the CODESYS configuration for the TCP/IP port. | Right away |
| | write | change_rts_config area=PLC TcpIpPort=<Value> | Change the CODESYS port number. Enter the TCP/IP port number for <Value>. | |
| CODESYS Authentication | read | get_rts3scfg_value PASSWORD USEPWD | Read the status of the CODESYS access password query. Possible return values: - 1 - 0 | Right away |
| | write | change_rts_config area=PASSWORD USEPWD=<Value> | Activate/Deactivate CODESYS access password query. Possible entries for <Value>: - 1 - 0 | |
| Change CODESYS Authentication Password | write | config_linux_user user=admin new- password=<Value> confirm- password=<Value> | Change the CODESYS access password | Right away |

Table 180: Description of configuration scripts for “SNMP”

| Parameters | Status | Call-Up | Output/Input | Valid |
|--|--------|--|--|---------------|
| General SNMP information parameters | | | | |
| Name of device | read | get_snmp_data device-name | Specifies the SNMP parameter “sysName”. | Right away |
| | write | config_snmp device-name=<Value> | Change the SNMP parameter “sysName” (<Value> = string). * | After restart |
| Description | read | get_snmp_data description | Specifies the SNMP parameter “sysDescr”. | Right away |
| | write | config_snmp description=<Value> | Change the SNMP parameter “sysDescr” (<Value> = string). * | After restart |
| Physical location | read | get_snmp_data physical-location | Specifies the SNMP “sysLocation” parameter. | Right away |
| | write | config_snmp physical-location=<Value> | Change the SNMP parameter “sysLocation” (<Value> = string). * | After restart |
| Contact | read | get_snmp_data contact | Specifies the SNMP “sysContact” parameter. | Right away |
| | write | config_snmp contact=<Value> | Change the SNMP parameter “sysContact” (<Value> = string). | After restart |
| * When entering values, the blank characters must be filled by either “+” or “%20”. If this is not done, the input is not recognized as a coherent string. | | | | |
| SNMP Manager configuration for v1 and v2c | | | | |
| Protocol status | read | get_snmp_data v1-v2c-state | Outputs the status of the SNMP protocol for v1/v2c as a string. Possible return values: - enabled - disabled | Right away |
| Local Community Name | read | get_snmp_data v1-v2c-community-name | Specifies the community name set for v1/v2c/ | Right away |
| Protocol Status/Community Name | write | config_snmp v1-v2c-state=<Value1> v1-v2c-community-name=<Value2> | Activates/deactivates the v1/v2c protocol (<Value1> = enabled or disabled) and assigns a community name. (<Value2> = string without spaces, min. 1, max. 32 characters). Note: No community name is required for deactivation. Activation is only possible by entering a community name. A community name can only be saved when the protocol is activated. | After restart |

Table 180: Description of configuration scripts for “SNMP”

| Parameters | Status | Call-Up | Output/Input | Valid |
|--|--------|---|--|---------------|
| SNMP Trap Receiver Configuration for v1 and v2c | | | | |
| Any number of trap receivers can be configured. A trap receiver that has been set up is always active; the data set must be completely deleted to deactivate it. | | | | |
| IP address of a trap receiver | read | get_snmp_data v1-v2c-trap-receiver-address <Number> | Specifies the IP address of the trap receiver that the controller is to send the v1 or v2 traps to. The <number> parameter enables consecutive reading of related data from the individually configured trap receiver for a short period of time (without interim changing of the data). This is a consecutive number that is not connected to the data. If the number is not included, the data of the first receiver are read. | Right away |
| Community Name | read | get_snmp_data v1-v2c-trap-receiver-community-name <Number> | Specifies the community name that the SNMP agent of the controller sends in the Trap Header. Parameter <number> see section “IP Address of a Trap Receiver”. | Right away |
| Trap version | read | get_snmp_data v1-v2c-trap-receiver-version <Number> | Specifies the SNMP version (“v1” or “v2c”) via which the SNMP agent sends the traps to the associated trap receiver address. Parameter <number> see section “IP Address of a Trap Receiver”. | Right away |
| Creating/ deleting a trap receiver | write | config_snmp v1-v2c-trap-receiver-edit=<Value1> v1-v2c-trap-receiver-address=<Value2> v1-v2c-trap-receiver-community-name=<Value3> v1-v2c-trap-receiver-version=<Value4> | Create a new trap receiver (value1=add) or delete an already configured trap receiver (value1=delete). Other parameters: <Value2> = IP address (number.number.number.number) that the controller is to send the traps to. <Value3>: Community string (string), which the controller enters in the trap header. <Value4>: SNMP version, via which the traps are sent (v1 or v2c). Note: All parameters must also be entered when deleting a trap receiver, as this is the only means to uniquely identify the data set. | After restart |

Table 180: Description of configuration scripts for “SNMP”

| Parameters | Status | Call-Up | Output/Input | Valid |
|---|--------|---|--|------------|
| Configuration of SNMP v3 | | | | |
| Any number of SNMP v3 users can be created. A user that has been set up is always active; the complete data set must be deleted to deactivate a user. | | | | |
| Authentication Name | read | get_snmp_data v3-auth-name <Number> | Specifies the user name for the v3 user. The <number> parameter enables consecutive reading of the related data from the individually configured trap receiver for a short period of time (without interim changing of the data). This is a consecutive number that is not connected to the data. If the number is not included, the data of the first user are read. | Right away |
| Authentication encryption type | read | get_snmp_data v3-auth-type <Number> | Specifies the type of encryption that the v3 user uses (none, MD5, or SHA). Parameter <number> see “Authentication Name”. | Right away |
| Authentication key | read | get_snmp_data v3-auth-key <Number> | Specifies the key string for authentication. Parameter <number> see “Authentication Name”. | Right away |
| Privacy encryption type | read | get_snmp_data v3-privacy <number> | Specifies the type of privacy encryption for the v3 user (none, DES, or AES). Parameter <number> see “Authentication Name”. | Right away |
| Privacy key | read | get_snmp_data v3-privacy-key <number> | Specifies the key string for privacy. If nothing is entered, the SNMP agent uses the “Authentication Key”. Parameter <number> see “Authentication Name”. | Right away |
| Trap receiver address | read | get_snmp_data v3-notification-receiver <number> | IP address of an SNMP manager that the agent traps for this v3 user are sent to. If nothing is entered here, no traps are sent for this user. Parameter <number> see “Authentication Name”. | Right away |

Table 180: Description of configuration scripts for “SNMP”

| Parameters | Status | Call-Up | Output/Input | Valid |
|-----------------|--------|---|---|---------------|
| Add new v3-User | write | <pre> config_snmp v3-edit=add v3-auth-name=<Value1> v3-auth-type=<Value2> v3-auth-key=<Value3> v3-privacy=<Value4> v3-privacy-key=<Value5> v3-notification-receiver=<Value6> </pre> | <p>Creating a new v3 user. v3-auth-name: User name, string without spaces, maximum of 32 characters. This must be a new, unique user name.</p> <p>Parameters: User name (<Value1> = string) Encryption method. (<Value2> = none, MD5 or SHA). Key string for authentication, (<Value3> = String with at least eight and a maximum of 32 characters) Privacy encryption method (<Value4> = none, DES or AES). Privacy key string (<Value5> = String with at least eight and a maximum of 32 characters), can also be blank; in this case the authentication key will be used. The IP address of a trap receiver is transmitted as the notification receiver (<Value6> = number.number.number.number) . This parameter is not required if no v3 traps are to be sent.</p> | After restart |
| Delete v3 user | write | <pre> config_snmp v3-edit=delete v3-auth-name=<Value> </pre> | <p>Deleting a v3 user that has been set up. Because the doubled allocation of the same user name is prevented when creating a user, the name is sufficient to uniquely identify a data set (<Value> = string).</p> | After restart |

13.2.1.10 WagoLibCpuUsage.lib

The controller 750-8202 supports the following function blocks of the “WagoLibCpuUsage.lib” library:

- CPU_Usage

The document containing the description of the library and the function block it includes is available for download on the Internet at www.wago.com.

13.2.1.11 WagoLibDiagnosticIDs.lib

The controller 750-8202 supports the following function blocks of the “WagoLibDiagnosticIDs.lib” library:

- DIAGNOSTIC_SEND_ID
- DIAGNOSTIC_SET_TEXT_FOR_ID

The document containing the description of the library and the function block it includes is available for download on the Internet at www.wago.com.

13.2.1.12 WagoLibLed.lib

The controller 750-8202 supports the following function blocks of the “WagoLibLed.lib” library:

- LED_SET_STATIC
- LED_SET_BLINK
- LED_SET_FLASH
- LED_SET_ERROR
- LED_RESET_ERROR
- LED_RESET_ALL_ERRORS
- LED_GET_STATE
- LED_GET_STATE_ASYNC

The document containing a description of this library and the function blocks it includes is available for download on the Internet at www.wago.com.

13.2.1.13 WagoLibNetSnmp.lib

The controller 750-8202 supports the following function blocks of the “WagoLibNetSnmp.lib” library:

- snmpGetValueCustomOID_INT32
- snmpGetValueCustomOID_STRING
- snmpGetValueCustomOID_UINT32
- snmpRegisterCustomOID_INT32
- snmpRegisterCustomOID_STRING
- snmpRegisterCustomOID_UINT32
- snmpSetValueCustomOID_INT32
- snmpSetValueCustomOID_STRING
- snmpSetValueCustomOID_UINT32

The document containing the description of the library and the function block it includes is available for download on the Internet at www.wago.com.

13.2.1.14 WagoLibNetSnmpManager.lib

The controller 750-8202 supports the following function blocks of the “WagoLibNetSnmpManager.lib” libraries:

- SNMPM_DINT_TO_TLV
- SNMPM_UDINT_TO_TLV
- SNMPM_STRING_TO_TLV
- SNMPM_TLV_TO_DINT
- SNMPM_TLV_TO_UDINT
- SNMPM_TLV_TO_STRING
- SNMPM_GET
- SNMPM_GET_V3

- SNMPM_SET
- SNMPM_SET_V3

The document containing a description of this library and the function blocks it includes is available for download on the Internet at www.wago.com.

13.2.1.15 WagoLibSSL.lib

The controller 750-8202 supports the following function blocks of the “WagoLibSSL.lib” library:

- SSL_CTX
- SSL_CTX_load_verify_locations
- SSL_CTX_sess_set_cache_size
- SSL_CTX_set_client_CA_list
- SSL_CTX_set_method
- SSL_CTX_use_certificate_file
- SSL_CTX_use_PrivateKey_file
- SSL_free
- SSL_get_error
- SSL_Handshk_Accept
- SSL_Handshk_Connect
- SSL_load_client_CA_file
- SSL_read
- SSL_shutdown
- SSL_write

The document containing a description of this library and the function blocks it includes is available for download on the Internet at www.wago.com.

13.2.1.16 WagoLibTerminalDiag.lib

The controller 750-8202 supports the following function blocks of the “WagoLibTerminalDiag.lib” library:

- GET_TERMINALDIAG

The document containing a description of this library and the function blocks it includes is available for download on the Internet at www.wago.com.

List of Figures

| | |
|--|-----|
| Figure 1: View of device | 23 |
| Figure 2: Data contacts | 25 |
| Figure 3: Power Jumper Contacts | 26 |
| Figure 4: CAGE CLAMP® connections | 27 |
| Figure 5: Service interface, (closed and open flap) | 28 |
| Figure 6: Network connections – X1, X2 | 29 |
| Figure 7: RS-232/RS-485 – X3 communication connection | 30 |
| Figure 8: Termination with DTE-DCE connection (1:1) | 31 |
| Figure 9: Termination with DTE-DTE connection (cross-over) | 31 |
| Figure 10: RS-485 bus termination | 32 |
| Figure 11: Power supply indicating elements | 33 |
| Figure 12: Indicating elements for fieldbus/system | 34 |
| Figure 13: Indicating elements, memory card slot | 35 |
| Figure 14: Indicating elements, RJ-45 jacks | 36 |
| Figure 15: Mode selector switch | 37 |
| Figure 16: Reset button | 38 |
| Figure 17: Memory card slot | 39 |
| Figure 18: Schematic diagram | 40 |
| Figure 19: Spacing | 49 |
| Figure 20: Release Tab of Controller | 51 |
| Figure 21: Insert I/O Module (Example) | 52 |
| Figure 22: Snap the I/O Module into Place (Example) | 52 |
| Figure 23: Connecting a conductor to a CAGE CLAMP® | 54 |
| Figure 24: Power Supply Concept | 55 |
| Figure 25: “Open DHCP”, example figure | 60 |
| Figure 26: CBM starting screen | 61 |
| Figure 27: CBM – Selecting “Networking” | 61 |
| Figure 28: CBM – Selecting “TCP/IP” | 62 |
| Figure 29: CBM – Selecting “IP address” | 62 |
| Figure 30: CBM – Selecting the IP address | 63 |
| Figure 31: CBM – Entering a new IP address | 63 |
| Figure 32: “WAGO Ethernet Settings” – Starting screen | 64 |
| Figure 33: “WAGO Ethernet Settings” – “Network” tab | 65 |
| Figure 34: Example of a function test | 66 |
| Figure 35: Entering authentication | 74 |
| Figure 36: Password reminder | 74 |
| Figure 37: WBM browser window (example) | 76 |
| Figure 38: WBM status information (example) | 76 |
| Figure 39: “WAGO ETHERNET Settings” – Start screen | 110 |
| Figure 40: “WAGO ETHERNET Settings” – Communication link | 111 |
| Figure 41: “WAGO ETHERNET Settings” – Identification tab (example) | 112 |
| Figure 42: “WAGO ETHERNET Settings” – Network tab | 113 |
| Figure 43: “WAGO ETHERNET Settings” – Protocol tab | 115 |
| Figure 44: “WAGO ETHERNET Settings” – Status tab | 116 |
| Figure 45: Target system settings (1) | 118 |
| Figure 46: Target system settings (2) | 118 |
| Figure 47: Creating a new function block | 119 |
| Figure 48: Programming interface with the PLC_PRG program module | 119 |

| | |
|---|-----|
| Figure 49: “Resources” tab..... | 120 |
| Figure 50: Control configuration – Edit..... | 121 |
| Figure 51: “Start WAGO-I/O-CHECK and scan” button | 121 |
| Figure 52: WAGO-I/O-CHECK – Starting screen..... | 122 |
| Figure 53: I/O Configurator empty | 123 |
| Figure 54: “Add I/O modules” button..... | 123 |
| Figure 55: “Module selection” window | 124 |
| Figure 56: I/O Configurator with defined I/O modules | 124 |
| Figure 57: Variable declaration..... | 125 |
| Figure 58: Control configuration: I/O modules with their associated addresses | 125 |
| Figure 59: Program function block | 126 |
| Figure 60: Input assistant for selecting variables | 126 |
| Figure 61: Example of an allocation | 127 |
| Figure 62: Creating a communication link – Step 1..... | 128 |
| Figure 63: Creating a communication link – Step 2..... | 129 |
| Figure 64: Creating a communication link – Step 3..... | 129 |
| Figure 65: Task configuration | 131 |
| Figure 66: Changing task names 1 | 132 |
| Figure 67: Call-up to add to the program module..... | 133 |
| Figure 68: Cyclic task..... | 134 |
| Figure 69: Freewheeling task | 135 |
| Figure 70: CODESYS – System events | 136 |
| Figure 71: CODESYS program provokes division by “0”..... | 138 |
| Figure 72: CODESYS – Creating and activating an event handler | 138 |
| Figure 73: CODESYS – New module has been generated | 139 |
| Figure 74: CODESYS – Enter the event in a global variable | 139 |
| Figure 75: CODESYS – Variable contents prior to division by “0”..... | 140 |
| Figure 76: CODESYS – Variable contents after division by “0” and call-up of the event handler..... | 140 |
| Figure 77: Process image | 141 |
| Figure 78: Flag area..... | 142 |
| Figure 79: Internal data bus synchronization 01 | 146 |
| Figure 80: I/O module synchronization 02..... | 147 |
| Figure 81: I/O module synchronization 03..... | 148 |
| Figure 82: Internal data bus synchronization 04 | 149 |
| Figure 83: Internal data bus settings..... | 150 |
| Figure 84: Program memory | 153 |
| Figure 85: Data memory and function block limitation..... | 154 |
| Figure 86: Remanent main memory..... | 154 |
| Figure 87: Flag and retain memory | 155 |
| Figure 88: Selecting the visualization technique in the target system settings ... | 156 |
| Figure 89: Creating the PLC_VISU starting visualization..... | 157 |
| Figure 90: CODESYS control system configuration - MODBUS settings..... | 164 |
| Figure 91: MODBUS process image..... | 170 |
| Figure 92: Flag area..... | 171 |
| Figure 93: Power supply indicating elements | 189 |
| Figure 94: Indicating elements for fieldbus/system | 190 |
| Figure 95: Flashing sequence process diagram..... | 194 |
| Figure 96: Inserting the memory card | 202 |
| Figure 97: Release Tab of Controller | 204 |

Figure 98: Removing the I/O Module (Example) 205
Figure 99: Graphical Representation of the “ConfigToolFB” Function Block... 240

List of Tables

| | |
|---|----|
| Table 1: Variants | 11 |
| Table 2: Number Notation..... | 14 |
| Table 3: Font Conventions | 14 |
| Table 4: Legend for figure “Device view” | 23 |
| Table 5: Legend for Figure “Power Jumper Contacts” | 26 |
| Table 6: Legend for figure “CAGE CLAMP® connections” | 27 |
| Table 7: Service interface..... | 28 |
| Table 8: Legend for Figure "Network Connections – X1, X2" | 29 |
| Table 9: Key for the “RS-232/RS-485 – X3 communication connection” figure. | 30 |
| Table 10: Function of RS-232 signals for DTE/DCE | 31 |
| Table 11: Legend for Figure “Power Supply Indicating Elements” | 33 |
| Table 12: Legend for figure “Fieldbus/System Indicating Elements” | 34 |
| Table 13: Legend for figure “Indicating Elements, memory card slot” | 35 |
| Table 14: Legend for figure “Indicating elements, RJ-45 jacks” | 36 |
| Table 15: Mode selector switch..... | 37 |
| Table 16: Technical data, device data | 41 |
| Table 17: Technical Data – System Data | 41 |
| Table 18: Technical Data – Power Supply | 41 |
| Table 19: Technical data – Clock..... | 41 |
| Table 20: Technical Data – Programming | 42 |
| Table 21: Technical Data – Internal Data Bus | 42 |
| Table 22: Technical Data – ETHERNET | 42 |
| Table 23: Technical Data – Serial Interface | 42 |
| Table 24: Technical Data – Field Wiring..... | 43 |
| Table 25: Technical Data – Power Jumper Contacts | 43 |
| Table 26: Technical Data – Data Contacts | 43 |
| Table 27: Technical Data – Climatic Environmental Conditions | 43 |
| Table 28: WAGO DIN Rail..... | 49 |
| Table 29: Filter Modules for 24 V Supply | 55 |
| Table 30: Default IP Addresses for ETHERNET Interfaces..... | 59 |
| Table 31: Network Mask 255.255.255.0 | 59 |
| Table 32: WBM Users..... | 71 |
| Table 33: Linux® Users | 71 |
| Table 34: User Settings in the Initial State..... | 74 |
| Table 35: Access Rights for WBM Pages | 75 |
| Table 36: WBM “Status Information” page – “Controller Details” group | 78 |
| Table 37: WBM “Status Information” page – “Network Details (Xn)” group(s). | 78 |
| Table 38: WBM “CODESYS Configuration” page – “General Configuration” group | 79 |
| Table 39: WBM “CODESYS – Information” page – “CODESYS” group | 80 |
| Table 40: WBM “CODESYS Information” page – “Project Details” group..... | 80 |
| Table 41: WBM “CODESYS Information” page – “Task n” group(s) | 81 |
| Table 42: WBM “CODESYS WebVisu” page – “Webserver Configuration” group | 82 |
| Table 43: WBM “Configuration of Network Parameters” page – “Hostname” group | 83 |
| Table 44: WBM “Configuration of Network Parameters” page – “Domain Name” group | 83 |

| | |
|--|-----|
| Table 45: WBM “TCP/IP Configuration” page – “Switch Configuration” group | 84 |
| Table 46: WBM “TCP/IP Configuration” page – “IP Address (Xn)” group(s).... | 84 |
| Table 47: WBM “TCP/IP Configuration” page – “Default Gateway” group | 85 |
| Table 48: WBM “TCP/IP Configuration” page – “DNS Server” group | 85 |
| Table 49: WBM “Configuration of ETHERNET Parameters” page – “Interface Xn” groups | 86 |
| Table 50: WBM “Configuration of Time and Date” page – “Date on Device” group | 87 |
| Table 51: WBM “Configuration of time and date” page – “Time on Device” group | 87 |
| Table 52: WBM “Configuration of time and date” page – “Time Zone” group... | 88 |
| Table 53: WBM “Configuration of time and date” page – “TZ String” group..... | 88 |
| Table 54: WBM “Configuration of the users for the Web-based Management” page – “Change Password for selected user” group | 89 |
| Table 55: WBM “Create Bootable Image” page – “Create bootable image from active partition” group | 90 |
| Table 56: WBM “Configuration of Serial Interface RS232” page – “Assign Owner of serial Interface” group | 91 |
| Table 57: WBM “Mass Storage” page – “<Device Name>” group..... | 96 |
| Table 58: WBM “Mass Storage” page – “<Device Name>” group..... | 96 |
| Table 59: WBM “Software Uploads” page – “Upload New Software” group | 97 |
| Table 60: WBM “Software Uploads” page – “Activate New Software” group ... | 97 |
| Table 61: WBM “Configuration of Network Services” page – “Telnet” group ... | 98 |
| Table 62: WBM “Configuration of Network Services” page – “FTP” group..... | 98 |
| Table 63: WBM “Configuration of Network Services” page – “FTPS” group | 98 |
| Table 64: WBM “Configuration of Network Services” page – “HTTP” group ... | 98 |
| Table 65: WBM “Configuration of Network Services” page – “HTTPS” group . | 98 |
| Table 66: WBM “Configuration of NTP Client” page – “NTP Client” group | 99 |
| Table 67: WBM “Configuration of the CODESYS Services” page – “CODESYS Webserver” group | 100 |
| Table 68: WBM “Configuration of the CODESYS Services” page – “Communication” group | 100 |
| Table 69: WBM “Configuration of the CODESYS Services” page – “Port Authentication” group..... | 100 |
| Table 70: WBM “Configuration of the CODESYS Services” page – “Port Authentication Password” group | 100 |
| Table 71: WBM “SSH Client Settings” page – “SSH Client” group..... | 101 |
| Table 72: WBM “TFTP Server” page – “TFTP Server” group | 102 |
| Table 73: WBM “Configuration of SNMP parameter” page – “General SNMP Configuration” group | 103 |
| Table 74: WBM “Configuration of SNMP parameter” page – “SNMP v1/v2c Manager Configuration” group..... | 104 |
| Table 75: WBM “Configuration of SNMP parameter” page – “Actually Configured Trap Receivers” group | 104 |
| Table 76: WBM “Configuration of SNMP parameter” page – “Trap Receiver n” group | 105 |
| Table 77: WBM “Configuration of SNMP parameter” page – “Add new Trap Receiver” group | 105 |
| Table 78: WBM “Configuration of SNMP v3” page – “Actually Configured v3 Users” group | 106 |

| | |
|---|-----|
| Table 79: WBM “Configuration of SNMP v3 Users” page – “v3 User n” group(s) | 106 |
| Table 80: WBM “Configuration of SNMP v3 Users” page – “Add new v3 User” group | 107 |
| Table 81: WBM “Diagnostic Information” page | 108 |
| Table 82: Syntax of logical addresses | 130 |
| Table 83: Events | 137 |
| Table 84: Access to the Process Images of the Input and Output Data – Internal Data Bus | 143 |
| Table 85: Access to the Process Images of the Input and Output Data – MODBUS | 144 |
| Table 86: Access to the Process Images of the Input and Output Data – Flags.. | 144 |
| Table 87: Arrangement of the I/O modules for the addressing example | 144 |
| Table 88: Internal Data Bus Settings | 151 |
| Table 89: Errors and remedies | 160 |
| Table 90: MODBUS Settings | 165 |
| Table 91: MODBUS TCP Settings | 166 |
| Table 92: MODBUS UDP Settings | 166 |
| Table 93: MODBUS RTU Settings | 167 |
| Table 94: MODBUS Mapping for Read Bit Services FC1, FC2 | 172 |
| Table 95: MODBUS mapping for write bit services FC5, FC15 | 173 |
| Table 96: MODBUS Mapping for Read Register Services FC3, FC4, FC23 | 174 |
| Table 97: MODBUS mapping for write register services FC6, FC16, FC22, FC23 | 176 |
| Table 98: WAGO MODBUS Registers | 178 |
| Table 99: Watchdog Commands | 182 |
| Table 100: Watchdog Status | 183 |
| Table 101: Watchdog Configuration | 184 |
| Table 102: Diagnostics for the Error Server | 186 |
| Table 103: Legend for Figure “Power Supply Indicating Elements” | 189 |
| Table 104: Field-Side Supply Diagnostics | 189 |
| Table 105: System Power Supply Diagnostics | 189 |
| Table 106: Diagnostics SYS LED | 190 |
| Table 107: Diagnostics RUN LED | 191 |
| Table 108: Diagnostics I/O LED | 192 |
| Table 109: Overview of Error Codes | 196 |
| Table 110: Error Code 1, Explanation of Blink Codes and Procedures for Troubleshooting | 197 |
| Table 111: Error Code 3, Explanation of Blink Codes and Procedures for Troubleshooting | 199 |
| Table 112: Error Code 4, Explanation of Blink Codes and Procedures for Troubleshooting | 200 |
| Table 113: Error Code 5, Explanation of Blink Codes and Procedures for Troubleshooting | 200 |
| Table 114: Error Code 6, Explanation of Blink Codes and Procedures for Troubleshooting | 200 |
| Table 115: Error Code 9, Explanation of Blink Codes and Procedures for Troubleshooting | 201 |
| Table 116: 1 Channel Digital Input Module with Diagnostics | 207 |
| Table 117: 2 Channel Digital Input Modules | 207 |

| | |
|---|-----|
| Table 118: 2 Channel Digital Input Module with Diagnostics | 207 |
| Table 119: 2 Channel Digital Input Module with Diagnostics and Output Process Data | 208 |
| Table 120: 4 Channel Digital Input Modules | 208 |
| Table 121: 8 Channel Digital Input Modules | 208 |
| Table 122: 8 Channel Digital Input Module PTC with Diagnostics and Output Process Data | 209 |
| Table 123: 16 Channel Digital Input Modules | 209 |
| Table 124: 1 Channel Digital Output Module with Input Process Data | 210 |
| Table 125: 2 Channel Digital Output Modules | 210 |
| Table 126: 2 Channel Digital Input Modules with Diagnostics and Input Process Data | 211 |
| Table 127: 2 Channel Digital Input Modules with Diagnostics and Input Process Data 75x-506 | 211 |
| Table 128: 4 Channel Digital Output Modules | 212 |
| Table 129: 4 Channel Digital Output Modules with Diagnostics and Input Process Data | 212 |
| Table 130: 8 Channel Digital Output Module | 212 |
| Table 131: 8 Channel Digital Output Modules with Diagnostics and Input Process Data | 213 |
| Table 132: 16 Channel Digital Output Modules | 213 |
| Table 133: 8 Channel Digital Input/Output Modules | 214 |
| Table 134: 1 Channel Analog Input Modules | 215 |
| Table 135: 2 Channel Analog Input Modules | 215 |
| Table 136: 4 Channel Analog Input Modules | 216 |
| Table 137: 3-Phase Power Measurement Module | 217 |
| Table 138: 8 Channel Analog Input Modules | 217 |
| Table 139: 2 Channel Analog Output Modules | 218 |
| Table 140: 4 Channel Analog Output Modules | 218 |
| Table 141: Counter Modules 750-404, (and all variations except of /000-005), 753-404, (and variation /000-003) | 219 |
| Table 142: Counter Modules 750-404/000-005 | 220 |
| Table 143: Counter Modules 750-638, 753-638 | 220 |
| Table 144: Pulse Width Modules 750-511, /xxx-xxx | 221 |
| Table 145: Serial Interface Modules with alternative Data Format | 221 |
| Table 146: Serial Interface Modules with Standard Data Format | 222 |
| Table 147: Data Exchange Module | 222 |
| Table 148: SSI Transmitter Interface Modules | 223 |
| Table 149: Incremental Encoder Interface Modules 750-631/000-004, --010, -011 | 223 |
| Table 150: Incremental Encoder Interface Modules 750-634 | 224 |
| Table 151: Incremental Encoder Interface Modules 750-637 | 224 |
| Table 152: Digital Pulse Interface Modules 750-635 | 225 |
| Table 153: DC-Drive Controller 750-636 | 225 |
| Table 154: Stepper Controller RS 422 / 24 V / 20 mA 750-670 | 226 |
| Table 155: RTC Module 750-640 | 227 |
| Table 156: DALI/DSI Master Module 750-641 | 227 |
| Table 157: Overview of Input Process Image in the "Easy" Mode | 229 |
| Table 158: Overview of the Output Process Image in the "Easy" Mode“ | 229 |
| Table 159: EnOcean Radio Receiver 750-642 | 230 |

| | |
|--|-----|
| Table 160: MP Bus Master Module 750-643 | 231 |
| Table 161: Bluetooth® RF-Transceiver 750-644..... | 231 |
| Table 162: Vibration Velocity/Bearing Condition Monitoring VIB I/O 750-645 | 232 |
| Table 163: KNX/EIB/TP1 Module 753-646 | 233 |
| Table 164: AS-interface Master Module 750-655 | 234 |
| Table 165: System Modules with Diagnostics 750-610, -611 | 235 |
| Table 166: Binary Space Module 750-622 (with Behavior Like 2 Channel Digital Input)..... | 235 |
| Table 167: CODESYS System Libraries | 236 |
| Table 168: Input Variable “DEVICE NUMBER” | 239 |
| Table 169: Description of the Configuration Scripts for “Information” | 240 |
| Table 170: Description of the Configuration Scripts for “CODESYS” | 241 |
| Table 171: Description of the Configuration Scripts for “Networking - Host- /Domain-Name” | 241 |
| Table 172: Description of the Configuration Scripts for “Networking - TCP/IP” | 242 |
| Table 173: Description of the Configuration Scripts for “Networking - ETHERNET” | 244 |
| Table 174: Description of the Configuration Scripts for “CODESYS” | 245 |
| Table 175: Description of the Configuration Scripts for “NTP” | 246 |
| Table 176: Description of the Configuration Scripts for “Clock” | 247 |
| Table 177: Description of the Configuration Scripts for “Administration” | 247 |
| Table 178: Description of Configuration Scripts for “Package Server” | 248 |
| Table 179: Description of Configuration Scripts for “Ports and Services” | 248 |
| Table 180: Description of configuration scripts for “SNMP” | 252 |

WAGO Kontakttechnik GmbH & Co. KG
Postfach 2880 • D-32385 Minden
Hansastraße 27 • D-32423 Minden
Phone: +49/5 71/8 87 – 0
Fax: +49/5 71/8 87 – 1 69
E-Mail: info@wago.com
Internet: <http://www.wago.com>

