

## 7186.5010

Encoder distributor, cross switcher and splitter for incremental encoder signals

### Product Features:

- Universal encoder interface, applicable as level converter, encoder splitter and cross switch
- Two encoder inputs (A, /A, B, /B, Z, /Z), adjustable either to HTL, TTL or RS422 level
- Suitable for quadrature, symmetrical, asymmetrical as well as single channel signals
- Two signal outputs (A, /A, B, /B, Z, /Z), adjustable either to HTL, TTL or RS422 level
- Contactless and bounce-free switch-over between the encoder channels, by remote control signals
- Auxiliary output 5 VDC for encoder supply
- High frequency range up to 1 MHz

<b>Version:</b>	<b>Description:</b>
7186.5010_01b/ Feb.05 /af/hk	Original version released
7186.5010_01c/ Jul. 05 /hk	Terminal assignments and coding (X1 – X5)
7186.5010_01d/ Aug.05 /hk	Clarification RS422 /differential and HTL /single-ended operation
7186.5010_01e/ Jul.07 /hk	Corrections TTL-single-ended, outlines and dimensions
7186.5010_02a/ Feb 08 /hk	New version, 1 MHz, DIL switch for TTL single-ended
7186.5010_02b/ Dec 11 /mb	Temperature range
7186.5010_02c/ Apr 12 /pp	Chapter 6 : Corrected Dimension Drawing (DIL)
7186.5010_02d/ Sep 13 /af/nw	Correction "Technical Specifications"
7186.5010_02e/ Feb.15/ag	Some modifications and modulations. Safety Instructions & Technical Specifications renewed.
7186.5010_02e_oi/Jan-16/ag	Extended temperature range modified. Design updated and "Legal notices" added.

#### **Legal notices:**

All contents included in this manual are protected by the terms of use and copyrights of motrona GmbH. Any reproduction, modification, usage or publication in other electronic and printed media as well as in the internet requires prior written authorization by motrona GmbH.

# Table of Contents

<b>1. Safety Instructions and Responsibility .....</b>	<b>4</b>
1.1 General Safety Instructions.....	4
1.2 Use according to the intended purpose .....	4
1.3 Installation.....	5
1.4 Cleaning, Maintenance and Service Notes.....	5
<b>2. Applications .....</b>	<b>6</b>
2.1. Dual level converter .....	6
2.2. Encoder splitter (dual output).....	6
2.3. Encoder signal switcher .....	7
<b>3. Connection Diagram .....</b>	<b>8</b>
3.1. Power supply .....	8
3.2. Control inputs .....	8
3.3. Incremental inputs.....	8
3.4. Asymmetric TTL Inputs.....	9
3.5. Incremental Outputs .....	9
<b>4. The Front LEDs.....</b>	<b>10</b>
<b>5. Switch Settings .....</b>	<b>11</b>
<b>6. Dimensions.....</b>	<b>12</b>
<b>7. Technical Specifications .....</b>	<b>13</b>

# 1. Safety Instructions and Responsibility

## 1.1 General Safety Instructions

This operation manual is a significant component of the unit and includes important rules and hints about the installation, function and usage. Non-observance can result in damage and/or impairment of the functions to the unit or the machine or even in injury to persons using the equipment!

**Please read the following instructions carefully before operating the device and observe all safety and warning instructions! Keep the manual for later use.**

A pertinent qualification of the respective staff is a fundamental requirement in order to use these manual. The unit must be installed, connected and put into operation by a qualified electrician.

**Liability exclusion:** The manufacturer is not liable for personal injury and/or damage to property and for consequential damage, due to incorrect handling, installation and operation. Further claims, due to errors in the operation manual as well as misinterpretations are excluded from liability.

In addition the manufacturer reserve the right to modify the hardware, software or operation manual at any time and without prior notice. Therefore, there might be minor differences between the unit and the descriptions in operation manual.

The raiser respectively positioner is exclusively responsible for the safety of the system and equipment where the unit will be integrated.

During installation or maintenance all general and also all country- and application-specific safety rules and standards must be observed.

If the device is used in processes, where a failure or faulty operation could damage the system or injure persons, appropriate precautions to avoid such consequences must be taken.

## 1.2 Use according to the intended purpose

The unit is intended exclusively for use in industrial machines, constructions and systems. Non-conforming usage does not correspond to the provisions and lies within the sole responsibility of the user. The manufacturer is not liable for damages which has arisen through unsuitable and improper use.

Please note that device may only be installed in proper form and used in a technically perfect condition - in accordance to the "Technical Specifications" (see chapter [7](#)). The device is not suitable for operation in explosion-proof areas or areas which are excluded by the EN 61010-1 standard.

## 1.3 Installation

The device is only allowed to be installed and operated within the permissible temperature range. Please ensure an adequate ventilation and avoid all direct contact between the device and hot or aggressive gases and liquids.

Before installation or maintenance, the unit must be disconnected from all voltage-sources. Further it must be ensured that no danger can arise by touching the disconnected voltage-sources.

Devices which are supplied by AC-voltages, must be connected exclusively by switches, respectively circuit-breakers with the low voltage network. The switch or circuit-breaker must be placed as near as possible to the device and further indicated as separator.

Incoming as well as outgoing wires and wires for extra low voltages (ELV) must be separated from dangerous electrical cables (SELV circuits) by using a double resp. increased isolation.

All selected wires and isolations must be conform to the provided voltage- and temperature-ranges. Further all country- and application-specific standards, which are relevant for structure, form and quality of the wires, must be ensured. Indications about the permissible wire cross-sections for wiring are described in the Technical Specifications (see chapter [7](#)).

Before first start-up it must be ensured that all connections and wires are firmly seated and secured in the screw terminals. All (inclusively unused) terminals must be fastened by turning the relevant screws clockwise up to the stop.

Overvoltages at the connections must be limited to values in accordance to the overvoltage category II.

For placement, wiring, environmental conditions as well as shielding and earthing/grounding of the supply lines the general standards of industrial automation industry and the specific shielding instructions of the manufacturer are valid. Please find all respective hints and rules on [www.motrona.com/download.html](http://www.motrona.com/download.html) --> "[General EMC Rules for Wiring, Screening and Earthing]".

## 1.4 Cleaning, Maintenance and Service Notes

To clean the front of the unit please use only a slightly damp (not wet!), soft cloth. For the rear no cleaning is necessary. For an unscheduled, individual cleaning of the rear the maintenance staff or assembler is self-responsible.

During normal operation no maintenance is necessary. In case of unexpected problems, failures or malfunctions the device must be shipped for back to the manufacturer for checking, adjustment and reparation (if necessary). Unauthorized opening and repairing can have negative effects or failures to the protection-measures of the unit..

## 2. Applications

### 2.1. Dual level converter

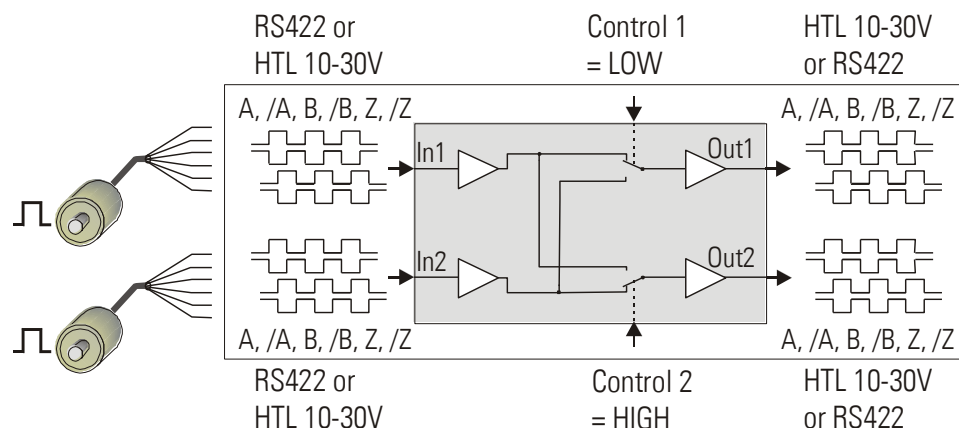

Both inputs can be individually set to either symmetric (differential) format using A, /A, B, /B, Z, /Z channels, or to asymmetric (single-ended) format using A, B, Z channels only. Acceptable input levels are RS422, TTL and HTL 10 ... 30 V.

The output format can again be selected individually for each output. The outputs provide always all signals including the inverted channels, even when no inverted signals are applied to the input.

With Control input 1 = LOW (or unconnected) and Control input 2 = HIGH the signal ways are as shown in the drawing above, featuring two independent level converters.

### 2.2. Encoder splitter (dual output)

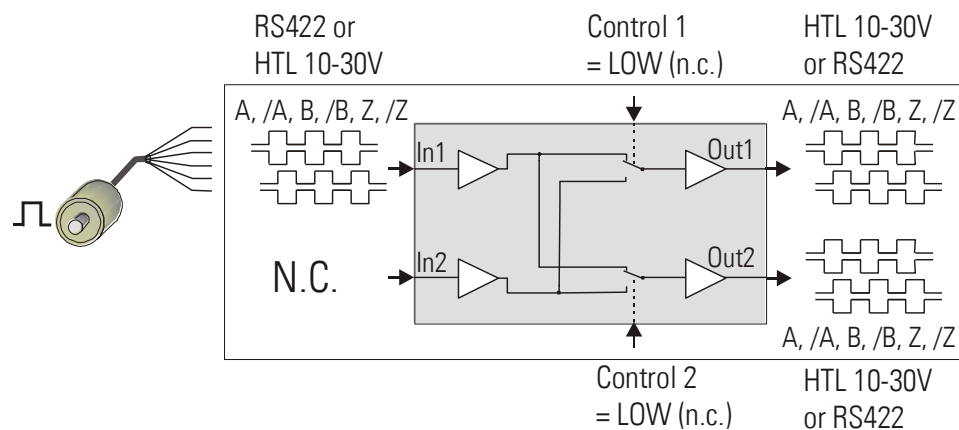

Input 1 is used as encoder input, and Input 2 remains unconnected. The input can be set to either symmetric (differential) format using A, /A, B, /B, Z, /Z channels, or to asymmetric (single-ended) format using A, B, Z channels only. Acceptable input levels are RS422, TTL and HTL 10 ... 30 V.

The output standard can again be selected individually for each output. The outputs provide always all signals including the inverted channels, even when no inverted signals are applied to the input. Control1 and Control2 remain unconnected with this application.

## 2.3. Encoder signal switcher

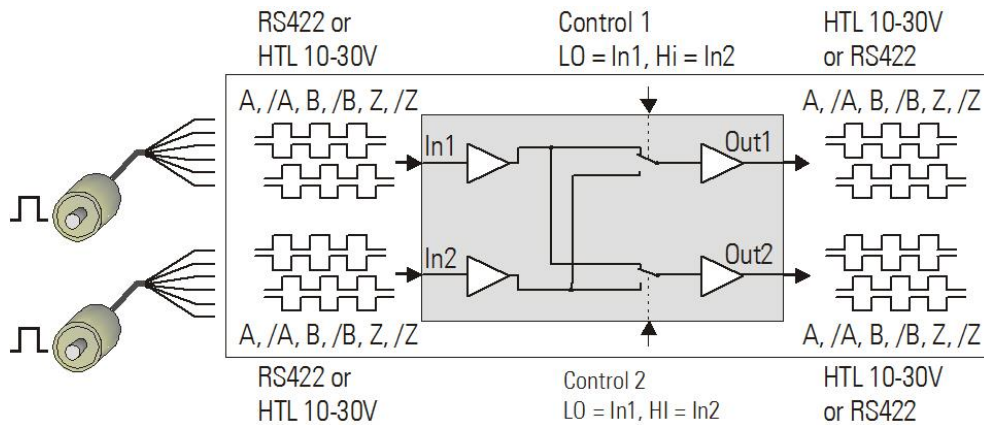

Both inputs can be individually set to either symmetric (differential) format using A, /A, B, /B, Z, /Z channels, or to asymmetric (single-ended) format using A, B, Z channels only. Acceptable input levels are RS422, TTL and HTL 10 ... 30 V.

The output standard can again be selected individually for each output. The outputs provide always all signals including the inverted channels, even when no inverted signals are applied to the input.

Inputs Control1 and Control2 select the signal ways:

- **LOW:** The corresponding output is connected to input 1
- **HIGH:** The corresponding output is connected to input 2

## 3. Connection Diagram

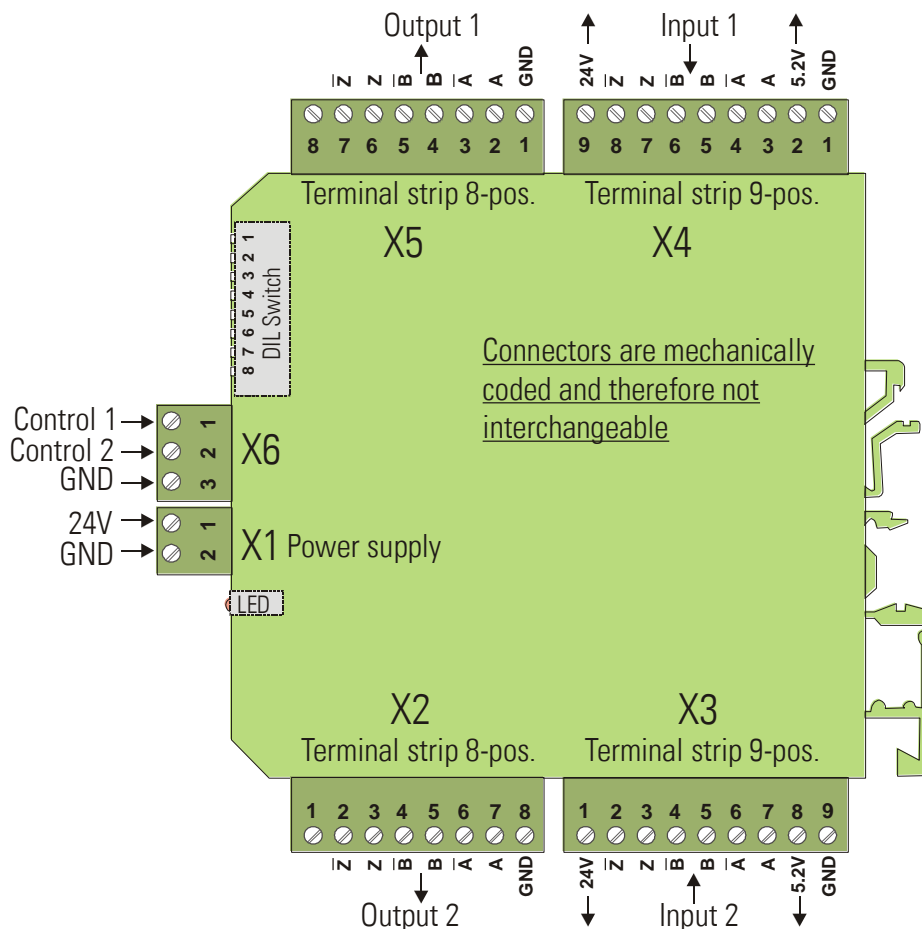

### 3.1. Power supply

The unit requires a 12 ... 30 VDC power supply via the 2-position power terminal on the front side (terminal 1 = +, terminal 2 = GND). The current consumption is about 50 mA (in case of unloaded aux. voltages and outputs).

### 3.2. Control inputs

The control inputs are accessible via the 3-position terminal strip on the front. They are in LOW state when unconnected. To switch the inputs to HIGH state, a signal from +10 to +30 V must be applied to the corresponding terminal.

### 3.3. Incremental inputs

The input lines can be configured for different requirements by DIL switch setting. The following input formats can be used:

- Single-ended signals (asymmetric), channels A, B and Z only without inverted inputs (Level is HTL 10 ... 30 V in general, exceptionally also TTL, see chapter 3.4). A, B and Z can also be single-signals, e. g. from light barriers (for example only channel A is connected).
- Differential signals (symmetric), channels A, /A, B, /B, Z, /Z (levels either according to RS422 standard or TTL or HTL 10 ... 30 V)



A, B and Z may at any time also be independent single signals, e.g. from proximities, photocells etc. Since the level of every channel is selected individually (see DIL-switch), it is possible to use different levels on the inputs. Consequently it is e.g. possible to take the position information from the A, /A, B and /B channels of a RS422 encoder, but to add the corresponding Z index pulse as a HTL signal from a remote photocell

With HTL signals, the switching threshold lies between 6.5 and 8 V. The input uses an internal pull-down resistor of 5kOhms.

Every of the two input terminals provides two auxiliary voltage outputs for easy encoder supply: +5.2 V / 125 mA and +24 V\* / 125 mA

\*) Output = power supply voltage minus 2 V

### 3.4. Asymmetric TTL Inputs

Only when exceptionally asymmetric TTL input signals must be processed (i.e. TTL signals without inverted signal), a 2-position DIL switch located behind the front plate must be set. This hidden switch becomes accessible by slightly lifting up the front foil at the lower end (e.g. by means of a small screw driver)

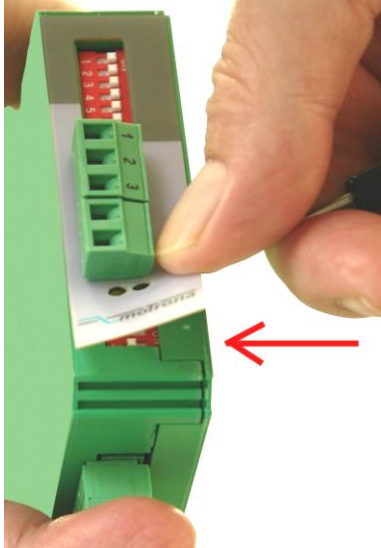

Switch position 1 is responsible for all channels of Input 1  
Switch position 2 is responsible for all channels of Input 2  
OFF = Asymmetric operation with HTL levels (10 – 30 V)  
ON = Asymmetric operation with TTL levels

 Ex-factory both switches are OFF, i.e. any single-ended operation requires HTL levels (this is the normal case)

 Asymmetric TTL levels are most sensitive to noise and interference, therefore not suitable for cable transmission in an industrial environment!

For all general applications please do not touch the DIL switch hidden behind the front plate!

### 3.5. Incremental Outputs

The outputs provide push-pull characteristics. When set to TTL/RS422 level, the corresponding output swing is always 5 V. When set to HTL, the output swing depends on the power supply input (12 ... 30 V). All outputs are short-circuit-proof.

At any time the signal and the appropriate inverted signal are both available at the output, even when no inverted signal is applied to the input.

## 4. The Front LEDs

The green LED is lit as soon as a power supply voltage is applied to the unit.

The yellow LED indicates the state of the Control inputs and the basic function of the unit:

**Yellow LED off:** Control1 and Control2 are either both LOW or both HIGH at the same time. In this case the unit operates as a splitter (both outputs are connected to the same input)

**Yellow LED on:** Control1 and Control2 have different states. In this case the unit operates as a dual level converter or as a switcher (the outputs are connected to different inputs)

# 5. Switch Settings

The DIL switch sets level and standard of inputs and outputs:

0=OFF 1=ON								DIL switch settings	
8	7	6	5	4	3	2	1		
							0	Output 1: TTL / RS422	The output levels are 5 V with TTL setting and correspond to the power supply voltage with HTL setting
							1	Output 1: HTL	
						0	Output 2: TTL / RS422		
						1	Output 2: HTL		
			0 (Z)	0 (B)	0 (A)			Input 1: differential (A, /A, B, /B, Z, /Z)	Both, input and inverted input must be used. Levels from 2 up to 30 V are acceptable.
			1 (Z)	1 (B)	1 (A)			Input 1: single-ended (A,B,Z) with HTL level *)	Inverted inputs remain open, level must be HTL 10... 30 V
0 (Z)	0 (B)	0 (A)						Input 2: differential (A, /A, B, /B, Z, /Z)	Both, input and inverted input must be used. Levels from 2 to 30 V are acceptable.
1 (Z)	1 (B)	1 (A)						Input 2: single-ended (A,B,Z) with HTL level *)	Inverted inputs remain open, level must be HTL 10 ... 30 V

\*) This setting can also be used with asymmetric (single-ended) TTL levels. See [3.4](#)



**Please set unused input lines to “single-ended” HTL at any time!**

It is not mandatory to use the same level for all channels of an input.

The indications (A), (B), (Z) show which switch position is responsible for which channel.

When e.g. positions 3 and 4 are set to “0” and position 5 is set to “1”, Input1 would accept A, /A, B, /B at RS422 standard, and the Z index as a HTL single-ended signal.

Consequently it is possible to e.g. generate an Index from a remote photocell, whereas the impulses come from the RS422 encoder simulation of a drive system.

# 6. Dimensions

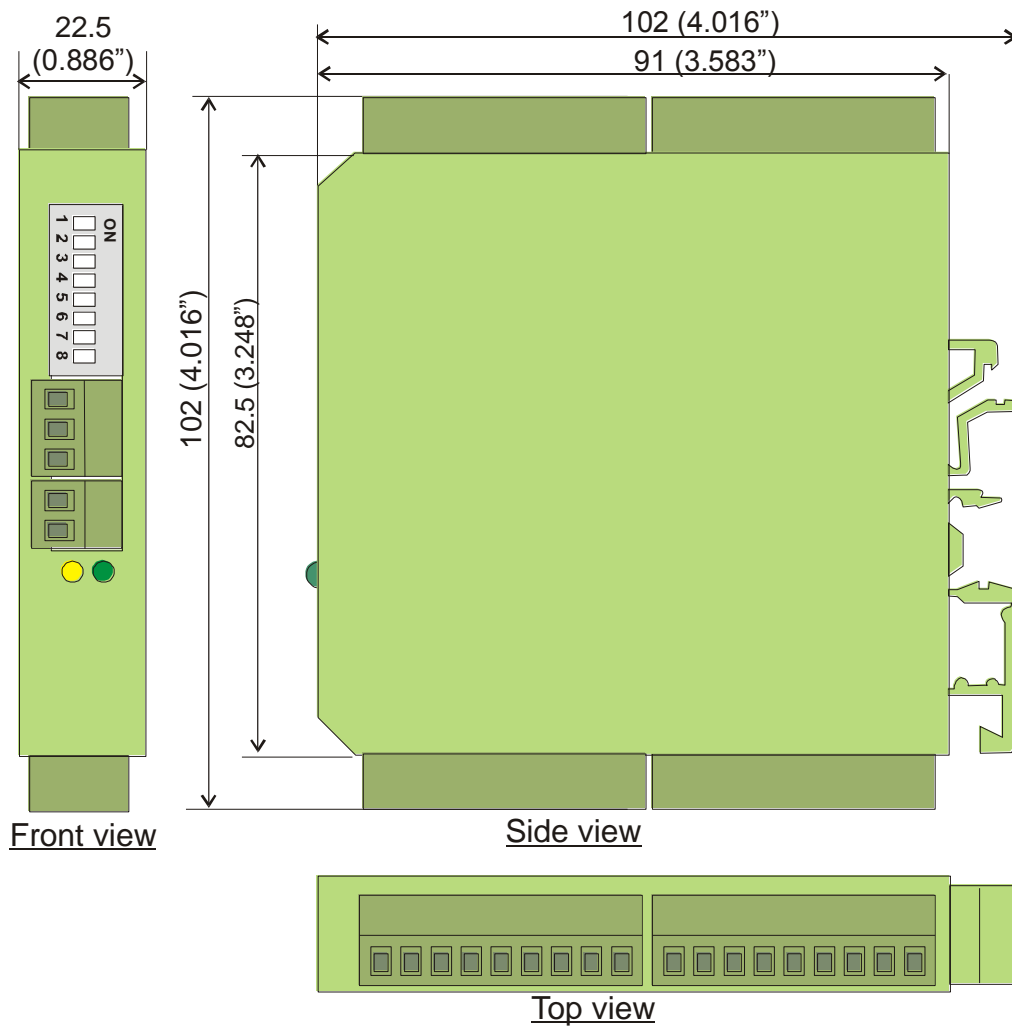

# 7. Technical Specifications

<b>Power supply:</b>	Input voltage: 12 ... 30 VDC Protection circuit: reverse polarity protection Ripple: $\leq 10\%$ at 24 VDC Consumption: approx. 50 mA (unloaded)
<b>Connections:</b>	Connector type: screw terminals, 1.5 mm <sup>2</sup> / AWG 16
<b>Encoder supply</b>	Output voltages: 5.2 VDC und 10 ... 28 VDC (app. 2 VDC lower than input voltage) Output current: max. 125 mA Protection: short-circuit proof
<b>Incremental inputs:</b>	Number of inputs: 2 Signal levels: adjustable to TTL / RS422 (differential signal > 1 V) or HTL (10 ... 30 V) Channels: symmetrical: A, /A, B, /B, Z, /Z asymmetrical: A, B, Z Frequency: symmetrical: max. 1 MHz asymmetrical: max. 250 kHz Internal resistance: $R_i \approx 4.7\text{ k}\Omega$
<b>Control inputs:</b>	Number of inputs: 2 Application: contactless and bounce-free signal switchover Levels: HTL, PNP (10 ... 30 V)
<b>Incremental outputs:</b>	Number of outputs: 2 Output level: adjustable to TTL / RS422 or HTL (12 ... 30 V, $\cong$ power supply voltage) Channels: A, /A, B, /B, Z, /Z Output current: RS422/TTL: 50 mA, HTL: max. 30 mA (per output) Output circuit: push-pull Signal propagation delay: approx. 600 ns Protection: short-circuit proof
<b>Housing:</b>	Material: plastic Mounting: 35 mm top hat rail (according to EN 60715) Dimensions: 22.5 x 102 x 102 mm (w x h x d) resp. 0.885 x 4.016 x 4.016 inch Protection class: IP20 Weight: approx. 100 g
<b>Temperature range:</b>	Operation: -20° - +60° C / -04° - +140° F (not condensing) Storage: -30° - +75° C / -22° - +167° F (not condensing)
<b>Failure rate:</b>	MTBF in years: 146.4 a (long-term usage at 60 °C / 140 °F)
<b>Conformity &amp; standards:</b>	EMC 2004/108/EC: EN 61000-6-2, EN 61000-6-3, EN 61000-6-4 Guideline 2011/65/EU: RoHS-conform