

## OPERATING INSTRUCTION

Prior to use, please read this manual thoroughly.

Keep this manual in a convenient place for quick and easy reference.

# Contents

• BEFORE USE .....	2P
• SUPPORT AND SERVICE .....	2P
- Customer support .....	2P
- Internet sales site .....	2P
- A/S regulation .....	2P
- Warranty regulation .....	2P
• BOX CONTENTS .....	2P 3P
• SAFETY NOTES .....	3P
• FEATURES .....	3P
• SPECIFICATION .....	4P
• TRANSMITTER CONTROL IDENTIFICATION .....	5P
• ADJUSTBLE STICK LENGTH .....	5P
• ADJUSTBLE STICK TESTION .....	5P
• WHAT IS HoTT .....	5P
• OPERATION .....	5P
1. Battery Installation .....	5P
2. Charging Batteries .....	5P
3. Turn on the transmitter .....	6P
4. Binding .....	6P
5. Servo Reversing .....	7P
6. Dual Rate .....	7P
7. Delta Wing .....	7P
8. 2 AILE .....	7~8P
9. V-Tail .....	7P
10. FailSafe .....	7~8P
11. RF Trainer .....	8P
12. Country setting .....	8~9P
13. Stick setting .....	9P
14. Range testing .....	9P
• ERROR .....	9P
• SMART BOX .....	9P
• FIRMWARE UPDATE .....	9P
• SAFETY APPROVAL .....	10~11p

## © BEFORE USE

Thank you for purchasing T5/mz-10 HoTT 2.4GHz Radio System. This system is extremely versatile and may be used by beginners and pros alike. In order for you to make the best use of your system and to fly safely, please read this manual carefully. If you have any difficulties while using your system, please consult the manual, our online Frequently Asked Questions (on the web pages referenced below), your hobby dealer, or the Graupner/SJ Service Center. Due to unforeseen changes in production procedures, the information contained in this manual is subject to change without notice.

## © SUPPORT AND SERVICE

- Customer support

Please contact your Graupner/SJ importer in your region of the world or visit "[www.openhobby.com](http://www.openhobby.com)" to assist you with any questions, problems or service needs.

- Internet sales site

Please feel free to contact "[www.openhobby.com](http://www.openhobby.com)" to get all information on product features, specifications, running events and the newest product line up.

- A/S regulation

Only when the product is faulty after normal operation within the warranty period, we will repair the product for free based on our regulations. The repair will be paid for by the consumer when the damage is due to use in improper ways or beyond the warranty period.

- Warranty regulation

Refer the WARRANTY CARD in a Package.

## © OPENHOBBY A/S CENTER

202 Dong- 201, Chunui Techno-Park II, 18, 198 street, Bucheon-ro, Wonmi-Gu,  
Bucheon-Shi, Gyungki-Do KOREA 420-857  
Phone: 82-70-7863-3672 Fax: 82-70-7863-3670  
Customer Service E-mail: [service@openhobby.com](mailto:service@openhobby.com)

## © BOX CONTENTS

- |                                   |                 |
|-----------------------------------|-----------------|
| • T5/mz-10/mz-10 HoTT Transmitter | • Charger       |
| • GR-12 6 Channel Receiver        | • WARRANTY CARD |
| • Manual                          | • Battery       |
| • Shunt connector                 |                 |

• NOTICE

All instructions, warranties and other collateral documents are subject to change at the sole discretion of Graupner/SJ. For up-to-date product literature, visit <http://www.openhobby.com> and click on the support tab for this product.



**WARNING**

Read the ENTIRE instruction manual to become familiar with the features of the product before operating. Failure to operate the product correctly can result in damage to the product, personal property and cause serious injury.

This is a sophisticated hobby product and NOT a toy. It must be operated with caution and common sense and requires some basic mechanical ability. Failure to operate this product in a safe and responsible manner could result in injury or damage to the product or other property. This product is not intended for use by children without direct adult supervision. Do not attempt disassembly, use with incompatible components or augment product in any way without the approval of Graupner/SJ. This manual contains instructions for safety, operation and maintenance. It is essential to read and follow all the instructions and warnings in the manual, prior to assembly, setup or use, in order to operate correctly and avoid damage or serious injury.

© SAFETY NOTES

- Do not fly your model near spectators, parking areas or any other area that could result in injury to people or damage of property.
- Ensure that all channels are working in the proper manner.
- Perform a ground range check prior to the initial flight of the day.
- The transmitter shouldn't be switched off at any time during flight.
- Don't move or touch the transmitter antenna during flight.
- Do not fly during adverse weather conditions. Poor visibility can cause disorientation and loss of control of your aircraft. Strong winds can cause similar problems.
- We strongly recommend to set the Failsafe function and also recommend that the preset Failsafe would be idle position.
- You need to set the function of the transmitter after removing a power battery from a model or stopping a engine of a model.
- Ensure that all your batteries have been properly charged prior to flight.
- We recommend to only to use adapter when you charge the battery of the transmitter and receiver.

© FEATURES

- 5 channels radio control set with Graupner/SJ HoTT 2.4 GHz technology(Hopping Intellective Telemetry)
- The use of up to 75 channels ensures extreme operating reliability and immunity to external interference.
- Real-Time Telemetry analysis.
- Displaying Telemetry data and programming receiver outputs with the optional Graupner/SJ Smart-Box and the optional sensors.
- Future-proof update capability using data interface.
- Advanced HoTT wireless trainer system makes Teacher and Pupil system more enjoyable and gives user convenience for the teaching/learning.
- Simple, ultra-fast binding of transmitter and receiver.
- Extremely fast re-binding, even at maximum range.

© SPECIFICATION

	Transmitter T5/mz-10	Receiver GR-12
Frequency band	2.4~2.4835GHz	2.4~2.4835GHz
Modulation	FHSS	FHSS
Output power	100mW	—
Current drain	Approx 125mA	Approx 70mA
Operating voltage	3.4V~6V	3.6V~8.4V



## © ADJUSTBLE STICK LENGTH

The control stick is consisted of 2pc of stick levers and it allows you to adjust the control stick's length as you want.

1. Hold the lever "B" and turn the lever "A" counter clockwise. The lock will be released.

2. Turn the lever "B" and adjust the control stick's length as you want. Turn the lever "A" clockwise, then the lever "A" and "B" are interlocked and fixed.

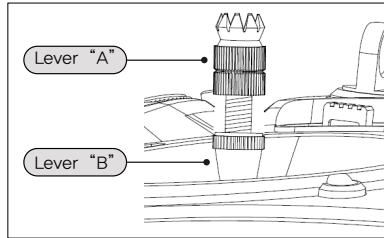

## © ADJUSTBLE STICK TENSION

The T5/mz-10 offers adjustable tension on the throttle, aileron, elevator and rudder sticks.

1. Remove the battery cover and battery from the transmitter.
2. Unscrew the six Philips head screws that hold the transmitter's rear cover and remove the rear case.
3. Using a Philips screw driver, adjust the stick tension screw for the desired control. Clockwise to tighten and counter clockwise to loosen.

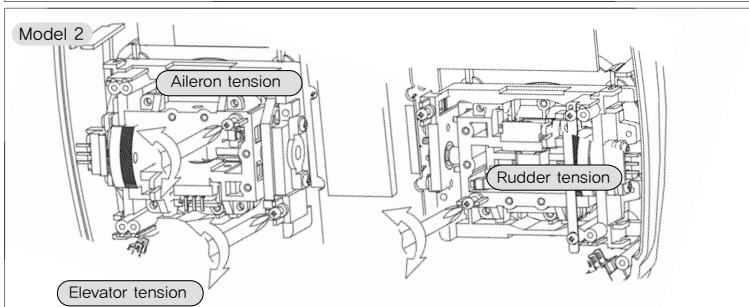
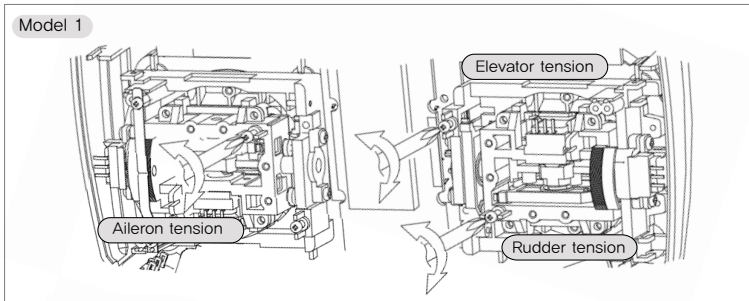

## © WHAT IS HoTT

HoTT stands for Hopping Sequence Telemetric Technology, it is Graupner/SJ's unique telemetry technology in 2.4GHz signal protocol that supports Bi directional data transmission gives user real-time information on things like user model's RPM, Voltage, Temperature, User programmed warning, and etc. The use of up to 75 channels ensures extreme operating reliability and immunity to external interference thanks to optimized frequency hopping broad channel sequence.



## © OPERATION

### 1. Battery Installation

Optional NiCd or NiMH 1.2-volt AA rechargeable 4-cell batteries can be used. A battery connector is on the inside of the transmitter for convenient recharging. Graupner/SJ offers rechargeable NiCd, NiMH batteries, part number S22331.

Remove the battery cover and install the battery pack ensuring the polarity of the battery connector.

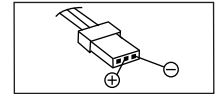

### 2. Charging Batteries

The included charger is designed to recharge your batteries at a rate of 150mA. Do not use this charger for equipment other than Graupner/SJ transmitters that use 4-cell battery packs. The charging plug polarity may not be the same and equipment damage can result. During the charging operation, the charger's temperature is slightly elevated. This is normal.

### ⚠ CAUTION

Charge only rechargeable batteries. Non-rechargeable batteries may burst causing injury to persons and/or damage to property. Never leave charging batteries unattended

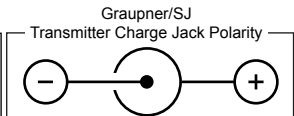

All Graupner/SJ charge jacks are center-pin negative. This is the opposite of many chargers. Before using a charger make sure the connector is center-pin negative. This can be done using a voltmeter. Also unlike conventional radio systems that use 8 cells to power the transmitter, the T5/mz-10 uses 4 cells. This is due to the electronics being more efficient. When charging, be sure to use a charger designed for a 4-cell 4.8-volt battery pack when charging the transmitter.

### 3. Turn on the transmitter

Leave the trainer switch to Normal position and turn on the transmitter.

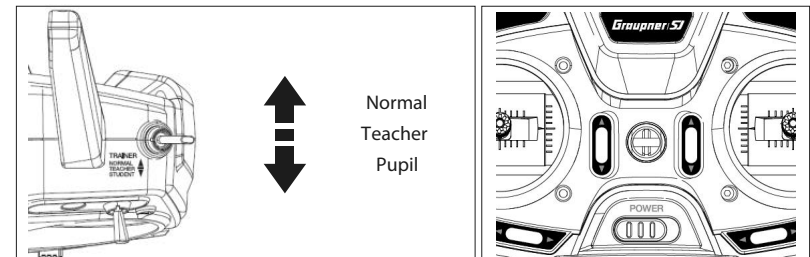

The T5/mz-10 is compatible with all current Graupner/SJ aircraft receivers (R Series)

#### 4. Binding

You must bind the receiver to the transmitter before the receiver will operate. Binding teaches the receiver the specific code of the transmitter so that it will only connect to its corresponding transmitter.

1. Switch on the transmitter and receiver.
2. Press & hold the SET button on the receiver for over 3 sec until the receiver enters BIND mode.
3. Press the MODE button on the transmitter, the system will be connected within a few seconds. Once connected, the bind LED on the transmitter will turn solid orange and the status LED on the receiver will turn solid green, indicating the receiver is bound to the transmitter. If the binding process has failed, repeat the whole procedure.

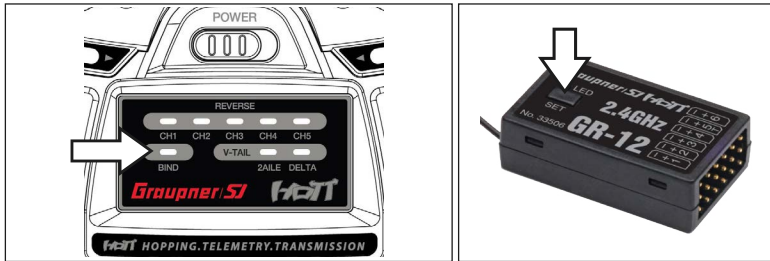

	LED before binding	LED after Binding
Transmitter	Orange LED Off	Orange LED On
Receiver	Green LED Off	Green LED On

#### 5. Servo Reversing

According to the LED status of each channel, you may check that the direction of servo rotation is in the normal or reverse, LED blinking means that direction of servo rotation is in the normal and LED turning on means that the direction of servo rotation is in the reverse.

1. Press & hold the DIRECTION button for over 2 sec and then release the button, the transmitter enters reverse mode and the LED of No. 1 channel blinks.
2. Press the MODE button, the LED of No. 1 channel goes solid and the direction of servo rotation is in the reverse.
3. Whenever you press the DIRECTION button, you may select the channel that you want and may set the direction of servo rotation in the same method above.
4. After setting servo reversing function, press & hold the DIRECTION button for over 2 sec and then release the button, now all servo reverse setting is stored to the transmitter.

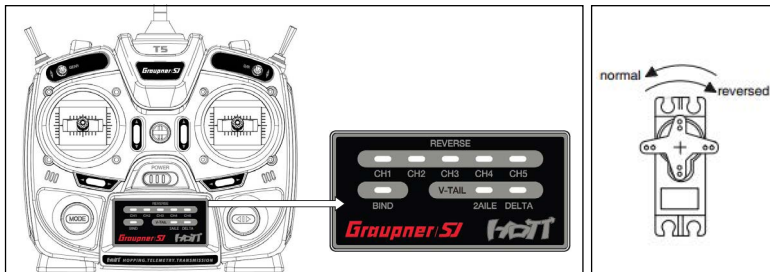

#### 6. Dual Rate

The T5/mz-10 offers a dual rate function on aileron, elevator and rudder. When the DUAL RATE SWITCH is in the up position, 100% travel is achieved on the aileron, elevator and rudder channels. When the switch is in the down position a reduced travel of 70% is achieved on the aileron, elevator and rudder channels. This is useful allowing the aircraft to have a high control rate (switch in the up position) for aggressive maneuvers and a low control rate (switch in down position) for smooth, precise maneuvers.

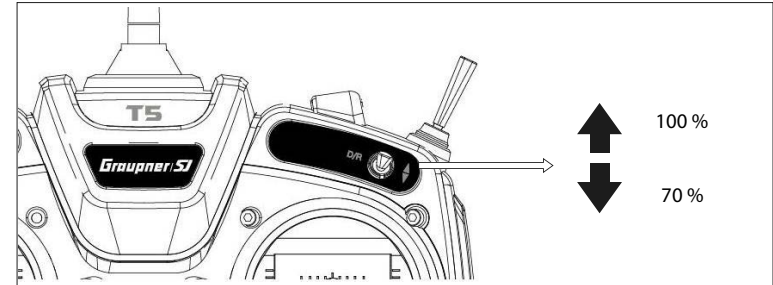

#### 7. Delta Wing

The T5/mz-10 offers a delta wing mix. delta wing mixing combines the function of ailerons with the function of the elevator to allow precise control of both roll and pitch for delta wing aircraft.

1. Press & hold the DIRECTION button for over 2 sec and then release the button, the transmitter enters Reverse mode.
2. Press the DIRECTION button repeatedly until the delta LED is on, then the transmitter enters delta mode. If delta mode is not set previously, the LED would blink.
3. Press the MODE button, the LED goes solid and delta wing function is activated.
4. After setting delta wing function, press & hold the DIRECTION button for over 2 sec and then release the button, the delta LED turns solid green, the delta wing setting is stored to the transmitter.

#### 8. 2 AILE

2 ailerons function is designed to allow more precise control. you may use 2 separate channels to control the left and right aileron

1. Press & hold the DIRECTION button for over 2 sec and then release the button to enter reverse mode.
2. Press the DIRECTION button repeatedly until the 2 aile LED is on, then the transmitter enters 2 aile mode. If 2 aile mode is not set previously, the LED would flash.
3. Press the MODE button, the LED goes solid and 2 aile function is activated.
4. After setting 2 aile function, press & hold the DIRECTION button for over 2 sec and then release the button, 2 aile LED turns solid green and 2 aile setting is stored to the transmitter.

#### 9. V-Tail

If the model features a V-tail instead of a conventional tail, you need to set V-tail.

1. Press & hold the DIRECTION button for over 2 sec and then release the button, the transmitter enters reverse mode.
2. After setting of delta and 2 aile according to above described procedure, press & hold the DIRECTION button for over 2 sec and then release the button. Delta LED and 2 aile LED go solid green together and V-tail function is activated. Delta LED and 2 aile LED are off after 5 seconds.

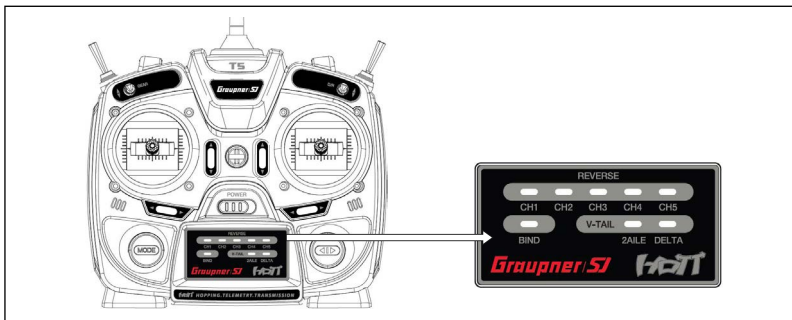

Function setting	LED	Description
DELTA	Green LED On	Delta wing function is activated, 2 Aile and V-tail functions are de-activated.
2 AILE	Green LED On	2 Aile function is activated, Delta and V-tail functions are de-activated.
DELTA and 2 AILE	2 Green LED On	V-tail function is activated, Delta and 2 aile functions are de-activated.

### ! NOTICE

You may select only 1 function of delta, 2 aile and V-tail  
When T5/mz-10 is switched on, the status LED of each function that you set is turned on for 5 seconds to indicate which function has been set.

## 10. FailSafe

When you bind your transmitter, you are programming the receiver with failsafe defaults. Graupner/SJ receiver has 4 Failsafe modes: FAILSAFE, HOLD, OFF and STANDARD.

1. Switch on the receiver and place transmitter RF TRAINER SWITCH at normal position. Press and hold the MODE button and switch on the transmitter. The Graupner/SJ logo repeat to blink a single red with a single beep, indicating that you entered the failsafe mode. Every time you press MODE button at failsafe mode, the 4 modes are changed in turns.

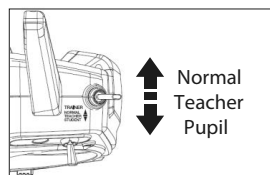

Button	Mode	LED status and beep
	FAILSAFE	Repeating that the Graupner/SJ logo blinks a single red with a single beep
Once	HOLD	Repeating that the Graupner/SJ logo blinks twice red with twice beeps
Once more	OFF	Repeating that the Graupner/SJ logo blinks three times red with three times beeps
Once more	STANDARD	Repeating that the Graupner/SJ logo blinks four times red with four times beeps

## 1-2. Failsafe mode

### - FAILSAFE

Move the control sticks on the transmitter to the desired preset failsafe positions. Press & hold the MODE button for over 2 sec and release the button. The Graupner/SJ logo turns solid red, indicating the failsafe mode has been set. Confirm the failsafe setting is correct by turning off the transmitter. The throttle should go to the preset position.

### - HOLD

Enter hold mode by pressing MODE button once from the failsafe mode. The Graupner/SJ logo repeats to blink twice red with twice beep. Press & hold the MODE button for over 2 sec and release the button. The Graupner/SJ logo turns solid red, indicating the hold mode has been set. If you lose connection, all channels hold the last given command.

### - OFF

Enter off mode by pressing MODE button once from the hold mode. The Graupner/SJ logo repeats to blink 3 times red with 3 times beep. Press & hold the MODE button for over 2 sec and release the button. The Graupner/SJ logo turns solid red, indicating the off mode has been set. Even if you lose connection, the failsafe is not working.

### - STANDARD

Enter standard mode by pressing MODE button once from the hold mode. The Graupner/SJ logo repeats to blink 4 times red with 4 times beep. Press & hold the MODE button for over 2 sec and release the button. The Graupner/SJ logo turns solid red, indicating the standard mode has been set. standard features that the throttle channel ( channel Number 1 ) is move into low throttle position and other channels hold last given command.

### ! NOTICE

Failsafe setting could be only set in case that RF TRAINER SWITCH is at normal flight position

## 11. RF Trainer

The T5/mz-10 has the trainer function. The function activates when you select Teacher, Pupil and Normal mode by RF TRAINER SWITCH.

### 1). Mode setting

#### 1-1. Teacher setting

Move transmitter's RF TRAINER SWITCH of the TEACHER transmitter to TEACHER position. Press & hold the MODE button and switch on the transmitter. The Graupner/SJ logo repeats to blink twice red with twice beeps, indicating that you set TEACHER Mode. After two beeps sound twice, two beeps don't sound. Now the T5/mz-10 can bind and control all channels of the pupil's transmitter without restriction.



## 1-2. Pupil setting

When using the T5/mz-10 as the pupil transmitter, bind the receiver at the NORMAL mode first. Turn off the transmitter, and still the receiver is turned on, and move transmitter's RF TRAINER SWITCH to PUPIL position. Press & hold the MODE button and switch on the transmitter. The Graupner/SJ logo repeats to blink a single red with a single beep, indicating that you set PUPIL Mode. After one beep sound twice, a beep doesn't sound. Now the Teacher's transmitter can bind and control all channels of the T5/mz-10 without restriction.

## 1-3. Normal setting

Getting back to the NORMAL mode from TEACHER or PUPIL mode, move transmitter's RF TRAINER SWITCH to NORMAL position. Press & hold the MODE button and switch on the transmitter then the transmitter enters the failsafe mode automatically. The Graupner/SJ logo repeats to blink a single red with a single beep. Turn off the transmitter then the NORMAL setting is completed.

### NOTICE

After completing the normal setting, Graupner/SJ logo turns solid red in the General mode and blinks red in the France mode.  
Teacher setting: The Graupner/SJ logo repeats to blink twice red, 2 beeps sounds twice.  
Pupil setting: The Graupner/SJ logo repeats to blink a single red, 1 beep sounds twice.

## 2). Trainer Operation

- 2 - 1. Move transmitter's RF TRAINER SWITCH to NORMAL position. Bind the pupil transmitter to the pupil receiver.
- 2 - 2. Set the transmitter to PUPIL mode, the connection would be lost between the transmitter and receiver.
- 2 - 3. Set the another transmitter to TEACHER mode.
- 2 - 4. Press & hold the MODE button of the pupil transmitter until the beep first and then press & hold the MODE button of the teacher transmitter until the beep as well. Now the teacher transmitter to pupil transmitter has been bound. The teacher transmitter can control all channels and if RF TRAINER SWITCH of the teacher transmitter would be moved to PUPIL position, the pupil transmitter can control all channels.

## 12. Country setting

The T5/mz-10 offers 2 modes of GENERAL and FRANCE. You need the France RF setting to comply with France regulations in FRANCE. France RF setting should only be turned on when operating your transmitter in France outdoors.

1. Insert the supplied shunt connector into the DATA socket at the back of the transmitter and switch on the transmitter, The Graupner/SJ logo turns solid red with a single beep, indicating that the country setting is in GENERAL mode that is preset at the factory.
2. Press MODE button, The Graupner/SJ logo blinks red with twice beeps, indicating that the country setting is in FRANCE mode.
3. Press MODE button for over 2 sec, France RF setting is completed with a beep, you don't need the country setting of the receiver.



### NOTICE

After completing the country setting, the shunt connect should be detached.

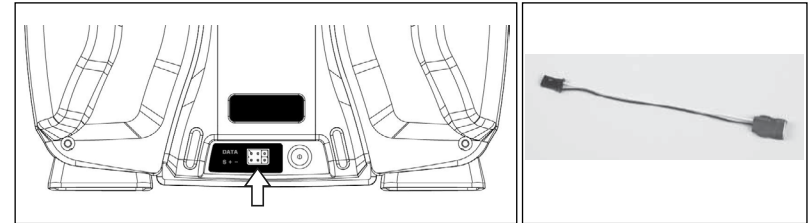

## 13. Stick setting

The T5/mz-10 has four stick modes of a fixed wing model on the two dual axis sticks. The primary functions are aileron, elevator, rudder and throttle (or airbrakes).

1. Enter the France mode in country setting after Insert the supplied shunt connector into the data socket at the back of the transmitter.
2. Press MODE button once more, The Graupner/SJ logo blinks red with 3 times beeps, indicating that the stick setting is in the stick mode 1 that is preset at the factory. Each time you press MODE button, the beep is increased one at a time and the mode is changed in turns.
3. After selecting the desired the stick mode, press MODE button for over 2 sec, the Stick setting is completed with a beep.



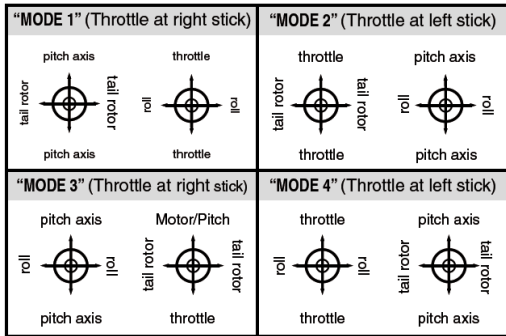

Beep	Graupner/SJ logo	Mode	Description
1 time	Solid red	Country setting	GENERAL
2 times	Blink red	Country setting	FRANCE
3 times	Solid red	Stick setting	STICK mode 1
4 times	Solid red	Stick setting	STICK mode 2
5 times	Solid red	Stick setting	STICK mode 3
6 times	Solid red	Stick setting	STICK mode 4

### ! NOTICE

After completing the country setting, the shunt connect should be detached.

## 14. Range testing

Before each flying session, especially with a new model, it is important to perform a range check. The T5/mz-10 incorporates a range testing mode which reduces the output power of the transmitter, allowing a range check.

1. With the model restrained on the ground, face the model with the transmitter in your normal flying position.
2. After binding the transmitter to the receiver, press & hold BIND button until entering the range testing mode. The beep is repeated for 90 seconds in the range testing mode.
3. Walk over 50 meters away from the model with controlling the transmitter sticks constantly and check whether the model is operating normally. You should have total control of the model with the trainer switch pulled.
4. If control issues exist within 50 meters, the system should not be used. And contact your local Service Department of Graupner/SJ.

### © ERROR

- The signal reception of the receiver is not good  
The transmitter repeats that Graupner/SJ logo blinks 3 times red with 3 times beeps.
- The signal reception of the transmitter is not good  
The transmitter repeats that Graupner/SJ logo blinks 4 times red with 4 times beeps.
- Battery low voltage alarm  
When the battery voltage drops below 4.5 volts, the transmitter repeats that Graupner/SJ logo blinks 5 times red with 5 times beeps. When using the smart box, the alarm range could be set 4.0V ~15.0V

### © SMART BOX

When using the optional smart box, the transmitter's functions can be easy to set up and check the telemetry data. Connect into the DATA socket at the back of the transmitter and switch on the transmitter.

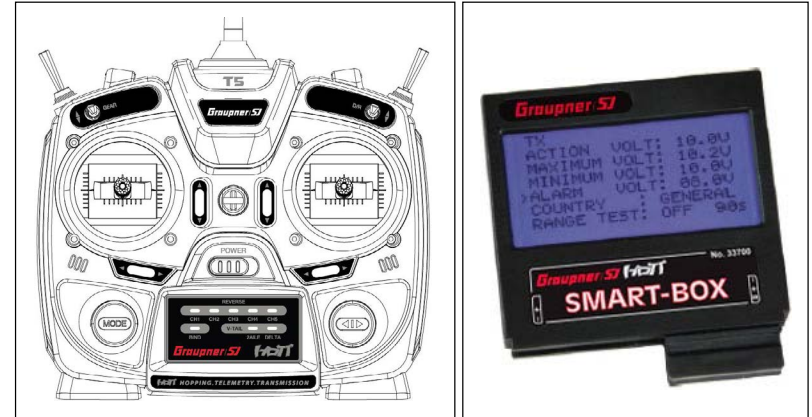

- The display of the smart box

- ALARM VOLT : Battery low voltage alarm
- COUNTRY : Country setting
- RANGE TEST : ON, OFF

```

TX
ACTION VOLT : 05.9V
MAXIMUM VOLT : 08.0V
MINIMUM VOLT : 05.9V
ALARM VOLT : 04.0V
COUNTRY : GENERAL
RANGE TEST: OFF 90s
  
```

### © FIRMWARE UPDATE

For more information on the latest firmware and the related software, please refer to the download menu on our website [www.openhobby.com](http://www.openhobby.com), [www.graupner-sj.com](http://www.graupner-sj.com)  
NOTICE: The optional USB adapter is needed to update.

Declaration of Conformity

(in accordance with ISO/IEC 17050-1)



- Product(s): Graupner/SJ T5/mz-10/mz-10 Transmitter

Item Number(s):

Equipment class: 2

The objects of declaration described above are in conformity with the requirements of the specifications listed below, following the provisions of the European R&TTE directive 1999/5/

EC:

**EN 62479:2010**

**EN 60950-1:2006/A11:2009/A1:2010/A12:2011**

**EN 301 489-1 V1.9.2**

**EN 301-489-17 V2.2.1**

**EN 300 328 V1.7.1**



• **FCC Information**

- Graupner /SJ T5/mz-10/mz-10 Transmitter



**Contains FCC ID: SNL-36204210**

**FCC 47 CFR PART 15C**

• **FCC Statement**

1. This device complies with Part 15 of the FCC Rules. Operation is subject to the following two conditions:
  - (1) This device may not cause harmful interference.
  - (2) This device must accept any interference received, including interference that may cause undesired operation.
2. Changes or modifications not expressly approved by the party responsible for compliance could void the user's authority to operate the equipment.

• **NOTE**

This equipment has been tested and found to comply with the limits for a Class B digital device, pursuant to Part 15 of the FCC Rules. These limits are designed to provide reasonable protection against harmful interference in a residential installation. This equipment generates uses and can radiate radio frequency energy and, if not installed and used in accordance with the instructions, may cause harmful interference to radio communications. However, there is no guarantee that interference will not occur in a particular installation. If this equipment does cause harmful interference to radio or television reception, which can be determined by turning the equipment off and on, the user is encouraged to try to correct the interference by one or more of the following measures:

- Reorient or relocate the receiving antenna.
- Increase the separation between the equipment and receiver.
- Connect the equipment into an outlet on a circuit different from that to which the receiver is connected.
- Consult the dealer or an experienced radio/TV technician for help.

• **FCC radiation exposure statement**

This equipment complies with FCC radiation exposure limits set forth for an uncontrolled environment. This equipment should be installed and operated with minimum distance of 20 cm between the radiator and your body.

• **KC Information**

- Graupner /SJ T5/mz-10/mz-10 Transmitter

- KCC인증번호: KCC-RRM-sjr-16005000, KCC-CRM-sjr-36204210

- 방송통신위원회고시 제2013-01호 "무선설비규칙"

- 방송통신위원회고시 제2012-102호 "신고하지 아니하고 개설할 수 있는 무선기기"

**KN 301 489-1:2009**

**KN 301 489-17:2009**

**KN 61000-4-2:2008**

**KN 61000-4-3:2011**



- **Caution**

- This equipment's aerial must be at least 20 cm from any person when the system is in use. We therefore do not recommend using the equipment at a closer range than 20cm.
- Ensure that no other transmitter is closer than 20cm from your equipment, in order to avoid adverse effects on the system's electrical characteristics and radiation pattern.
- The radio control system should not be operated until the Country setting has been set correctly at the transmitter. This is essential in order to fulfill the requirements of various directives - FCC, ETSI, CE, KC and etc. Please refer to the instructions for your particular transmitter and receiver for details of this procedure.
- Check all working systems and carry out at least one full range check on the ground before every flight, in order to show up any errors in the system and the models programming.
- Never make any changes to the programming of the transmitter or receiver whilst operating a model.

- **ENVIRONMENTAL PROTECTION NOTES**

This product must not be disposed of with other waste. Instead, it is the user's responsibility to their waste equipment by handing it over to a designated collection point for the recycling of waste electrical and electronic equipment. The separate collection and recycling of your waste equipment at the time of disposal will help to conserve natural resources and ensure that it is recycled in a manner that protects human health and the environment. For more information about where you can drop off your waste equipment for recycling, please contact your local city office, your household waste disposal service or where you purchased the produce

