

Linear actuator DSZY1-Potentiometer

Electric linear actuators are used in many different applications.

DSZY1-potentiometer is equipped with a rugged acme screw with high static force. It is a small, compact and lightweight dc-linear drive.

Internal diodes allow the easy change of direction by reversing the power-supply. All DSZY1-actuators have two end-switches integrated (not possible to adjust).

An overload-protection can be made by using a current control.



Model code

DSZY1	-	12	-	10	-	200	-	POT - IP65
Type		Voltage		Gear reduction		Stroke		Protection type
		12V 24V		5 10 20 30 40		25mm 50mm 100mm 150mm 200mm 250mm 300mm		

Diagram

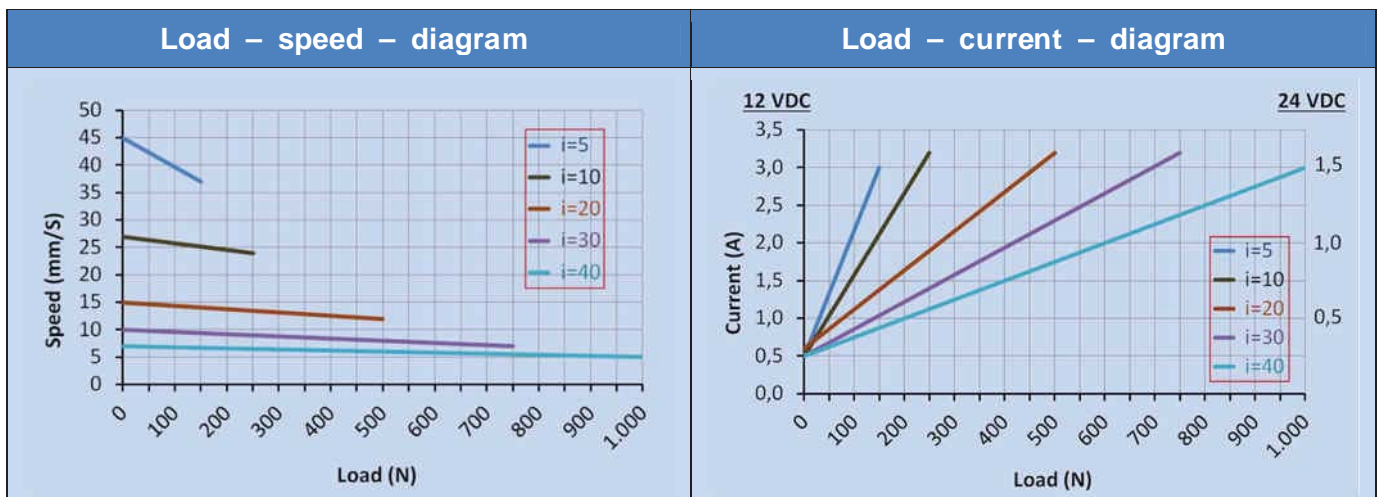

Additional technical data

- push/pull force: up to 1000N
- Zinc alloy housing
- Potentiometer
- static force: 2000N (by i=40)
- Aluminium outer tube and stroke rod
- Protection type: IP65
- Operating temperature : -26C°- 65C°
- Voltage: 12 or 24 VDC
- Duty cycle: 25%

Dimension

Linear actuator	Length	Mass in mm						
	Stroke	25	50	100	150	200	250	300
DSZY1 - type potentiometer	A	165	195	246	297	348	399	450
	B	190	245	346	447	548	649	750
	Poti-resistance KOhm		0,3-9,3	0,3-9,7	0,3-8,6	0,3-9,6	0,3-9,3	0,3-9,3

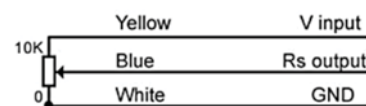
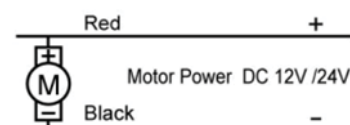
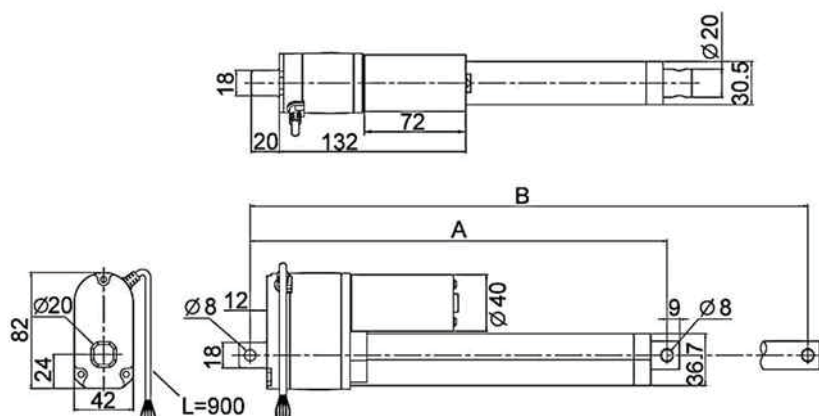

<p>C1x Hole $\varnothing 8$</p>	C1x – is standard	<p>Clamp Mounting Bracket</p>
<p>$\varnothing 8$ C2x Plastic Connector</p>	Options: C2x or C3x	
<p>$\varnothing 8$ C3x Universal Joint</p>	<p>Attention: By C3x - the dimension A and B lengthens itself about +41mm</p>	

Mounting für actuator

Clamp: DSZY1-H01

Mounting Bracket: DSZY1-H02

Please additionally order.

Mounting instruction

Please make sure, that load is not bigger than shown in the diagram speed/load. If overload is possible in the application, please use a separate current control to switch off at too high current (= too high load). Nominal current, depending on ratio, is shown in the diagram current / load.

Please use the right voltage supply as it is shown on the actuator. For extending the piston rod connect the red cable with plus and the black cable with minus. Movement is stopped automatically at the end of the stroke. For moving back, reverse the polarity (change plus and minus). Endswitches are not adjustable by themselves.

Load should be centered in moving direction, shear forces should be avoid because of shortening the lifetime. Big shear forces can destroy the actuator! Be carefull.

	<p>Drive-System Europe Ltd.</p>	<p>www.drive-system.com engineering@drive-system.com</p>
--	---------------------------------	--