

RoHS Compliant

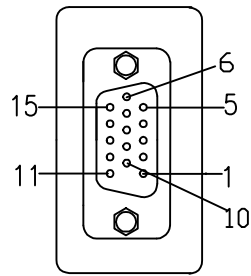

VGA15M

P1

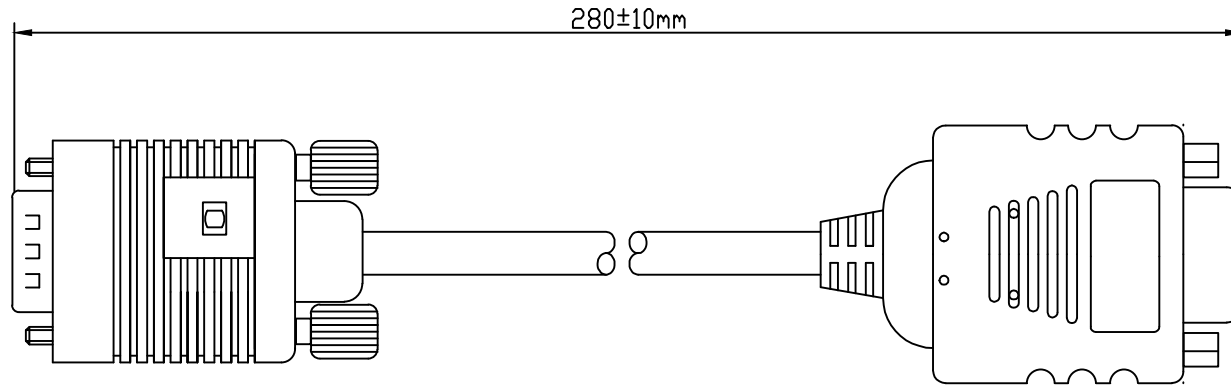
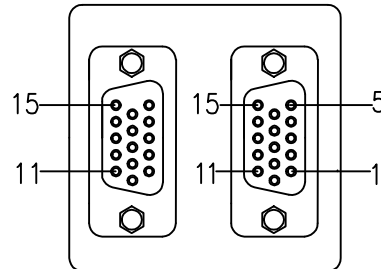

VGA15F VGA15F

P2 P3

Pin Assignment

| P1 | P2 | P3 |
|-------|-------|-------|
| 1 | 1 | 1 |
| 2 | 2 | 2 |
| 3 | 3 | 3 |
| 4 | 4 | 4 |
| 5 | 5 | 5 |
| 6 | 6 | 6 |
| 7 | 7 | 7 |
| 8 | 8 | 8 |
| 9 | 9 | 9 |
| 10 | 10 | 10 |
| 11 | 11 | 11 |
| 12 | 12 | 12 |
| 13 | 13 | 13 |
| 14 | 14 | 14 |
| 15 | 15 | 15 |
| SHELL | SHELL | SHELL |

Electronic Test:

- 1.100% TEST OPEN SHORT MIS-MIRE
- 2.CONTANCT RESISTANCE:3Ω
- 3.INSULATION RESISTANCE:5MΩ
- 4.HIE-POT:300V DC/10MS

| NUMBER | PRODUCT SPECIFICATIONS | Quantity | Unit |
|--------|--|----------|------|
| 4 | 45P PVC BLACK | | G |
| 3 | CONNECTOR:VGAF*2PCS.(GOLD PLATED,BLACK INSULATION) | | PCS |
| 2 | CONNECTOR:VGAM*1PCS (GOLD PLATED,BLACK INSULATION) | 1 | PCS |
| 1 | CABLE:28AWG*15C+AD+AL OD8.0mm BLACK 25CM | 1 | PCS |

| | | |
|-------|--------|------|
| D | | |
| C | | |
| B | | |
| VER.A | REVISE | DATE |

| | | |
|----------|-------------|------------------|
| Item | | |
| Draw | <i>Andi</i> | Date: 2015.07.10 |
| Approval | | |
| Maker | F16 | |