

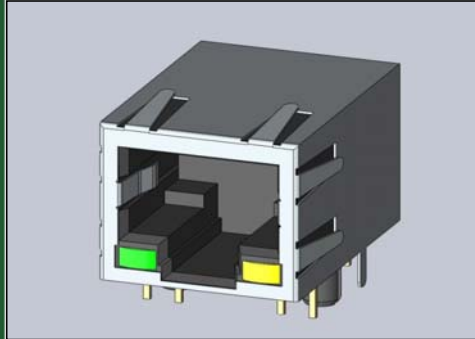

# STANDARD RJ45 MAGNETIC JACKS

## SERIES A60



### Description:

• Magnetic jacks are integrated connectors that combine network magnetics with RJ 45 modular jack connectors. Magnetic jacks combine connectivity with signal conditioning, electro magnetic interference suppression and signal isolation. These parameters were previously performed by separate and discrete magnetic components mounted on the PCB board.

• Available as single or stacked multiport options they are used in Data, Telecom, Networking and Home Entertainment markets for applications such as Servers, Hubs, Routers, Printers, Computers, Set Top Boxes and Digital TV's.

• MATE WITH MODULAR PLUG CONFORMING TO FCC PART 68, SUBPART F.

### Features:

- 10/100 or 1000 Base T options – Full IEEE 802.3 compliance
- Integrated Magnetics – Provides signal integrity, DC isolation and protection for PHY chip
- Integrated Design - Reduces component inventory and process costs
- Spring fingers on shells - Guaranteed advanced EMI/RFI suppression
- LED options available - Visual indication of port status and activity information for user
- Tab Up or Down options - Complete design for board and unit compatibility

### Example Part Number:

A60-142-200P431

#### SERIES:

A60 - 10/100/1000 BASE T, 8 CORE  
 A61 - 10/100/1000 BASE T, 12 CORE  
 A62 - 10/100 BASE T, 2 CORE  
 A63 - 10/100 BASE T, 4 CORE  
 A64 - 10/100 BASE T, 5 CORE  
 A65 - 10 BASE T, 3 CORE  
 A66 - 10 BASE T, 4 CORE  
 A67 - 10/100 BASE T, POE  
 A68 - 10/100 BASE T WITH USB TYPE A

#### NO. OF PORTS: 1 4

STACK SIZE PORT PER STACK  
 11 - 1X1: 1 PORT, 21 - 2X1: 2 PORTS  
 12 - 1X2: 2 PORTS, 22 - 2X2: 4 PORTS  
 14 - 1X4: 4 PORTS, 24 - 2X4: 8 PORTS  
 16 - 1x6: 6 PORTS, 26 - 2x6: 16 PORTS

#### CONTACT PLATING:

2 - GOLD FLASH  
 3 - 15 MICROINCHES OF GOLD  
 4 - 30 MICROINCHES OF GOLD

#### CONNECTOR TYPE:

2 - RIGHT ANGLE WITH TAB-UP  
 3 - RIGHT ANGLE WITH TAB-DOWN  
 4 - VERTICAL WITH TAB-UP  
 5 - VERTICAL WITH TAB-DOWN  
 6 - SMT WITH TAB-UP  
 7 - SMT WITH TAB-DOWN  
 8 - RIGHT ANGLE WITH TAB-UP AND PANEL STOP  
 9 - RIGHT ANGLE WITH TAB-DOWN AND PANEL STOP  
 A - VERTICAL WITH TAB-UP AND PANEL STOP

#### ELECTRICAL CIRCUIT TYPE:

(SEE CIRCUIT TYPE PAGE FOR DETAILS)

#### SHIELD TYPE:

0 - NO SHIELD  
 1 - SHIELDED, NO EMI FINGER  
 2 - SHIELDED, WITH EMI FINGER ON TOP  
 3 - SHIELDED, WITH EMI FINGER BOTH SIDES  
 4 - SHIELDED, WITH EMI FINGER ON THREE SIDES  
 5 - SHIELDED, WITH EMI FINGER ON FOUR SIDES

#### HOUSING MATERIAL:

P - PBT POLYESTER  
 N - NYLON POLYESTER

#### RIGHT LED COLOR:

0 - NO LED  
 1 - YELLOW  
 2 - RED  
 3 - GREEN  
 4 - ORANGE  
 5 - GREEN/YELLOW BI-COLOR  
 6 - RED/GREEN BI-COLOR  
 7 - GREEN/ORANGE BI-COLOR  
 8 - RED/YELLOW BI-COLOR  
 9 - ORANGE/YELLOW BI-COLOR  
 A -

#### LEFT LED COLOR:

0 - NO LED  
 1 - YELLOW  
 2 - RED  
 3 - GREEN  
 4 - ORANGE  
 5 - GREEN/YELLOW BI-COLOR  
 6 - RED/GREEN BI-COLOR  
 7 - GREEN/ORANGE BI-COLOR  
 8 - RED/YELLOW BI-COLOR  
 9 - ORANGE/YELLOW BI-COLOR  
 A -



EDAC INC  
TORONTO, ONTARIO  
CANADA

YOUR CONNECTION TO QUALITY & SERVICE

# STANDARD RJ45 MAGNETIC JACKS ELECTRICAL CIRCUIT TYPE

## 11 TYPE

CONNECTOR SOLDER SIDE

RJ45 CONTACT SIDE

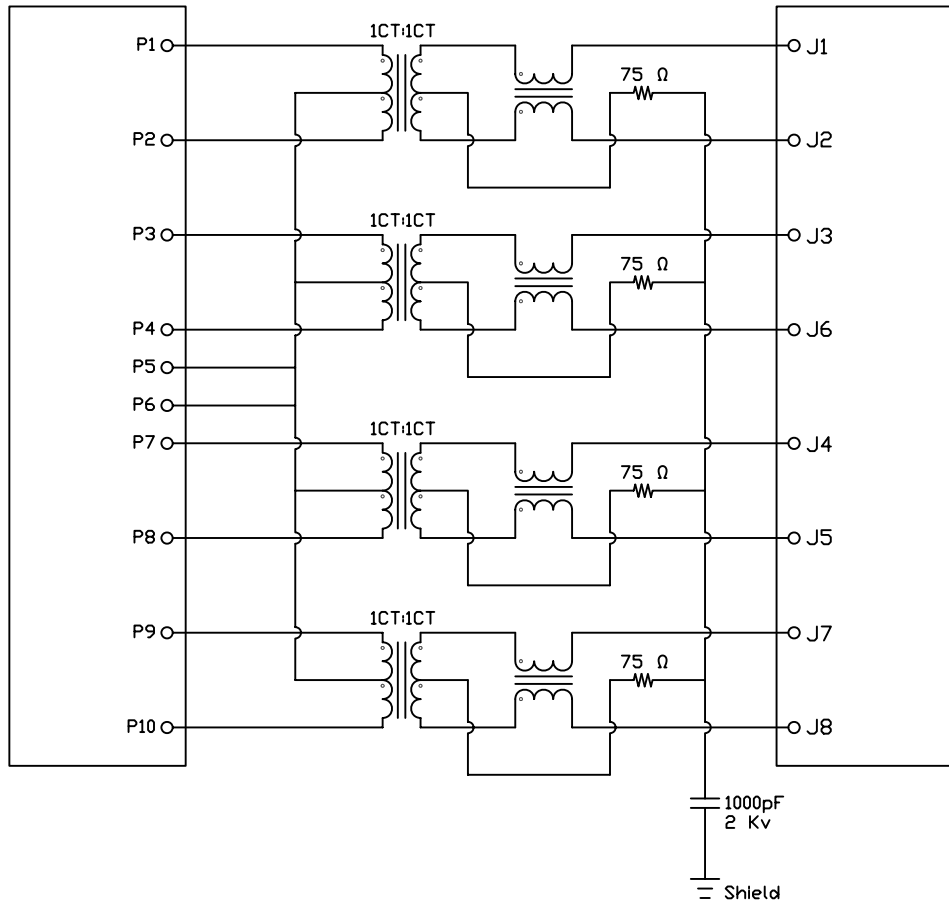

## 14 TYPE

CONNECTOR SOLDER SIDE

RJ45 CONTACT SIDE

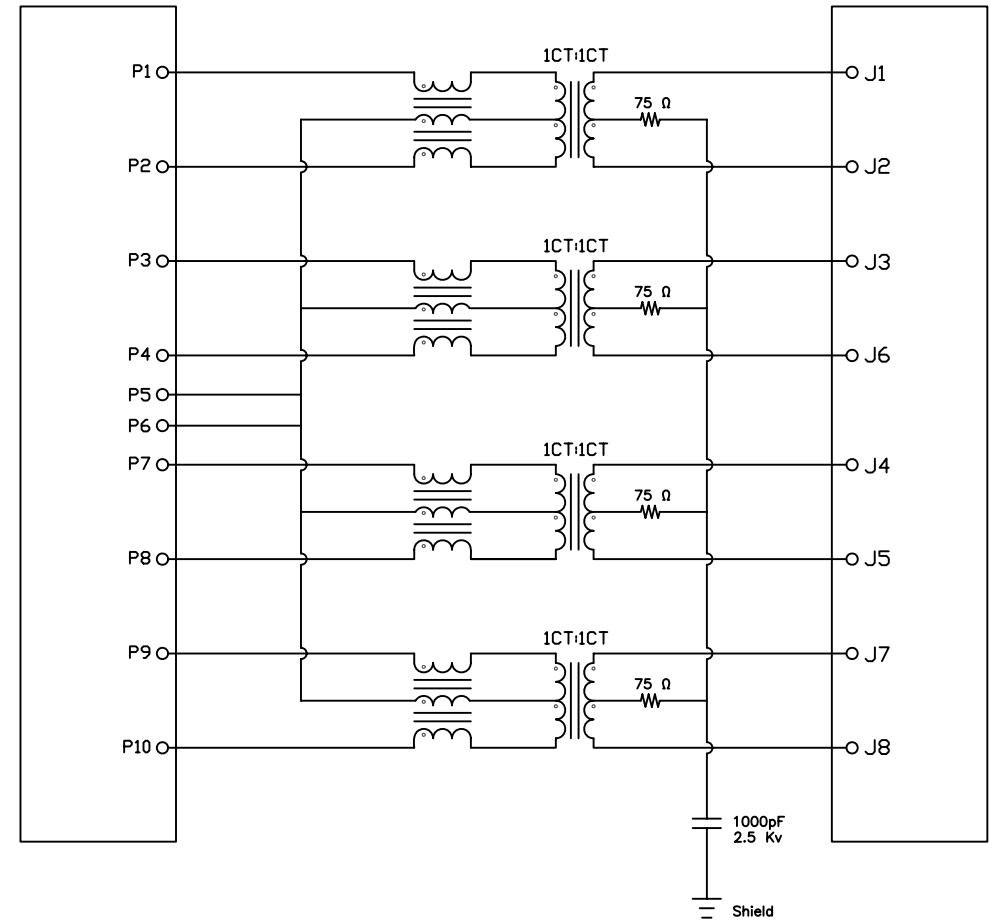



EDAC INC  
TORONTO, ONTARIO  
CANADA

YOUR CONNECTION TO QUALITY & SERVICE

# STANDARD RJ45 MAGNETIC JACKS ELECTRICAL CIRCUIT TYPE

## 32 TYPE

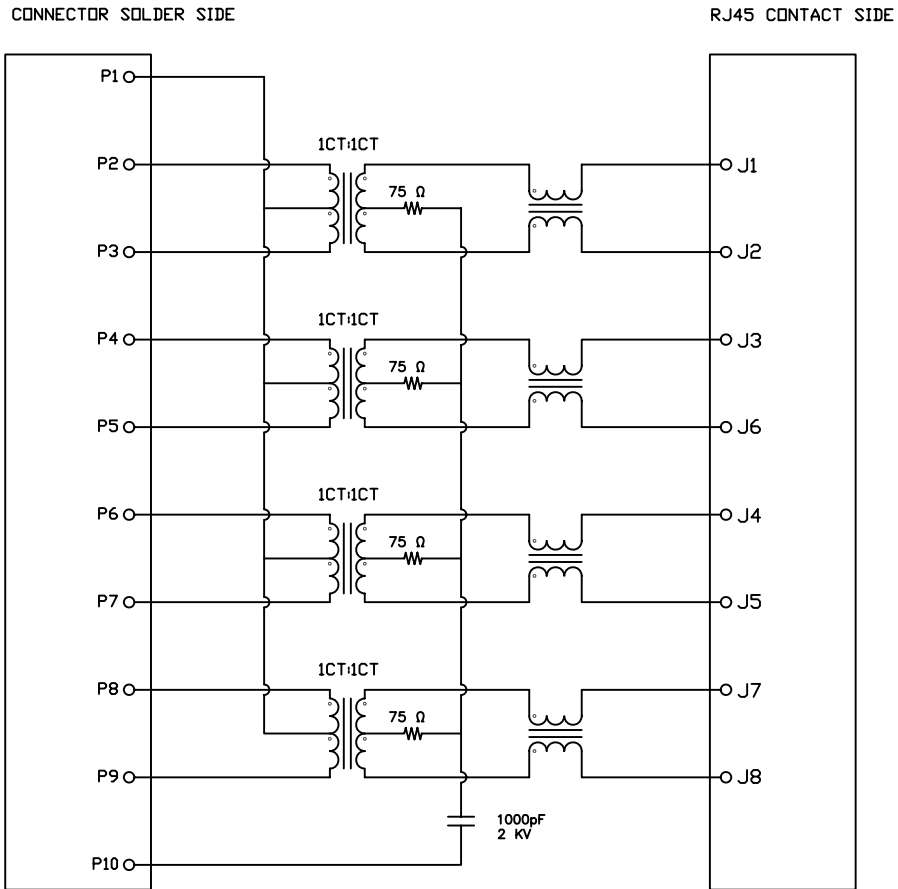

## 21 TYPE

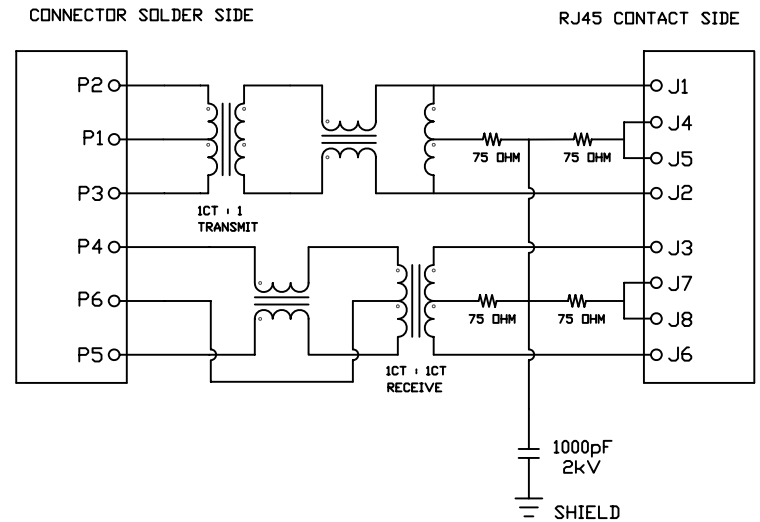

## 22 TYPE

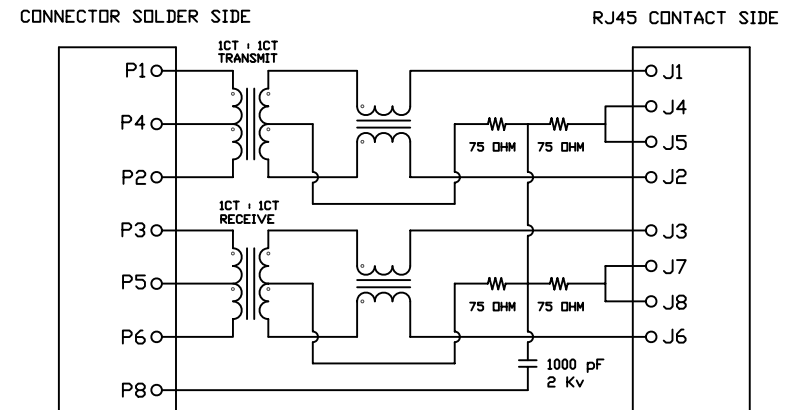



EDAC INC  
TORONTO, ONTARIO  
CANADA

YOUR CONNECTION TO QUALITY & SERVICE

# STANDARD RJ45 MAGNETIC JACKS ELECTRICAL CIRCUIT TYPE

## 31 TYPE

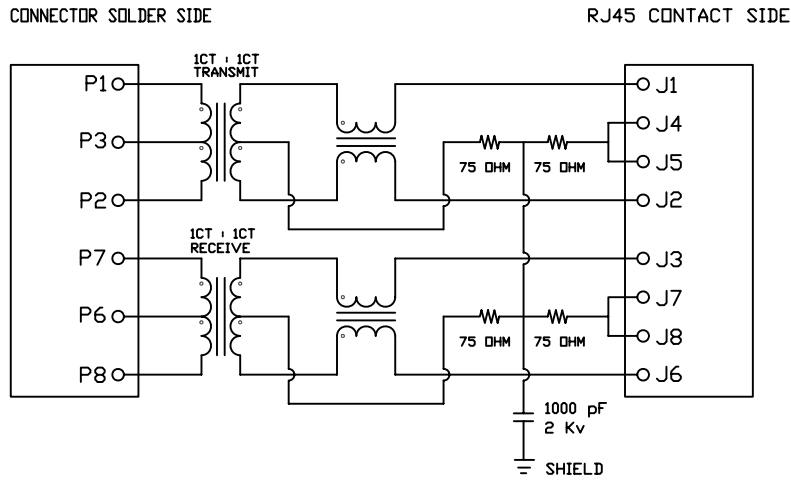

## 61 TYPE

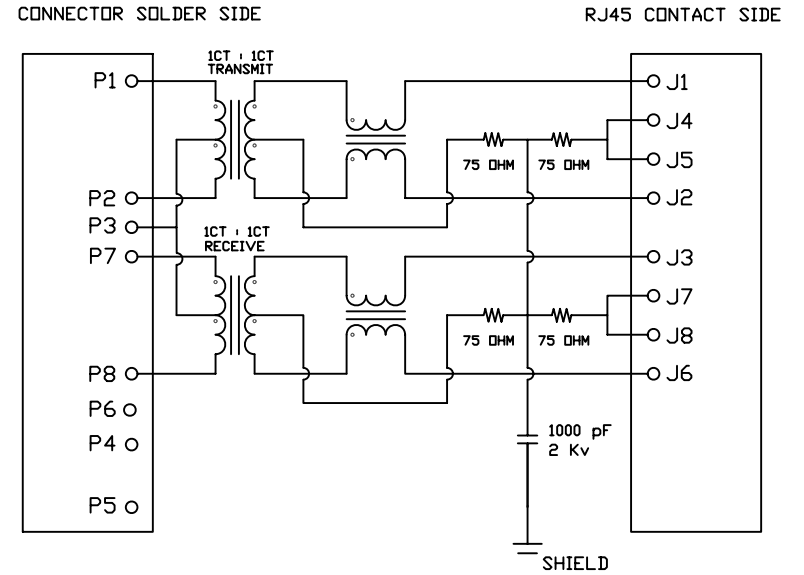

## 35 TYPE

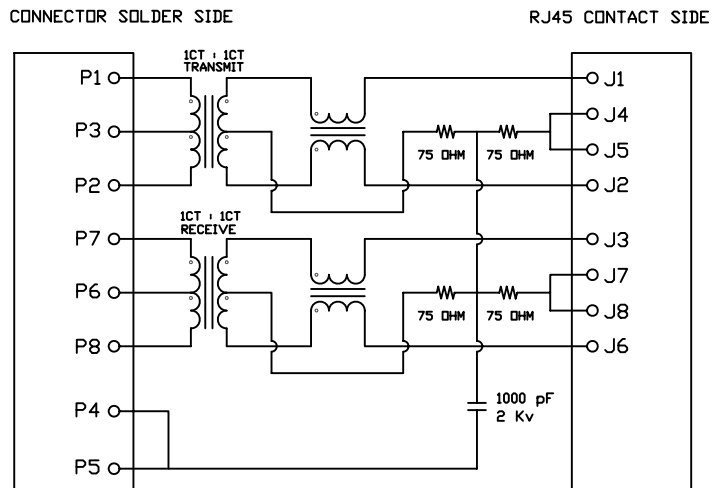

## 91 TYPE

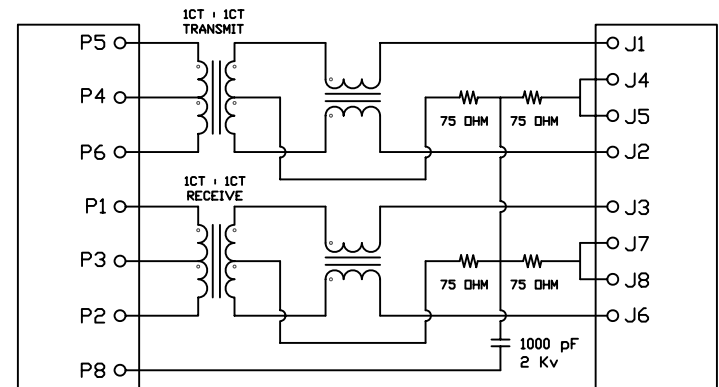



EDAC INC  
TORONTO, ONTARIO  
CANADA

YOUR CONNECTION TO QUALITY & SERVICE

# STANDARD RJ45 MAGNETIC JACKS ELECTRICAL CIRCUIT TYPE

## 62 TYPE

CONNECTOR SOLDER SIDE

RJ45 CONTACT SIDE

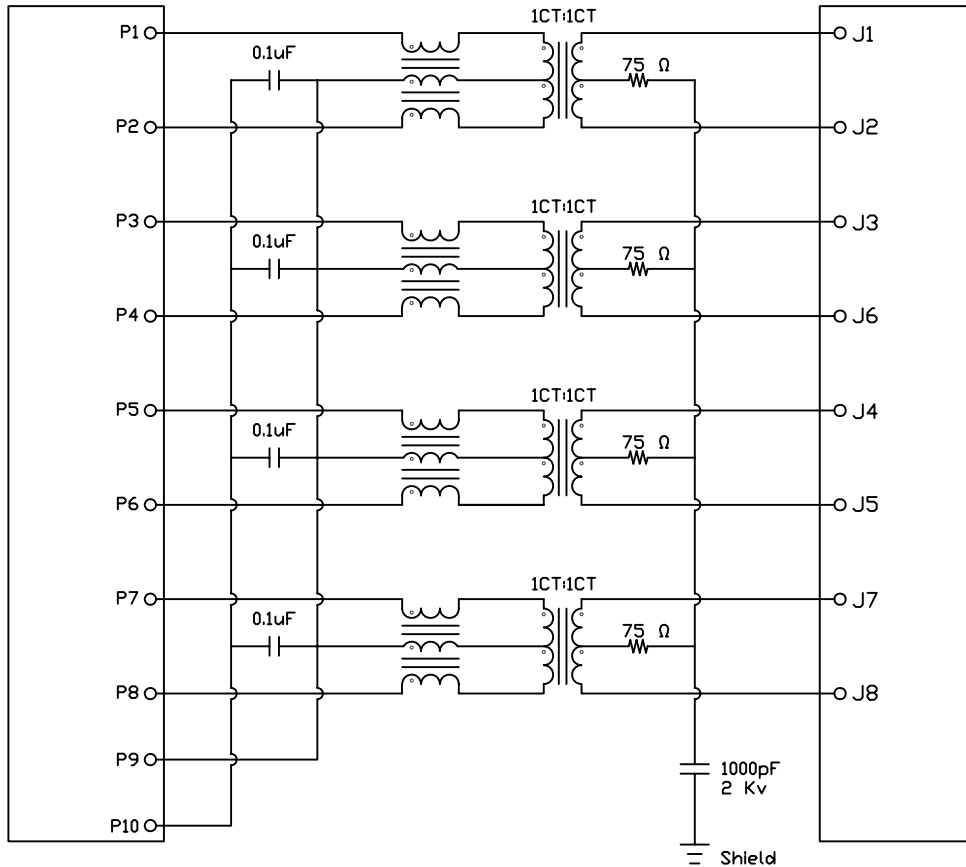

## 71 TYPE

CONNECTOR SOLDER SIDE

RJ45 CONTACT SIDE

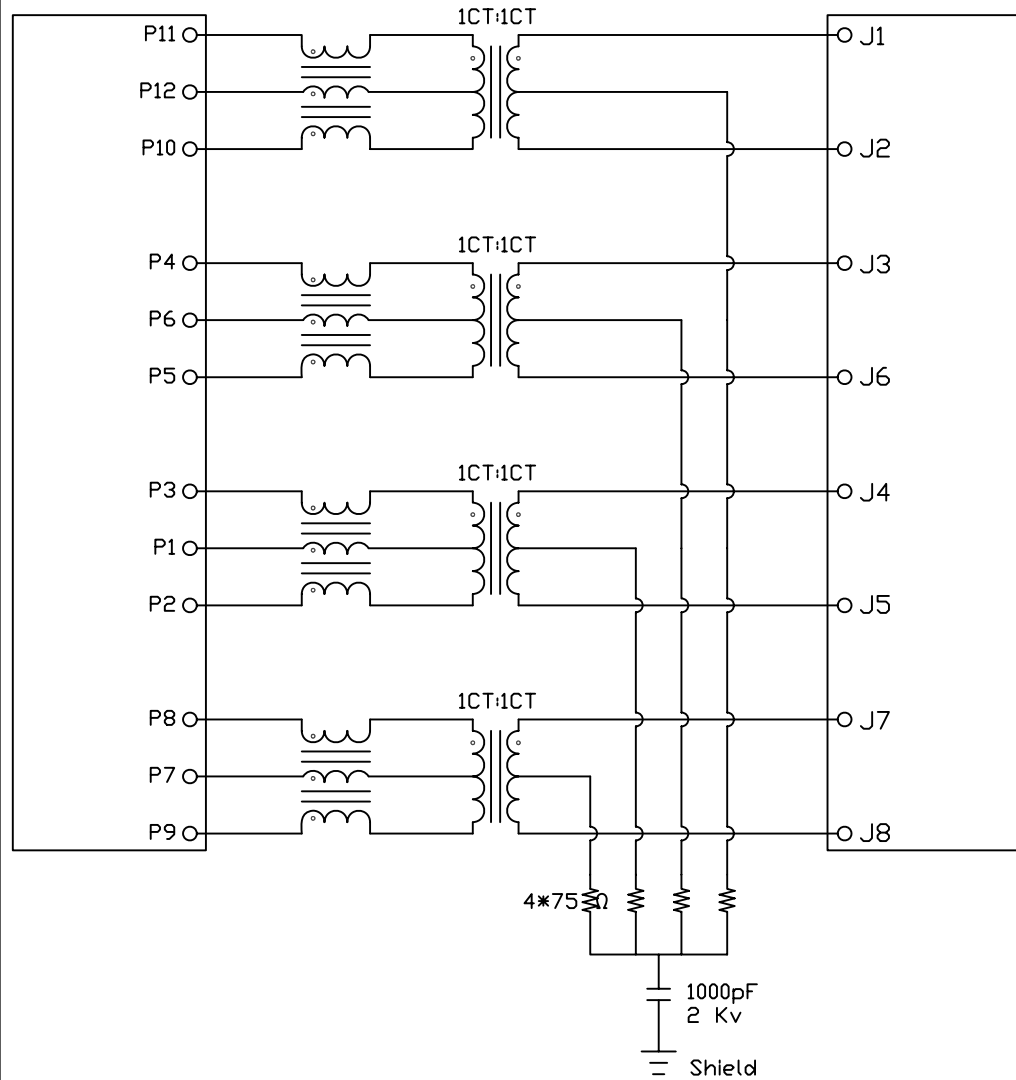



EDAC INC  
TORONTO, ONTARIO  
CANADA

YOUR CONNECTION TO QUALITY & SERVICE

# STANDARD RJ45 MAGNETIC JACKS ELECTRICAL CIRCUIT TYPE

## 39 TYPE: POWER OVER ETHERNET

